



Prince Mohammad Bin Fahad University  
College of Engineering  
Department of Electrical Engineering

Learning Outcome Assessment 3  
Senior Project

**Smart Meter**

Spring 2020

3/3/2020

FERAS ALKHOWAITER 201202578

MAJED ALDOHAILAN 201500975

ABDULLAH ALQARNI 201302190

ABDULLAH ALDAJANI 201502518

ADVISOR:

CHEDLY B. YAHYA, PH.D.

# Outline

- Project Definition
- Project Objectives
- Project Specifications
- Project Architecture
- Background
- Budget Estimate
- Planning
- References

# Project Definition

- ▶ Implementing a smart meter that computes the power consumption in the house and communicates with the controller with a program and the user over the internet.
- ▶ The project will also have the capability to disable some of the loads based on the current electricity price and demand.

# Project Objectives

- ▶ Reduce consumption
- ▶ Reduce costs for consumers
- ▶ Computing the electricity cost for the user in both power consumption and price
- ▶ Providing the costumer and company with a bill
- ▶ Disable unnecessary loads based on power consumption and necessity

# Project Specifications

- ▶ Using Wi-Fi for communication
- ▶ Power of 220 V, 60 Hz
- ▶ Calculating the accumulated cost of consumed energy
- ▶ Providing the electricity bill to the customer and to the company
- ▶ Controlling consumed energy by disabling unnecessary loads

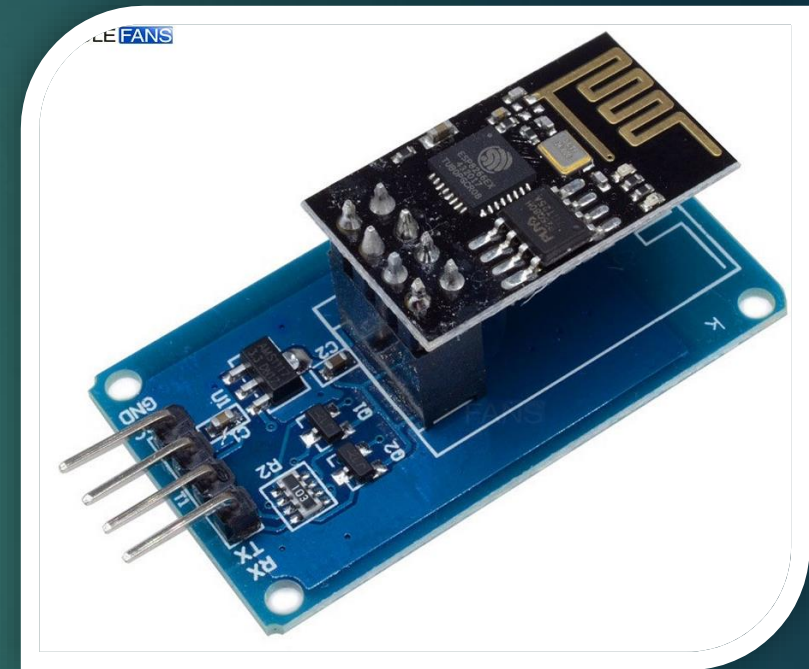

# Project Architecture

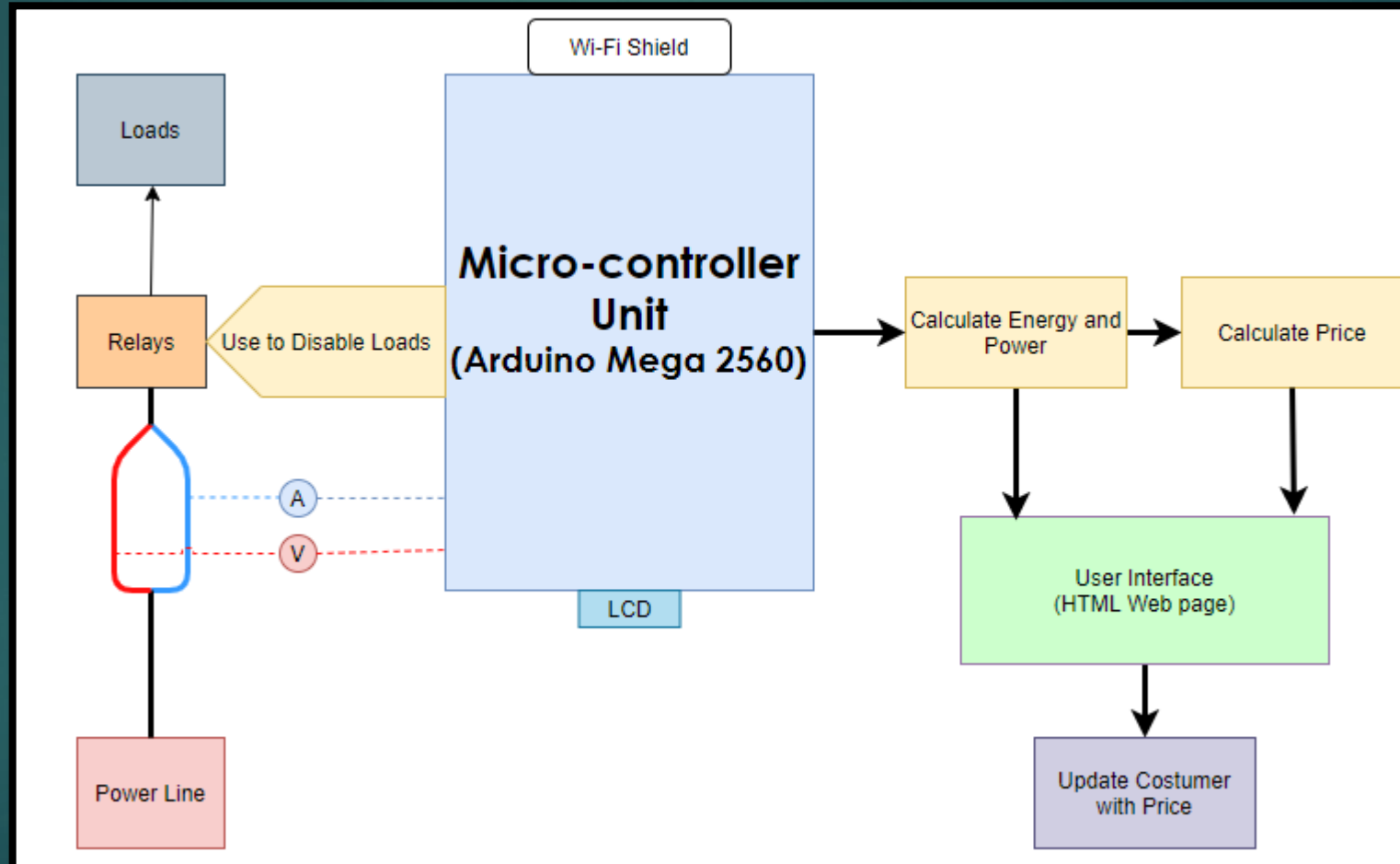

# Background (problem)

- ▶ 289,929,150.000 MWh (2018)

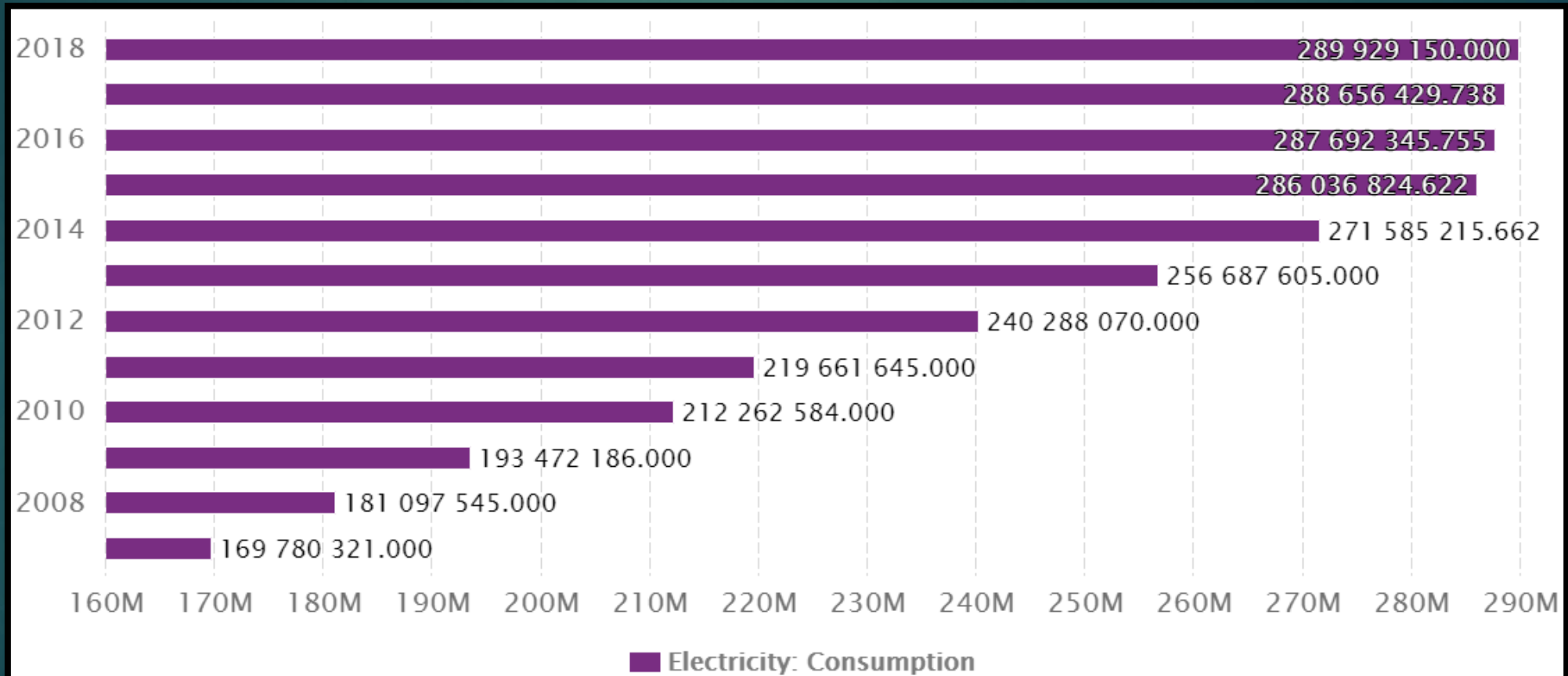

# Background (solution)

- ▶ Customer can adjust their habits to use more during off peak hours to lower electric bills
- ▶ Automated and remote meter reading
- ▶ Compute energy consumption
- ▶ Enabling dynamic pricing

# Subsystem 1 (measuring)

## ► Measuring Voltage

- Constant voltage saves time and effort, its not accurate.
- Voltage reading using voltage transformer with ratio of 220:3 V.
- Connecting between Arduino and transformer is a circuit we found to scale down and offset the AC signal.
- Voltage source created by another voltage divider connected across the Arduino's power supply

# Subsystem 1 (measuring)

## ► Measuring Current

- Adding a bias to the current signal using a voltage source created by voltage divider connected across the Arduino's power supply because Arduino only accept positive values
- Arduino can only deal with voltage so a small resistor was added so that when the secondary current of the transformer pass through it voltage will be produced and measured

# Subsystem 2 (programming)

- ▶ Float ; Take V & I readings
- ▶ Sump :  $V \cdot I$  to find P and add to old values of P
- ▶ Take 1000 Irms and Vrms values and add them together
- ▶ End for loop

```
sump = sump + V*I;  
I_rms = I_rms + I*I;  
V_rms = V_rms + V*V;
```

```
for(samples=0; samples<1000;samples++)
```

```
Energy = P_real*td/1000000.0; // Energy consumed this cycle in Joule  
cumulative_Energy = cumulative_Energy + Energy; // Energy consumed since arduino start Joule  
  
bill = bill + Energy*price;
```

# Subsystem 2 (programming)

- ▶ Calculate P<sub>real</sub> = take abs value of P ( sump /1000)
- ▶ Calculate I<sub>rms</sub> and V<sub>rms</sub> and calculate P<sub>apparent</sub> from them
- ▶ Calculate Power factor from real power and apparent power
- ▶ Calculate energy and bill

```
P_real = abs (sump/samples)* V_ratio* I_ratio;
```

```
I_rms = sqrt(I_rms/samples) * I_ratio;
```

```
V_rms = sqrt(V_rms/samples) * V_ratio;
```

```
P_apparent= I_rms*V_rms;
```

```
PF=P_real/P_apparent;
```

```
Energy = P_real*td/1000000.0; // Energy consumed this cycle in Joule
```

```
cumulative_Energy = cumulative_Energy + Energy; // Energy consumed since arduino start Joule
```

```
bill = bill + Energy*price;
```

# Alternatives

## Voltage

- One alternative is not using voltage reading instead they specify specific voltage level that stays constant

## Current

- Alternative for current measurement is using a current transducer but it requires power supply also its core is not split type to make connection easier

## PF

- Instead of calculating pf through approximation, we ordered a piece of equipment to get actual voltage and hence get actual pf

# Testing

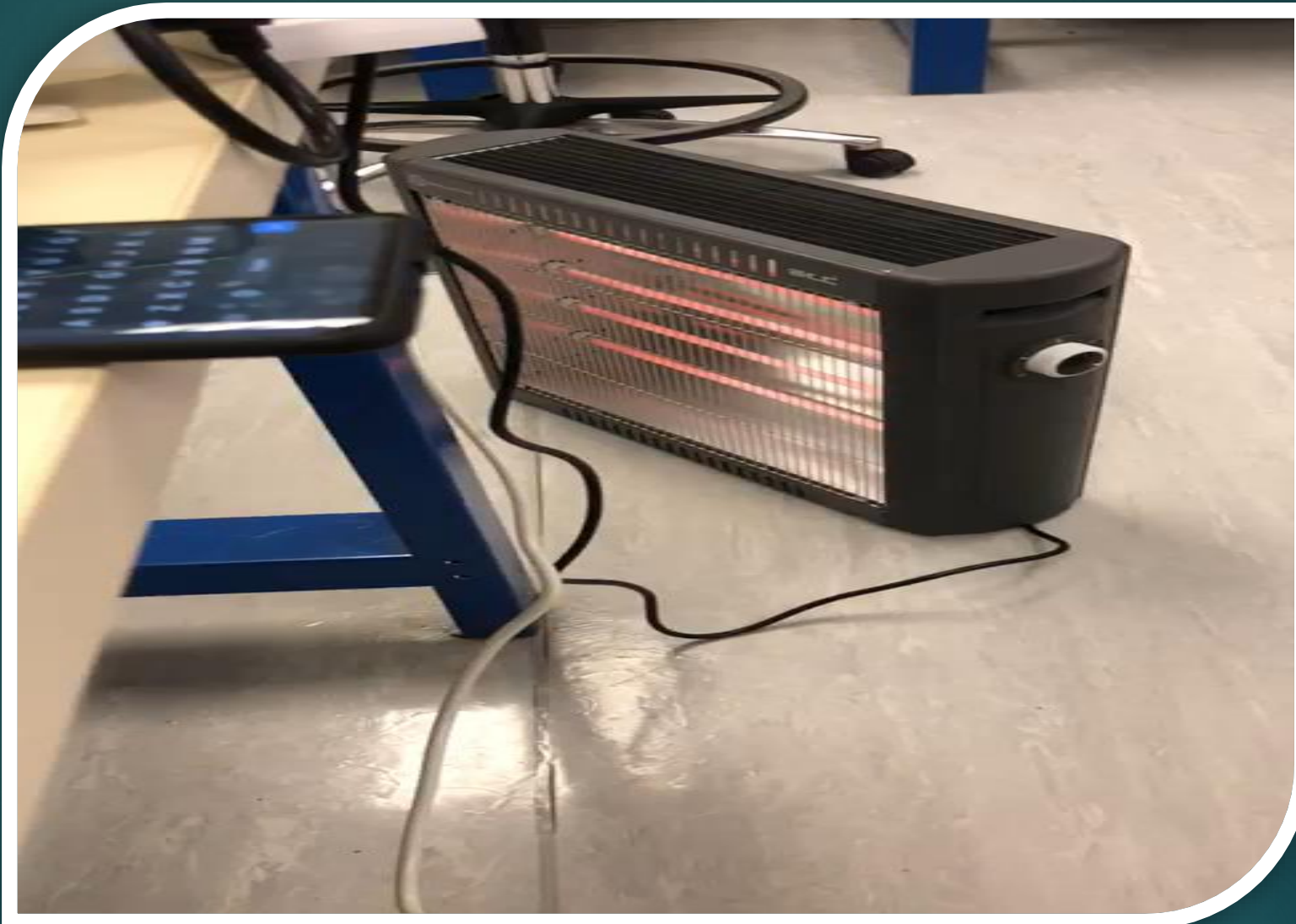

# Testing

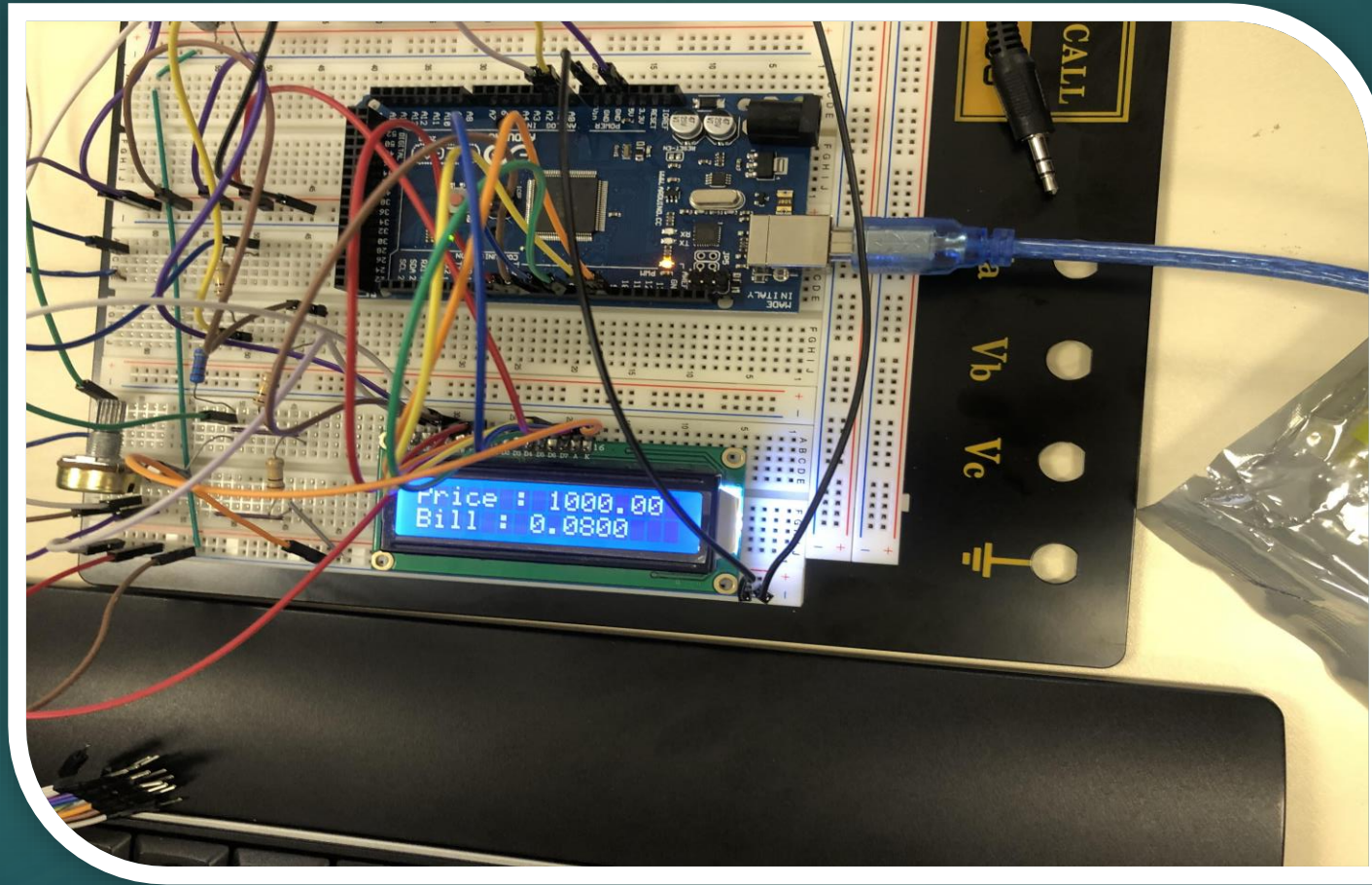

# Testing

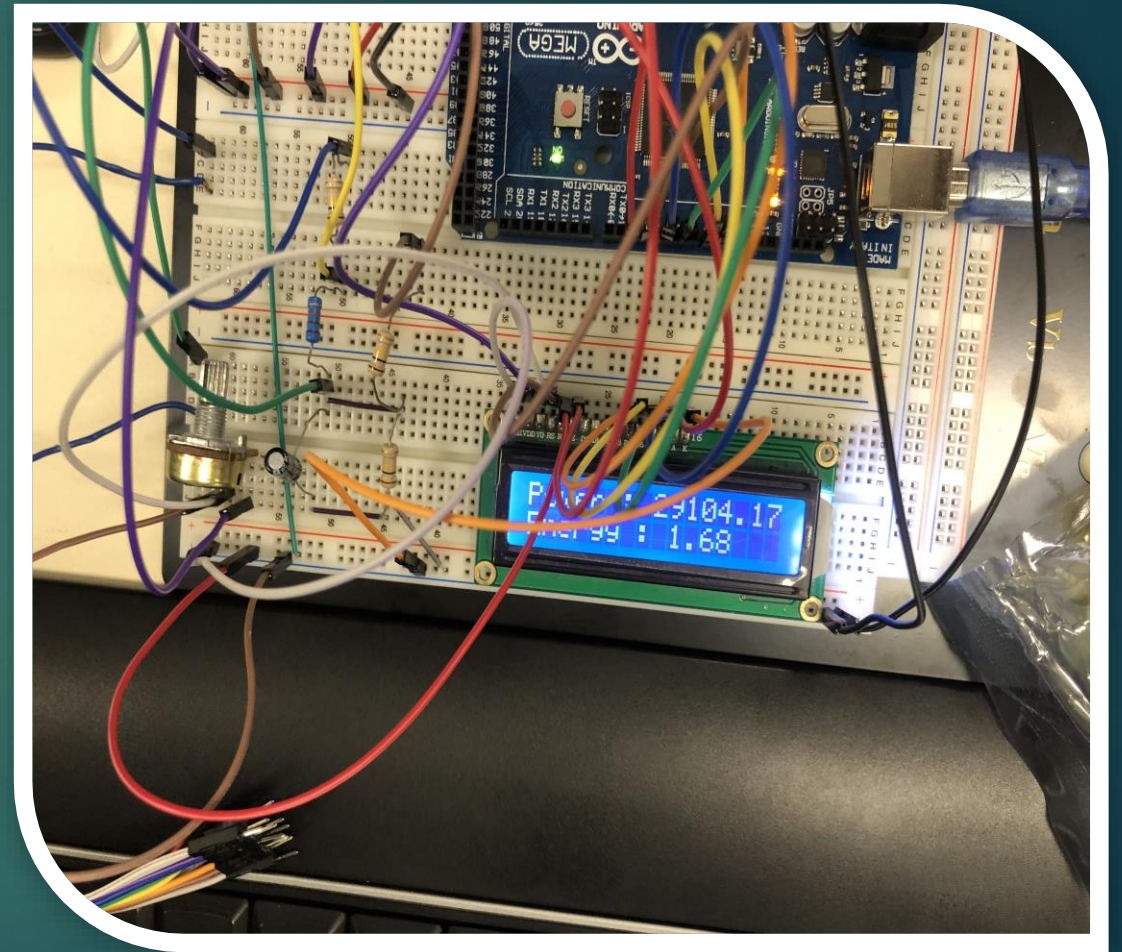
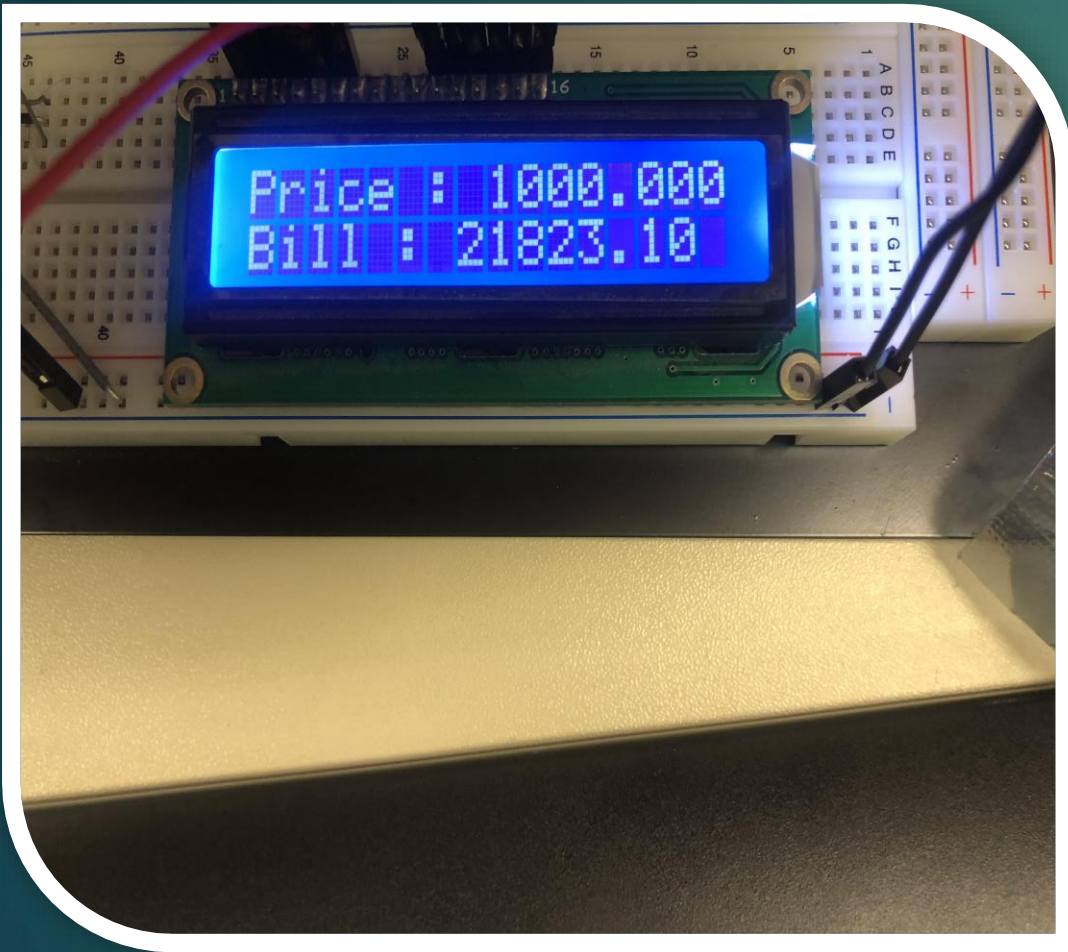

# Visualizing the Data

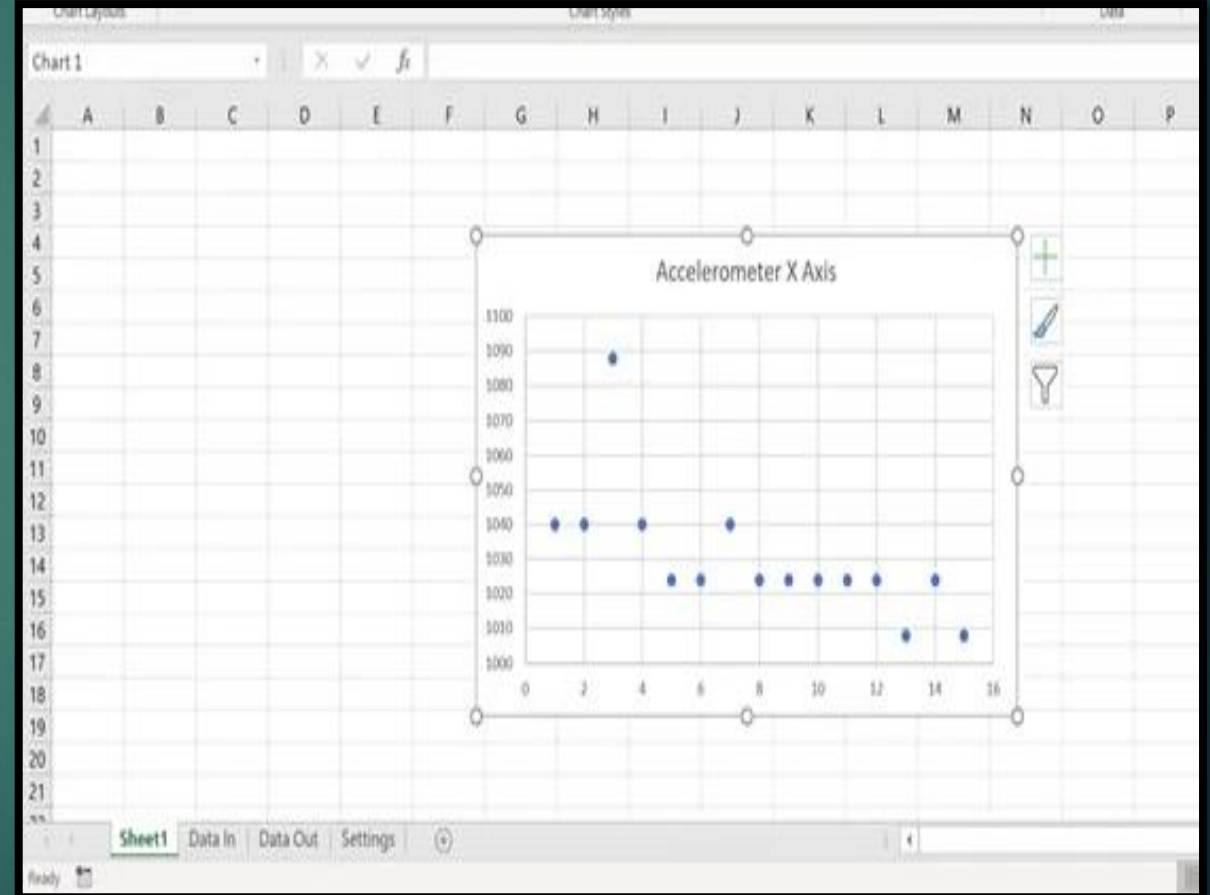
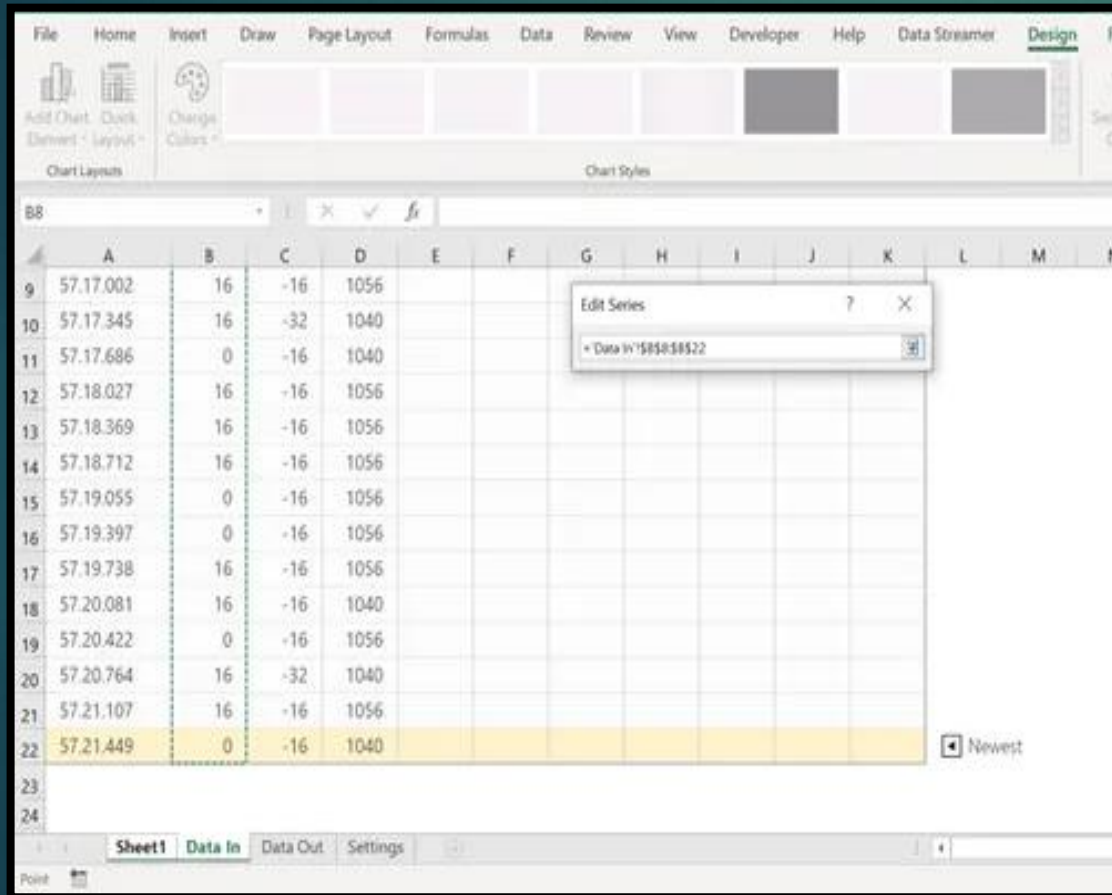

# AC Voltage Sensor Module (zmp101b)



- ▶ To measure the real supply of voltage and therefore, measure actual P.F.

# Challenges



Fall 2019:

- Wall socket doesn't give exactly 220 V and therefore the transformer gives us above 3 V (but still within Arduino range)

Spring 2020:

- The Arduino that we had was ruined
- We had to learn how to make an HTML page
- Some components are delayed in customs

# Progress Report

| Title: Smart Meter   |    | Advisor: Dr. Chedly Yehya |        |   |   |      | Design II (ASSE 3)   |   |   | Spring 2020 |                          |   |        |   |   |    |    |    |    |    |    |
|--|----|---------------------------|--------|---|---|------|--|---|---|-------------|--------------------------|---|--------|---|---|----|----|----|----|----|----|
| Majed Aldohailan 201500975 (MA)  |    |                           |        |   |   |      | Project PLAN & Progress  |   |   |             |                          |   |        |   |   |    |    |    |    |    |    |
| Feras Alkhowaiter 201202578 (F)  |    |                           |        |   |   |      | ProgRpt No. 3  |   |   |             |                          |   |        |   |   |    |    |    |    |    |    |
| Abdullah Aldajani 201502518 (AD)   |    |                           |        |   |   |      | Plan updated (Date): Mar 3, 2020   |   |   |             |                          |   |        |   |   |    |    |    |    |    |    |
| Abdullah alqarni 201302190 (AQ)  |    |                           |        |   |   |      | Instructor: Dr. Sadiq Alhuwaidi  |   |   |             |                          |   |        |   |   |    |    |    |    |    |    |
|  |    |                           |        |   |   |      | Period Highlight:  |   | 4 |             | Plan                     |   | Actual |   |   |    |    |    |    |    |    |
|  |    |                           |        |   |   |      | Actual (beyond plan)   |   |   |             | % Complete (beyond plan) |   |        |   |   |    |    |    |    |    |    |
|  |    |                           |        |   |   |      | Periods (Weeks 1-15)   |   |   |             |                          |   |        |   |   |    |    |    |    |    |    |
|  |    |                           |        |   |   |      | 1  | 2 | 3 | 4           | 5                        | 6 | 7      | 8 | 9 | 10 | 11 | 12 | 13 | 14 | 15 |
| Write a plan   | 1  | 1                         | Ma , F | 3 | 3 | 100% |  |   |   |             |                          |   |        |   |   |    |    |    |    |    |    |
| Get AC voltage sensor module ZMPT101B  | 3  | 1                         | F , AD | 3 |   | 50%  |  |   |   |             |                          |   |        |   |   |    |    |    |    |    |    |
| Design subsystem 1 (measure V,I,P)   | 2  | 1                         | ALL    | 2 | 2 | 100% |  |   |   |             |                          |   |        |   |   |    |    |    |    |    |    |
| Design HTML page and connect to Smart meter  | 3  | 7                         | AD     | 3 |   | 70%  |  |   |   |             |                          |   |        |   |   |    |    |    |    |    |    |
| show consumer data on web page   | 8  | 2                         | F      | 8 |   | 20%  |  |   |   |             |                          |   |        |   |   |    |    |    |    |    |    |
| Acquire wifi module  | 3  | 1                         | MA,AQ  | 3 | 4 | 100% |  |   |   |             |                          |   |        |   |   |    |    |    |    |    |    |
| connect loads  | 6  | 2                         | AD, AQ |   |   | 0%   |  |   |   |             |                          |   |        |   |   |    |    |    |    |    |    |
| Acquire relays   | 6  | 5                         | AQ     |   |   | 70%  |  |   |   |             |                          |   |        |   |   |    |    |    |    |    |    |
| Prepare midterm presentation   | 7  | 3                         | ALL    |   |   | 90%  |  |   |   |             |                          |   |        |   |   |    |    |    |    |    |    |
| Display data to end-user   | 3  | 1                         | F      | 3 | 2 | 50%  |  |   |   |             |                          |   |        |   |   |    |    |    |    |    |    |
| Design subsystem 2 (Calculate bill)  | 1  | 5                         | F , AQ | 3 | 1 | 100% |  |   |   |             |                          |   |        |   |   |    |    |    |    |    |    |
| Test subsystem 2   | 1  | 5                         | F,MA   | 3 | 1 | 80%  |  |   |   |             |                          |   |        |   |   |    |    |    |    |    |    |
| Implement industrail design  | 10 | 1                         | MA, AD |   |   | 20%  |  |   |   |             |                          |   |        |   |   |    |    |    |    |    |    |
| Prepapre final report  | 12 | 2                         | ALL    |   |   | 0%   |  |   |   |             |                          |   |        |   |   |    |    |    |    |    |    |
| Prepapre final presentation  | 12 | 2                         | ALL    |   |   | 0%   |  |   |   |             |                          |   |        |   |   |    |    |    |    |    |    |
| Prepare project demo   | 13 | 3                         | ALL    |   |   | 0%   |  |   |   |             |                          |   |        |   |   |    |    |    |    |    |    |
| Submit Rpt/PPT/Brochure ....   | 14 | 2                         | ALL    |   |   | 0%   |  |   |   |             |                          |   |        |   |   |    |    |    |    |    |    |
| <b>Progress Details:</b>   |    |                           |        |   |   |      | <b>Issues (delay ...):</b>   |   |   |             |                          |   |        |   |   |    |    |    |    |    |    |
| In these two weeks we are still working in the demo and Also we updated our presentation to make it ready before the midterm |    |                           |        |   |   |      | We are waiting for the relays to arrive , there are delayed at the customs |   |   |             |                          |   |        |   |   |    |    |    |    |    |    |
| collecting read from arduino and putting them into excel sheet   |    |                           |        |   |   |      |  |   |   |             |                          |   |        |   |   |    |    |    |    |    |    |

# Budget Estimate

| Components |  | Price   |
|------------|--|---------|
|            | (3) Arduino Mega Microcontroller                   | 310 SR  |
|            | AC Voltage Sensor Module ZMPT101B                  | 100 SR  |
|            | Current Transformer                                | 200 SR  |
|            | Voltage Transformer                                | 60 SR   |
| Relays     | 5V 4 Channel Solid State Relay                     | 40 SR   |
|            | Elegoo 4 Channel dc 5v Relay Module                | 40 SR   |
|            | SSR-40DA 40A Temperature Control Solid State Relay | 40 SR   |
|            | LCD  | 20 SR   |
|            | Wires  | 100 SR  |
|            | Breadboard   | 130 SR  |
| Loads      | Heater   | 100 SR  |
|            | Fan  | 50 SR   |
|            | Motor  | 100 SR  |
|            | Total  | 1320 SR |

# References

- ▶ Barman, B. K., Yadav, S. N., Kumar, S., & Gope, S. (2018). IOT Based Smart Energy Meter for Efficient Energy Utilization in Smart Grid. *2018 2nd International Conference on Power, Energy and Environment: Towards Smart Technology (ICEPE)*. doi: 10.1109/epetsg.2018.8658501
- ▶ <https://ieeexplore.ieee.org/abstract/document/5993967>
- ▶ Barai, G. R., Krishnan, S., & Venkatesh, B. (2015). Smart metering and functionalities of smart meters in smart grid - a review. *2015 IEEE Electrical Power and Energy Conference (EPEC)*. doi: 10.1109/epec.2015.7379940
- ▶ S. Vukmirovic, A. Erdeljan, F. Kulie, S. Lukovic, —A Smart Metering Architecture as a step towards Smart Grid realizationII, 2010 IEEE, pp. 357-362.
- ▶ <https://www.ceicdata.com>