



Prince Mohammad Bin Fahd University

College of Engineering

Department of Mechanical Engineering

Course title: Learning Outcome Asse. IIIMEEN_107

Final Report

Team # (5)

**Project title: Refrigeration System Design and Performance Testing
using Nanofluid as a Secondary Coolant.**

#	Student Name	ID
1	Mohammed Ali Al-Shabebi	201100005
2	Khalid Al-Mutairi	201100921
3	Turki Al Dossary	201103069
4	Abdullah Al-Somali	201102530
5	Abdullah Al Zamel	201101348

Project Advisors:

Advisor: Dr. Esam Jassim

Co advisor: Prof. F. D. Roodi

Abstract

Cooling system is needed in every single house. Cooling devices in refrigeration systems require a high rate of energy consumption to offset the cooling/heating load of a comfort zone. Considerable attention has been recently given to Nano fluids as a secondary coolant in vapor compression refrigeration system that enhances the thermal properties of the refrigerant. The objectives of this project are to design and build a standard refrigeration system that consists of a compressor, condenser and evaporator in the shape of cooling coil. Also, there will be secondary water circuit that has pump, heater and two water tanks 40 liters each, one of them is utilized for the evaporator and the other for water heating process. The two cycles will be combined by inserting the evaporator in the water cooling tank which placed above the heating tank in order to recirculate by the pump. The two cycles will be designed and build to study the impact of inserting Nano fluid on the refrigeration performance and power consumption. Different concentrations (0.1,0.3,0.5g/L) of copper (Cu) nanoparticles has been investigated, copper nanoparticles with a spherical shape and size of 70 nm. The outcome is be very useful in terms of enhancing the refrigeration performance as well as conserving energy consumption. In the different concentrations of copper (Cu) Nano particles the system cooled the medium faster within 5 minutes at 0.5 g/L. On the side of conserving energy the 0.5 g/L reach the maximum of saving energy which is 13.1% of reduction in power consumption.

Acknowledgments

This research supported by the mechanical engineering departments of Prince Mohammed bin Fahd University to come up with achieving the desired results. Great appreciation goes to the mechanical engineering instructors that directly involved by assisting, advising and assessing the work done. Dr. Swalhi the instructor of learning outcomes assessment III, who provided a direct guides to follow, and our advisor Dr. Esam Jassim and the Co. advisor Prof. F. D. Roddi who were involved in the technical wise. Also we would like to thanks Dr. Chedly and Mr. Antonio of electrical department for their partly assistance regarding the helps.

Table of Contents.

Abstract

1. Introduction	
1.1: Project Definition	6
1.2: Project Objectives	8
1.3: Project Specifications	8
1.4: Products Architecture and Components.....	8
1.5: Applications	9
2. Literature Review.....	
2.1: Project background	10
2.2: Previous Work	17
2.3: Comparative Study.....	22
3. System Design.....	
3.1 Design Requirements, Constraints and Specifications	23
3.2 Methodology	25
3.3 Product Subsystems and Components	26
3.4 Apparatus Building & Assembling	28
4. Calculation and System Testing and Analysis	
4.1: Vapor Compression Refrigeration Cycle Calculations	31
4.2: Setting Reference Reading	33
4.3 Adding Nanoparticles	34
4.4: Overall Results	39

5. Project Management.....	
5.1: Project Plan	42
5.2: contribution of team members	44
5.3: Project Execution Monitoring	45
5.4: Challenges and Decisions Making	46
6. Project Analysis.....	
6.1: Life-long Learning	48
6.2: Impacts of Engineering Solutions	49
6.3: Contemporary Issues Addressed	50
7. Conclusion & Future Recommendation	
7.1: Conclusion	50
7.2: Recommendations	51
7.3: Future Work	51
8: References	52
Appendix A (Chapter 4, Experimental Data)	54
Appendix B (Bill of materials)	66
Appendix C (Test & experiments)	67
Appendix D (SolidWork)	72
Appendix E (Operation Manuals)	80

Chapter 1

Introduction

1.1 Project Definition:

This project is about designing and assembling a basic refrigeration system that applies the principles of vapor compression refrigeration cycle in order to use the system in testing the effects of inserting copper (Cu) nanoparticles into the refrigerant gas (R134a), and then to study and investigate changes in specific parameters such as of coefficient of performance and power consumption.

Refrigeration systems are widely used in almost everywhere including (residences, restaurants, airports & more) and although the refrigeration system isn't all the time turned on because once the desired cooled medium reached the required temperature the system's components and devices decreases their power consumption by lowering the amount of work done by them until temperature inside the medium change and then the components starts to runs in full mode again, so the energy consumptions due usage of refrigeration systems is high, it's crucial to look for solutions in order to lower the consumption of energy without effecting the process of the system. "The average household refrigerator consumes 400 kWh to a little less than 600 kWh annually (this applies to modern units that are less than a decade old, older models can consume far more than that). This translates to a cost of (respectively) \$44 USD to \$66 annually at the U.S. national average electricity rate, or \$3.66 to \$5.50 per month. Modern refrigerator power consumption (according to the DOE) ranges from 400 to 600 kWh annually for the

average kitchen unit in the 20 cubic-foot capacity ranges (the 25 cubic-foot models are in the 500 kWh/year range). The larger the refrigerator is, the more power it will consume (compared to models from its time).”[1] So using the copper Cu nanoparticles as an enhancer of the refrigerant R134a due to its thermal high conductivity would help the system to achieve the required amount of work by less time and in high efficiency. More details about nanoparticles technologies and advantages are mentioned in the literature review. The project is divided into five phases, each phase contain several objectives to achieve.

- **First Phase** (Refrigerant system and Nano technology)

Objectives: Studying the refrigerant system components, and Nanoparticles properties.

- **Second phase** (Designing the system and market survey)

Objectives: identifying the required refrigerant system components of the project, market survey and comparing the available options in the market, redesigning the project upon the available parts.

- **Third phase** (Building the system)

Objectives: Building the project upon the designed sketch and testing the system prototype in order to make sure it's fully functional.

- **Fourth phase** (Testing the system with and without Nanoparticles)-

Objectives: Testing the system without adding Nanoparticles, and then testing the system with Nanoparticles.

- **Fifth phase** (Data analysis)

Objectives: analyzing the obtained data and comparing between the results of the refrigerant cycle with and without adding nanoparticles.

1.2 Project Objectives:

The two main objectives of our work are:

- 1- Design and build a basic refrigeration system (vapor compression refrigeration cycle) to use it as a test apparatus.
- 2- Studying the effects of adding copper Cu nanoparticles as a second coolant into the refrigerant.

1.3 Project Specifications:

The apparatus designed to be simple to assemble and disassemble in order to ease the process of transportation of the apparatus, also to be reliable in terms of usage and safety and also ability to change the components of the system in any means to reach the desires of the application. The apparatus runs by electrical power.

1.4 Products Architecture and Components:

As shown in figure 1.1 the system consists of two main sub-systems, first one is the cooling process which is cools the medium or the water inside the tank, the other sub-system is the water cycle system, which is about exchanging of cooled and warmed water of the two tanks in order to keep the cooling process continuous.

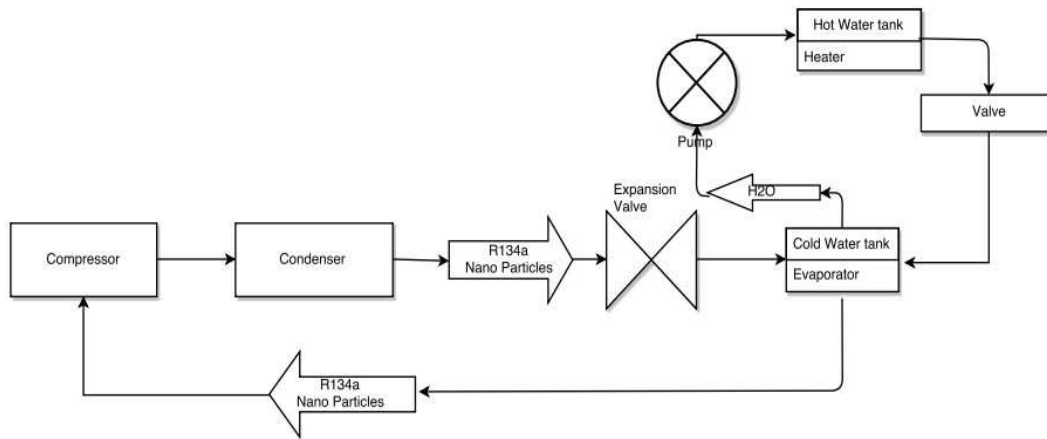

Figure 1.1 block diagram of the system design.

The cooling process sub-system consists of major components, compressor to compress the vapor refrigerant at high pressure and temperature, condenser that receive the outlet refrigerant from the compressor to cool it down to liquid state, expansion valve to pressurize the refrigerant liquid and send it to the tank to cool down the water by heat exchange, finally the refrigerant goes through the evaporator at low pressure to send it to the compressor again. On the other hand the second sub-system which is the water cycle system that uses two tanks one for cold water and the other one for warm water where the heater inside the tank to warm up the water and the movement of water between the two tanks are by using on pump.

1.5 Applications:

Refrigeration systems are widely used in:

- Refrigerators.
- Any applications that's needs cooling process of a medium.

Chapter 2

Literature Review

2.1 Project background:

Refrigeration process is widely used and important for huge amount of applications due to its capabilities of controlling the temperature of desired space, it consists of major components: 1- Compressor. 2- Condenser. 3- Expansion valve. 4-Evaporater. 5- Refrigerant. Figure 2.1. compressor is where the refrigerant compressed with high pressure and temperature and then the refrigerant leaves to the condenser where it liquidize under low pressure and temperature and then goes to the expansion valve before entering the space desired to be cooled down.

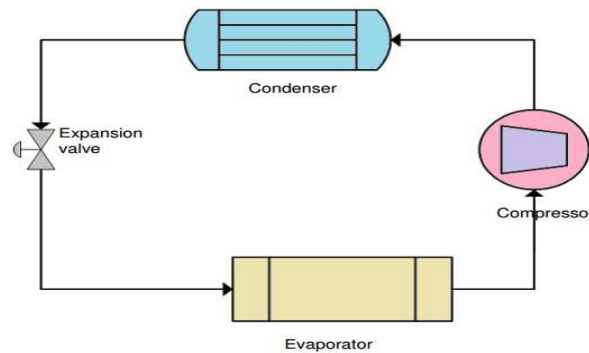

Figure 2.1 Refrigerant cycles components. [1]

Although it comes with high cost, whether from the cycle's parts high power consumption or from the complex of the parts themselves, so that's gained a lot of scientists' attentions of the importance of improving the cycles efficiency in terms of mainly decreases the input power that

runs the refrigerant applications without effecting the qualities of the process. The improvements of our refrigeration cycles started by improving physical parts of the systems such as compressor, condensers, and the fan. On the other hand some studies focuses on the fluid or refrigerant of the cycles by improving its thermal properties and conductivities by introducing new compounds in order to achieve rise in the system efficiency, but that wasn't easy because a lot of used refrigerants or fluids were toxic as well as the damages they cause to the atmosphere also sometimes it causes a huge explosions, an alternative of these toxic fluids were required so a lot of researchers in the industries tried to come up with results. In 1920s a research of Swartz introduced a non-toxic and safe to use refrigerant (chlorofluorocarbon CFC) but because it has chlorine that doesn't consumed in the reaction so researchers after that state chlorine releases from the systems harm the ozone layer, chlorine was eliminated after that and introduced the R134a containing non-toxic and ozone layer friendly elements such as ammonia, carbon & H₂O. R134a refrigerant comprising of two atoms of carbon, two atoms of hydrogen and four atoms of fluorine CF₃CH₂F, with boiling point of -26.2 and most importantly Ozone layer friendly.

While using R134a Freon as the coolant fluid of the refrigerant cycle increases the efficiency by demanding a less input power due to the light weight also the ability to carry decent amount of heat which leads to fine heat exchange and also a good compressible fluid, a demand of more improvement to the refrigerants are required in order to keep reducing the energies needed to run the cycle or to reduce the time required or cycling time of the process by introducing a new way of refrigerants enhancement which is inserting Nano fluids particles with R134a and studying the impact on the cycle performances, for that a new methods to enhance the performances of refrigerants cycles by inserting nanoparticles such as CuO because of the advantages of the properties for example the high thermal of conductivity compared to other

fluids. Basically the process is inserting “the high effective thermal conductivity” nanoparticles with the Freon such as R134a while the advantages of this process due to its high thermal conductivity will reduce the time or frequency of the cycles which will lead to minimize the needed power to cool down the space and that will be increase the efficiency of the cycle. In Table 2.1 some of the thermal and physical properties that mentioned in a scientific article which can be related to our project of studying the effect of the nanoparticles with R134a refrigerant.

Table 2.1 Physical properties of CuO nanoparticle. [3]

Nanoparticles and Conventional refrigerant	Thermal conductivity (W/m·K)	Density (kg/m ³)	Diameter (nm)	Viscosity (Pa·s)
CuO (Copper Oxide)	32.9	6320	40	—
R-134a	0.0139	1202.6	—	0.00019336

In Table 2.2 to Table 2.4 states the thermal and physical properties of copper nanoparticles.

Table 2.2 Specification values in determining Nano-refrigerant properties.[3]

Constant parameter	Value
Refrigerant velocity,	1.2 m/s
Diameter of nanoparticles,	40 nm
Thermal conductivity of copper,	401 W/m·K
Heat transfer coefficient for air, h_{air}	50/m ² ·K
Temperature inlet,	26°C
Temperature outlet,	-10°C

Table 2.3 The thermal properties of copper nanoparticles.[5]

Thermal Properties

Properties	Metric	Imperial
Melting point	1083°C	1981.4°F
Boiling point	2567°C	4652.6°F

Table 2.4 The physical properties of copper nanoparticles. [5]

Physical Properties

Properties	Metric	Imperial
Density	8.94 g/cm ³	0.00032 lb/in ³
Molar mass	63.55 g/mol	

The optimization of this process is mainly to use the new technology of nanoparticles with the high thermal conductivities and other characteristics related to improve the refrigerant systems in order to reduce the input power that runs the system without affecting the quality, also increasing the efficiency of the performance. Some challenges may result in using the nanoparticles such as (the availability of manufacturing the fluids, the corrosion of the pipes, the relatively high cost) but some of these challenges or problems happened because the technology still new and more researches and work needs to be made.

2.1.1 Theory of refrigeration cycle analysis:

Our design follows what is known as vapor compression cycle. *The actual vapor compression cycle* is the most used process in refrigeration. This cycle is obtained by a

refrigerant circulating steadily through a series of components. The cycle begins at the inlet of the evaporator. The refrigerant enters the evaporator as a two-phase liquid-vapor mixture at state 4. in the evaporator the refrigerant changes phase from liquid to vapor as a result of losing heat to the surrounding of the evaporate during the process of state 4 to 1. The refrigerant is then compressed adiabatically from state 1, where it is a vapor mixture, to state 2 where it is a superheated vapor. During this process the temperature of the coolant and the pressure increased from T_L , P_L to T_H , P_H . The refrigerant then leaves the compressor and enters the condenser where it loses heat to the surrounding to become a liquid-vapor at state 3. The refrigerant then is entering a throttling process from state 3 to 4 to enter the evaporator again as a mixture at low pressure and temperature Figure 2.2 & 2.3 illustrate the processes of the cycle.

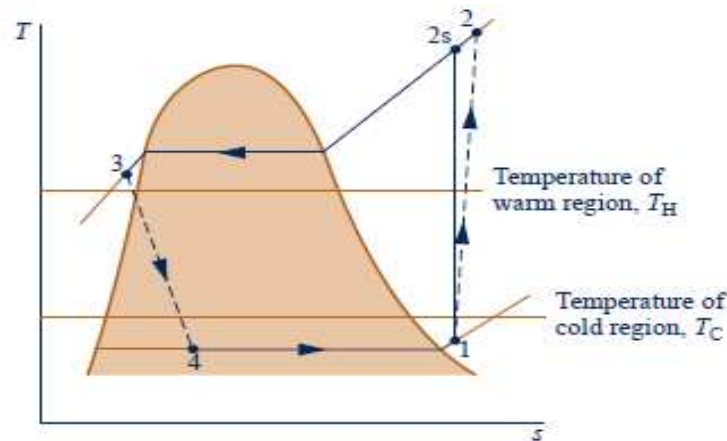

Figure 2.2 T-S diagram of the *actual vapor compression cycle*.

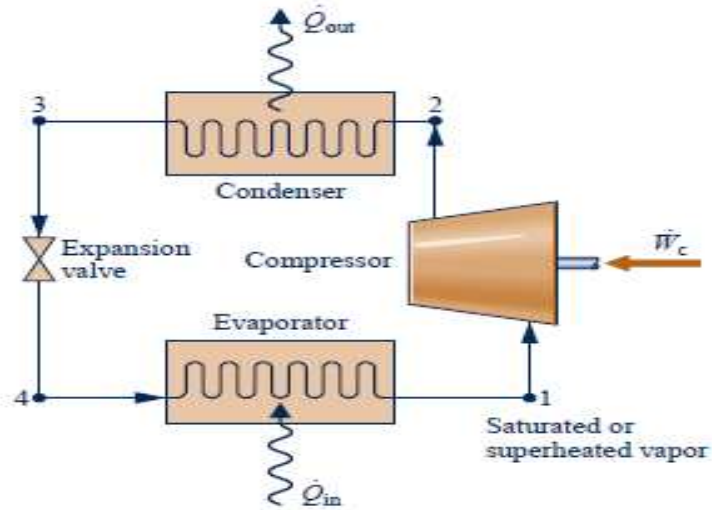

Figure 2.3 components of vapor compression refrigeration cycle.

Understanding our cycle is very important to correctly calculate our cycle's performance. We have 4 different processes in our cycle starting with state 4-1, where the evaporator exchanges heat with the surrounding. The heat is heat gained by the refrigerant can be calculated from the equation 2.1:

$$, \quad \text{eq 2.1}$$

From state 1-2 the compressor is adding work to the system to compress the refrigerant. The work added can be calculated from the equation below:

$$, \quad \text{eq 2.2}$$

From state 2-3 there is a heat rejection process by the condenser at the same pressure. The heat rejected to the surroundings can be calculated from the equation:

$$, \quad \text{eq 2.3}$$

From state 3-4 there is a throttling process where no heat gained or rejected, but the pressure is dropped from high to which give us the equation:

$$h_3 = h_4 \quad , \quad \text{eq 2.4}$$

2.2: Previous Work:

Projects #1: Performance analysis of a domestic refrigerator using CuO – R600a Nano refrigerant as working fluid.[9]

A research a work conducted in Vinayaka Missions University in India, the work was about enhancing the refrigeration cycle in terms of efficiency, COP, energy consumption and cooling load capacity by inserting copper monoxide nanoparticles with the refrigerant R600a. The procedure of their experiment started with testing the system without nanoparticles in order to set up the reference of compression, and after that copper monoxide was added with the refrigerant with different concentrations (g/L) in order to study their individual impacts on the system.

Results:

In Figure .4 the two graphs stated the discharge and suction pressure of the compressor decreases while using CuO in compered to without it, and also it shows that the more concentration(g/L) of CuO leads to decrease in suction pressure.

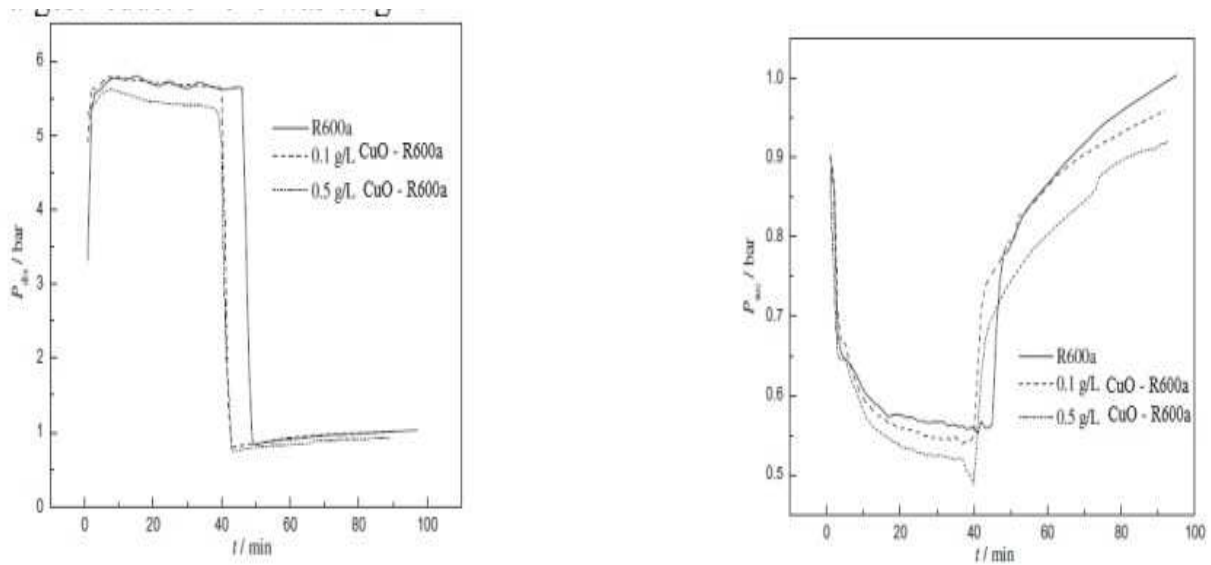

Figure .4 comparison between the compressor under R600a only (left) and with CuO (right). [9]

In Table 2.5 the results of their testing shows that CuO with R600a mixing together as refrigerant increases energy saving percentages and also decreases the consumption of energy. Also worth mentioning, that, the concentration (g/L) is important because the more of concentration leads to lower energy consumption.

Table 2.5 Experimental results. [9]

Proportion(g/L)	Tfd(°c)	Tfz(°c)	Psuc(bar)	Pdis(bar)	Tdom(°c)	Tevp(°c)	Tcond(°c)	TRoom(°c)
0	5.33	-18.13	0.595	5.611	42.14	-24.30	33.87	25.91
0.1	5.40	-18.80	0.583	5.700	45.09	-24.96	34.91	24.99
0.5	5.36	-19.06	0.574	5.463	47.18	-25.14	34.18	25.27

Concentration(g/L)	0	0.1	0.5
Energy Consumption(kWh)	0.9567	0.8435	0.7856
Energy Savings(%)	-	11.83	17.88

Project #2: Comparison of Performance of a Domestic Refrigerator using Al₂O₃

Nanoparticles with PAG Oil and Mineral Oil as Lubricant.[10]

The project's study of interests are about enhancement of refrigeration system by usage of specific nanoparticle, Al₂O₃ nanoparticle was used as an additive to the lubricants oil of the compressor due to its characteristics such as the viscosity. Different types of oil were tested (mineral oil & PAG oil). The nanoparticles were added in different concentrations weight percentages to the both oils, the preparation of mixing Al₂O₃ nanoparticles and the mineral oil were done by usage of ultrasonic waves for some amount of time in order to distribute Al₂O₃ uniformly with the mineral oil.

The main parameters that were focused on in this project are COP, energy consumption and the work done by the compressor.

Results:

The study shows that inserting Al_2O_3 nanoparticles into mineral & PAG oils will scientifically decrease the power consumptions (kW). As in Figure 2.5 it states two separated graphs, each graph represents different weight percentages of Al_2O_3 nanoparticles, left hand side graph is 0.2% and the right hand side is 0.4%. also it states that the best results were the inserting of 0.4% wt. Al_2O_3 nanoparticles into mineral oils using R134a refrigerant, so the percentage of nanoparticles important in order to reduce the power consumption.

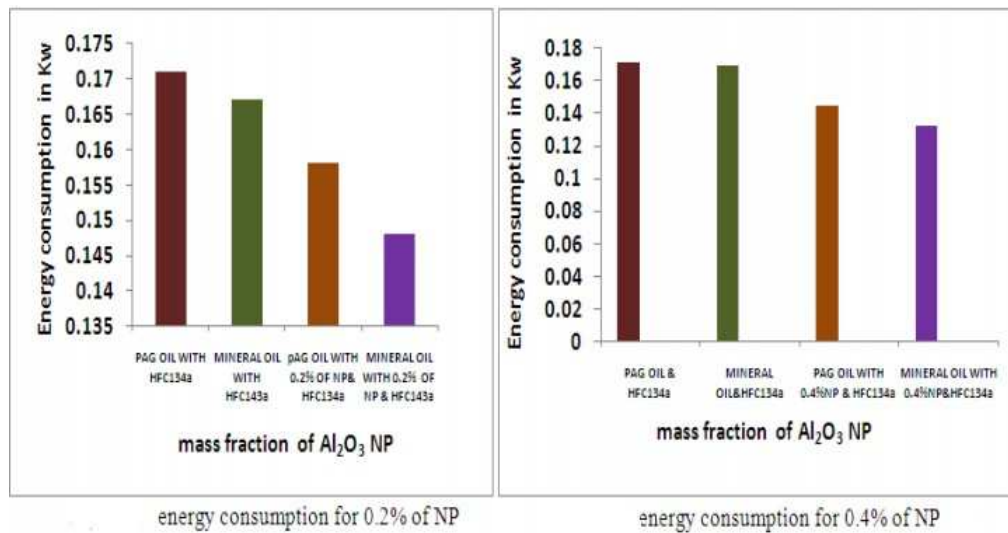

Figure 2.5 Graph of energy consumption (kW) to the four phases of the test, (orange & blue bars shows the addition of Al_2O_3 nanoparticle). [10]

since the study is about reducing the work of the compressor by using Al_2O_3 nanoparticles added to lubricant oils that passes through it, Figure 2.5 shows the graphs of the results on different weight% of nanoparticles, the best results was mineral oil with Al_2O_3 nanoparticles using R134a refrigerant, the work done by the compressor is about 26.5 kJ/Kg which around 5 kJ/Kg less than mineral oil alone.

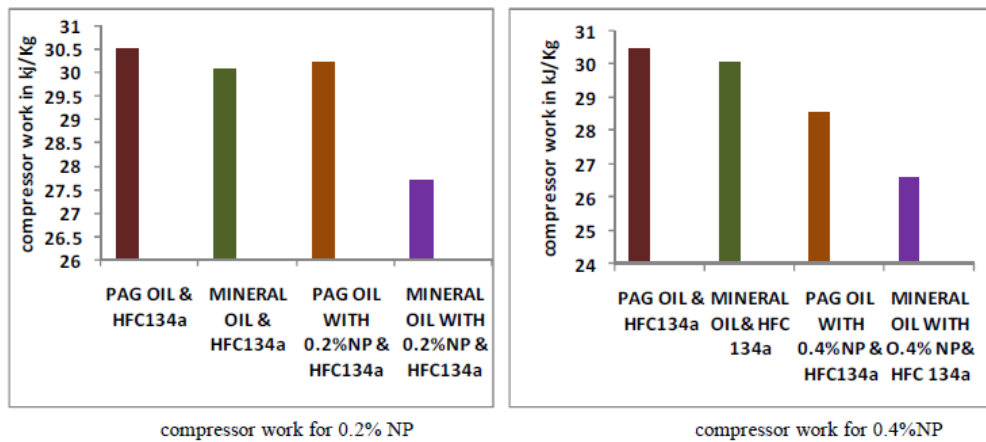

Figure 2.6 Graphs of the work of the compressor, with different weight% of Al_2O_3 nanoparticle. [10]

In Figure 2.6 the graph states that during around 90 days of running the system with nanoparticle keeps it high efficient steady performance without breaking down the components. Which an important parameter and the test show that adding nanoparticles wouldn't harm the system.

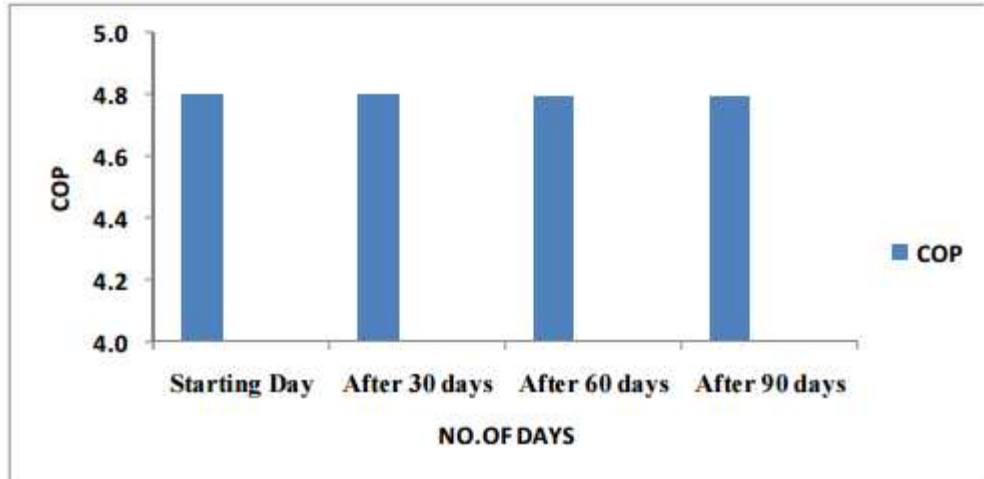

Figure 2.6 life cycle of the system while the usage of nanoparticles. [10]

2.3 Comparative Study:

Comparison between our work and results to the two previous works.

Project #1: Performance analysis of a domestic refrigerator using CuO – R600a Nano refrigerant as working fluid.[9]

Although the objectives of our project and the old one almost the same, the differences are within the type of nanoparticles which will be copper, where the previous project is CuO. Also we are going to use the refrigerant (R134) where they use R600a.

Project #2: Comparison of Performance of a Domestic Refrigerator using Al₂O₃ Nanoparticles with PAG Oil and Mineral Oil as Lubricant.[10]

The main objectives of the project are pretty much the same as ours, in terms of adding the nanoparticles to the system in order to increase the efficiency of the cycle by enhancing the performance of the components, but some main differences as well between the project and ours by using the Al_2O_3 nanoparticle as an enhancement of the oil that contained by the compressor in order to decrease the work done, while our project is about using the Cu nanoparticles and a secondary coolant with the refrigerant.

Chapter 3

System Design

3.1 Design Requirements, Constraints and Specifications

While working on the system design we intended to consider some factors to follow in order to achieve the desired design without invading some standards such as the economic aspects as well as the engineering standards in regards of cooling, also to make the system environmental friendly and safe to use and operate.

Engineering is applying the science of mathematics and physics in economically and ethical matter to find the optimum solution. The system parts had been chosen to reach the most

economically cost for a small scale prototype with higher efficiency as possible, for instant, the two tanks that going to be used in the system are 120 liter each and placed on top of each other in order to save space as well as it will require only one pump to cycle the water between them to achieve the steady-state. Also, the power consumption had been taken under consideration in order to use low power consumption during the testing. The cooling system parts containing compressor and condenser were purchased as a one unit because it's much smaller than the separate parts. Also, the condensing unit is more efficient than the normal but it's more costly. For the engineering standard of the prototype the standers are different from one part to another. In regarding the refrigeration cycle, there are the following standers: for the condensing unit we purchase it from *Danfoss Co.* it follows **ISO / TS 16949** standers. [11] Also the expansion valve was purchased from the same company. However our evaporator is a Saudi manufactured part following SASO standers, as for copper tubes are from *Mueller Co.* for copper tubes and it follows the ASTM **B280** standers. [12]

For the water cycle, we are using plastic tubing and fitting manufactured in Saudi Arabia following SASO standers.

However, for the ethical aspect the environment has rights to be under consideration for designing the prototype by choosing the R134a Freon for the system which is an environment friendly coolant to meet the ethical principles. Another aspect had been taken under consideration which is the movability of the system by reducing the need of permanent connection methods and replaces it with flaring joints. The flaring joints allow the system to be easy to assemble, disassemble and maintenance.

On the other side, choosing the proper Nanoparticles to use in the refrigeration system, the desired Nanoparticles characteristics must match two important parameters, the first parameter is the high thermal conductivity of Nanoparticles, and the second parameter is the hardness. Thermal conductivity is an important parameter because theoretically will enhance the efficiency of the system while inserting it with the R134a Freon, and the hardness of the Nanoparticles is important because taking into consideration the hardness of the copper tubes of the system, if the hardness of the Nanoparticles higher than the copper tubes it will cause erosion which will lead to corrosion damage mechanisms.

3.2 Methodology

In Figure 3.1 the block diagram representation shows the function of the system with the devices and the way of the whole system operate. The approach of the system design started with finding the minimum required tanks capacity and then the rest of the components were chosen in respective to the capacity of the tanks. Since the two sub-systems have tanks in common we made them our reference in term of choosing proper components of the system.

After choosing the proper components and devices, we used SolidWorks software in order to simulate the assembly of the system and using the analyses of the software provide when proper mating and assembling were done. Mainly the design of the system were about matching the

refrigeration components parameters such as cooling & heating capacity in order to reduce time and energy while running the system. While building the steel frame to carry the system were designed and manufactured in a way that can handle the weight of the components and easy to move from one place to another by adding wheels to the frame.

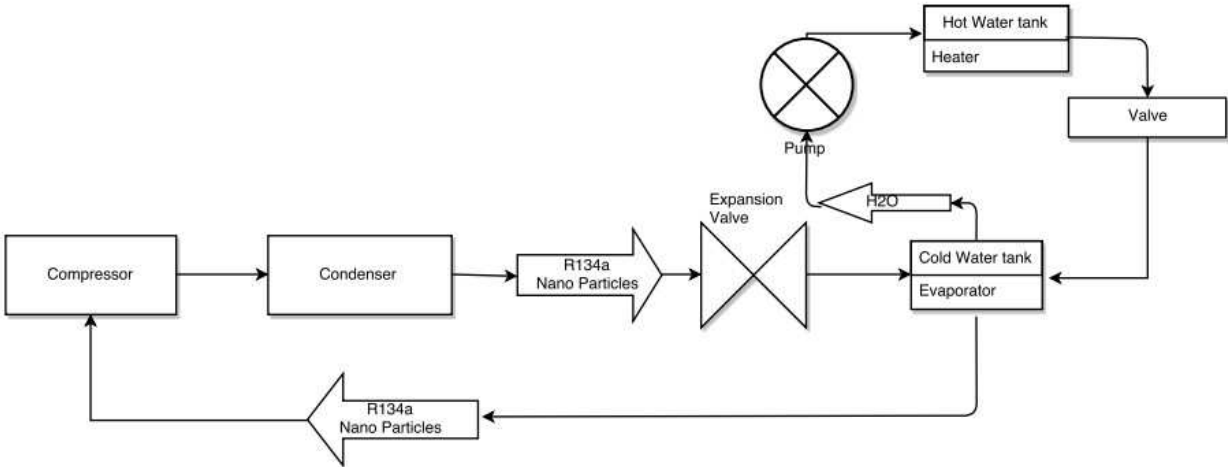

Figure 3.1 Block diagram of the system design.

3.3 Product Subsystems and Components

In (Table 3.1) states the materials and components of the 3 sub-systems been used to build and assemble in the system, 1-16 materials of refrigeration and water systems and 17-24 the ultrasonic transmitter system. Each part and its specifications and quantities used.

Table 3.1: Bill of materials and quantities of the complete system.

#	Bill of Materials	Spefications	Quantities
1-	Compresser	100 watts, 1/3HP, 220V, 60Hz	1
2-	Evaporater	Made of copper tubes & aluminum fins, Copper tube Ø 1/2 inch, Multiple aluminum fins, Suitable for	1
3-	Capillary		1
4-	Pump	Power 80W, Voltage 220V ,Frequency 220V/ 60Hz, Total head 2.5m,Flow rate 2800L/H, Continues	1
5-	Condenser	Horintal condenser	1
6-	Water tanks	120 liter, Made of PVC, Hastwo inlets, one is half inch, and the other one is 1 inch, 2 layers of insulation, 120 liter, Made of PVC. Hastwo inlets one is half inch and the other one is 1 inch 2 layers of insulation.	2
7-	Tempretares gage	For R134a	3
8-	Pressure gage	For R134a	3
9-	Tempretares gage	For water	2
10-	Heating coil	80% nickel, 20% chromium, Kanthal (FeCrAl) wires, Cupronickel (CuNi), 220V	1
11-	Frame fabrication		1
12-	Copper tubes	0.375 in diameter	1
13-	Nanoparticles	Copper (Cu)	50
14-	Refrigerant	R134a, 13 Kg	1
15-	Pluming	1 in, 0.5 in	1 each
16-	Nuts & Nipples	0.25, 0.375	
17-	Transmitter	ultrasonic waves poducer	3
18-	Bread board		1
19-	Transistor	2N2222 A	4
20-	Resistor	1.2 - 1 - 2.2 kΩ	12
21-	Capacitor	100* (10 ⁻¹²)F	1
22-	Battery	12 Volts	2
23-	Timer 555		1
24-	Wires		1 Pack

3.4 Apparatus Building & Assembling



Figure .2: Actual footage of the system.

For assembling the system as our design to be movable by reducing the permanent connection. Starting with welding copper tubes from the evaporator and copper tubes from the compressor to meet with flaring connection by two nuts and one nipple. However for the water cycle connection there were two sides to be connected one of the sides was connected by plastic tubes and a valve while the second side was connected to the pump between the two tanks. All those parts were placed inside a cart.

In order to insert and mix the nanoparticles into the refrigerant R134a is by applying ultrasonic waves using transmitter circuit in order to give the nanoparticles the potential energy to move with R134a. There are many ways to produce the ultrasonic waves but in the economical side there were only one way which is using the ultrasonic transmitter. The transmitter is equipment used to generate and transmit waves. In the first place we had to find the right design of our circuit and modify it to reach the maximum frequency that is needed.

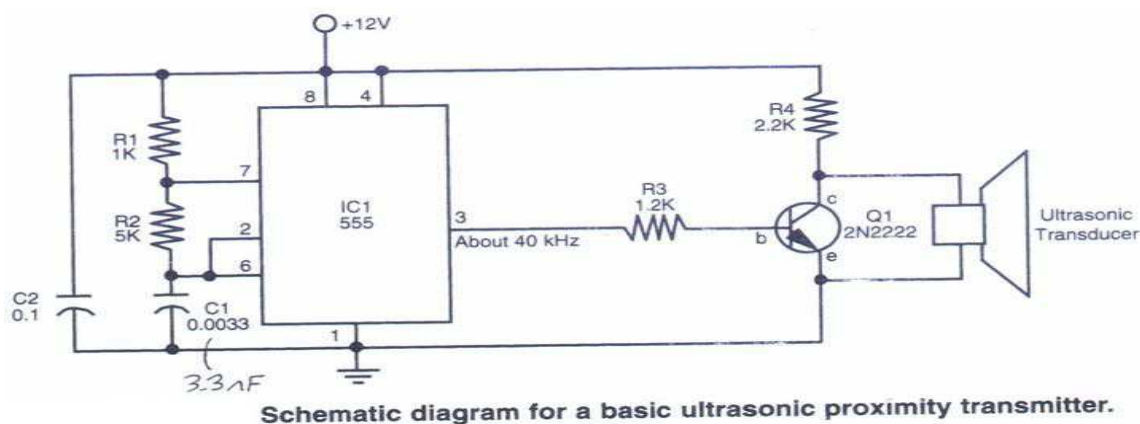

Figure 3.2 schematic diagram of a basic ultrasonic transmitter circuit.

The schematic diagram (Figure 3.2) shows the basic circuit of ultrasonic transmitter with maximum frequency that reaches up to 40 kHz which was not enough. Changing the value of resistor R2 and capacitor C1 until reaching the maximum frequency that the transmitter can produce which was 4.8MHz. by using this equation: $F = \frac{1}{2\pi\sqrt{LC}}$ in the basic form were R2 is 5k Ω and C1 is 0.0033F the frequency is 40 kHz but changing the value into 1K Ω and 100 the maximum will be reached as shown in the equation $F = 4800000\text{Hz}$.

The circuit had been build and the transmitters were placed perpendicular to flow on the part of the system that has the lowest pressure which is the condenser and the evaporator. The perpendicular place of the transmitters on the flow of R134a in the tube didn't allow the nanoparticles of copper to participate in the copper tubes of the condenser and the evaporator.

Chapter 4

Calculation & System Testing and Analysis

4.1 Vapor Compression Refrigeration Cycle Calculations

After designing and performing our experiment, we had the needed data to calculate the performance of our system before inserting the Nano particles. The performance of our original system is a very important aspect to compare it with the performance of the system after inserting the Nano particles.

Given the data from the reference experiment:

$P_L = 120 \text{ kpa}$, $P_H = 1100 \text{ kpa}$, $T_1 = 22^\circ\text{C}$,

We can find the enthalpies for the cycle.

From the properties of R134a table:

@ 120 kpa , $h_1 = 273.5 \text{ kJ/kg}$ & $S_1 = 1.0586 \text{ kJ/kg.K}$

And from the measured temperature 70°C

$h_2 = 302.3 \text{ kJ/kg}$

In state 3 assuming h_3 to be h_f from the saturated vapor table

$$h_3 = 112.565 \text{ kJ/kg} = h_4$$

Calculating the heat gained from state 4-1 from eq.2.1:

$$\text{eq.2.1}$$

From the equation:

$$\text{eq.4.1}$$

The power output tested in the system is 0.506 kW. So our mass flow rate is:

The work done by the compressor can be found from equation 2.2:

$$\text{eq.2.2}$$

We can find the heat rejected to the environment by the condenser to be,

The coefficient of performance is:

4.2 Setting Reference Reading

Before adding a second coolant which is copper nanoparticles, setting a reference reading and measuring the refrigerant temperature and the water temperature will be considered as experiment 1, where the recorded data of experiment 1 is divided into two parts, 1.1 and 1.2, each part in those recorded data will be collected with 0.0 g/L concentration of copper nanoparticles in the system. In recorded data table, A.1 will be done with the two tanks, cold and hot tank and measuring their temperatures, then taking the difference between them until they reach the steady state. In data of 1.2 will be about measuring the temperature of the refrigerant R134a before and after the evaporator.

4.1 Reference reading of difference in cold and hot temperature with respect to time.

Table A.1 in the appendix A demonstrate the first part of the experiment of mixing the cold water and the hot water and measuring it through time, after four minutes we can observe that the T_{hot} and T_{cold} is at steady state. (Figure4.1) explains the ΔT vs. time, through time we can see that ΔT is decreasing from 12.4C to 2.6C in 4.2 minutes.

Figure4.1: graph of water temperature vs. time.

Figure 4.2: Temperature of R134a refrigerant vs. time.

(Table A.2 in the appendixes A) demonstrate the temperature of the refrigerant R134a from two points, first point which is T_{IN} where can be located after the evaporator, and T which is the point where the refrigerant is at the lowest value, before entering the evaporator.

(**Figure 4.2**) shows versus time. From the graph we can see that if the T decreased, T_{IN} is increasing.

4.3 Adding Nano particles

Nano particles will be added to the system after taking consideration of the refrigeration mass. After calculating the mass of the refrigerant, which been found out to be 17.6 grams we added nanoparticles with 3 different mass concentration with respect to refrigeration mass, 0.1g/L, 0.3g/L, 0.5g/L, each mass will be added separately with the refrigerant.

4.2.1: 0.1 g/L of Nano particles experiment 2.1:

Figure 4.3: graph of temperature of water vs. time.

(Table A.3 in the appendixes A) shows the readings after adding 0.1 g/L of Cu nanoparticles to the refrigerant. At the start of the experiment T_{cold} is at 12.5C and the T_{hot} is at 22.6C. And at the end of the experiment T_{cold} increased to 18.5 C and the T_{hot} dropped to 20.1C. (**Figure 4.3**) demonstrate versus time. When the experiment started the water is at 10.1C at 4 minutes the water dropped to 1.6C.

2.2 experiment

Figure 4.4: Temperature of R134a refrigerant with 0.1 g/L Cu nanoparticle vs. time.

(Table A.4 in the appendixes A) shows the readings after adding 3% of Nano particles to the refrigerant. From the table T_{in} is fluctuating between 16C to 17C, also same as the T which is between -1C to 0.2C. (Figure 4.4) demonstrate for the refrigerant versus time. Where the highest temperature is 18.5 C and the lowest is 15.8 C.

4.2.2 0.3g/L of Nano particles experiment 3.1

Figure 4.4: graph of temperature of water vs. time.

(Table A.4 in the appendixes A) shows the readings after adding 5% of Nano particles to the refrigerant. At the start of the experiment T_{cold} is at 12.1C and the T_{hot} is at 21.4C. And at the end of the experiment T_{cold} increased to 17.5C and the T_{hot} dropped to 19.8C. (Figure 4.4) demonstrate versus time. Where the highest temperature is 9.3 C and the lowest is 2.3 C.

Experiment 3.2

Figure 4.5: Temperature of R134a refrigerant with 0.3 g/L Cu nanoparticle vs. time.

(Table A.5 in the appendixes A) shows the readings after adding 5% of Nano particles to the refrigerant. From the table T_{IN} is fluctuating between 22.8C to 22.1C, also same as the T which is between 3C to 0.7C. (Figure 4.5) demonstrate versus time. Where the highest temperature is 22.2C and the lowest is 19.8C.

4.2.3 0.5g/L Nano particles experiment 3.1:

Figure 4.6: Graph of temperature of water vs. time.

(Table A.6) shows the readings after adding 0.5 g/L of copper Cu nanoparticles to the refrigerant. At the start of the experiment T_{cold} is at 12.3C and the T_{hot} is at 22.3C. And at the end of the experiment T_{cold} increased to 16.8 C and the T_{hot} dropped to 19.6C.

(Figure 4.6) demonstrates versus time. Where the highest temperature is 10C and the lowest is 2.6C.

Experiment 3.2

Figure 4.7: Temperature of R134a refrigerant with 0.5 g/L Cu nanoparticle vs. time.

(Table A.7 in the appendixes A) shows the readings after adding 0.5 g/L of Cu nanoparticles to the refrigerant. From the table T_{in} is fluctuating between 22.8C to 22.1C, also same as the T which is between -1.3C to 01.5C.

(Figure 4.7) demonstrate versus time. Where the highest temperature is 23.4 C and the lowest is 20.9C.

4.4 Overall results:

The overall results of our system can be found in two major advantages. The first advantage is the overall improvement in the cooling load of the system. The second advantage is the overall reduction in power consumption.

System cooling:

The figure below shows the compression between four different experiments. The first experiment is without adding the Nano particles and the last three experiments is with adding Nano particles in different concentration to the system. This method enables us to test the exact impact of Nano particles to the cooling properties of the refrigerant. First experiment without adding Nano particles takes approximately 12 min to cool the water from 20°C to 12°C. In the second experiment 0.1 g/L was added as Cu Nano particles. This experiment shows the impact of the particles added in time of cooling. Due to 0.1 g/L added the time for cooling decreased by 2 minutes. In the third experiment 0.3 g/L of Nano particles was added. The reading shows a significant change in the cooling load. The system cooled the water from 20°C to 12°C in 9 minutes, 3 min faster than the reference point. In the final experiment 0.5 g/L was added to the Freon. The difference of the cooling load was very high. To cool the water from 20°C to 12°C in approximately 7 minutes, 5 minutes faster than the first experiment.

Figure 4.8: graph shows the compression between the 4 stages of the experiment.

The graph above showing the cooling of the water in the four experiments in relative to time. The overall performance of Nano particles shows great impact in the efficiency of cooling due to

the thermal properties of the Nano copper and proper mixing of the Nano particles with the Freon. These results also show the optimization of cooling system in relative with time. The other important result in this project is the overall power consumption.

Energy consumption:

One of the fascinating results in our experiments was a reduction in the energy consumption. The chart below shows the power consumption in kW.hr for the different experiments. After adding the Nano particles, the power consumption can change significantly .This drop in consumption can only prove that the cooling of the system is happening more efficiently without any need of maximum output from the compressor which is the most power consuming component in this apparatus.

Figure 4.9: the power consumption in wk.

At first the energy consumption was steadily about 0.506 kW during the first experiment. After adding 0.1g/L of Nano particles in the system the power consumption dropped to 0.484 kW. In the third experiment the power consumption drop again from 0.484 to 0.462 kW. Finally in the last experiment the power consumption reached 0.440 kW. From an original consumption of 0.506 kW in first experiment. The Table 4.8 below shows the reduction in power consumption with the addition of Nano particles.

Table 4.8: the power consumption and power reduction changes of different Cu nanoparticles concentrations.

concentration	0 g/L	0.1g/L	0.3g/L	0.5g/L
Power	0.506	0.484	0.462	0.44

Consumption				
Power Reduction	0%	4.30%	8.70%	13.10%

Chapter 5

Project Management:

5.1 Project Plan:

This project's implementation plan was design to meet with our objectives in the most optimum way possible. In order to achieve the project's goals in scheduled time frame, a detailed implementation plan was needed. Three important aspects were taken into consideration in this plan; project time management, meeting the project design and objectives, over all high efficiency of the project.

The following (Table 5.1) shows the implementation plan regarding time, task, and description.

Table 5.1: Main tasks table, date & description of each task.

Week	Main task	Description
1	Project design stage 1	First design draft. Stating the first bill of material, specification of the parts and requirements.
2	Market survey	Market survey for different specification following the bill of material. Also looking in consideration availability, price, and quality.
2	Project design stage 2	Second design draft using the result of the survey. Come up with alternatives.
3	Virtual design	Designing the apparatus in Solid works.
3	Final design stage	Writing the final bill of material with the needed specifications.
4-5	Purchasing parts	This task involves collecting the budget and purchasing all the required parts.
6	Manufacturing the frame	The frame is the main body of the apparatus where

		all the parts and equipment built on.
7-8	Installing the refrigeration system	Installing all refrigeration system parts together on the frame of the apparatus using the appropriate copper tubes and the best jointing methods for our objectives.
8	Installing the water system	Full installation of the water system on the apparatus using plastic piping and fitting.
8	Completing apparatus installation	Completing the installation stage and installing pressure and temperature gages to the systems.
10	Testing the integrity of the apparatus	Testing the apparatus for any leakage or any installation defects by filling the tanks with water and checking the cooling system of any Freon leakage.
11	Starting the data collection	First full system test and gathering reference data for our cooling system by testing with only R134a without any Nano particles.
11	Collecting data stage #1	Collecting data for our tests and analyzing for any errors
12	Inserting Nanoparticles	Inserting Nanoparticles in our system in different ratios.
12	Collecting data stage #2	Collecting data after inserting nanoparticle in the cooling system.
13-14	Data analysis	Comparing the two stages of the data collections. Studying the effect of inserting the nanoparticles in system In the order of the ratio impact to the overall performance. Also the integrity of the system in the long run period.
15	Finalizing the final report	Finishing the calculation and finalizing the thesis.

5.2 contributions of team members:

In Table 5.2 shows the main work and project objectives and tasks and how much each group member contribute individually in order to achieve the main objectives of the group work.

Table 5.2 states the percentage of work done by each member in respect to the task assigned.

Task	Mohammed AlShabebi	Turki AIDossary	Khalid Al Mutiri	Abdullah AlZamil	Abdullah AlSomali
Design	100%	100%	100%	100%	100%
Market Survey & Parts purchase	100%	100%	70%	70%	100%
Building the system	100%	100%	100%	70%	70%
Oral presentation & complete literature review & first progress report	70%	70%	70%	100%	70%
Testing	100%	100%	100%	100%	100%
2nd progress report	100%	100%	100%	100%	100%

Finalize thesis writing, Poster, Project PowerPoint and a summary document for Conference publication	100%	100%	100%	100%	100%
---	------	------	------	------	------

5.3 Project Execution Monitoring:

Meetings:

We met every Sunday Tuesday and Thursday and we divide the tasks between each other. We met with our advisor every Tuesday at 4 clock in his office.

Testing:

The timing for the testing was a challenge due to other requirements we had to solve this problem by schedule it in the long breaks and weekends. Also, we had planned to take different readings for every stage in order to get better reading as we could.

5.4 Challenges and Decisions Making:

Leakage:

The first leakage we faced was in the refrigeration system were one of the copper tubes had been broken in critical place in the condenser. The major difficulty was in the ability to weld in the condenser. To solve this issue we had to melt a little part that surrounding the tube in order to weld the tube and solve the leakage.

In the other cycle which is the water cycle the connection between the two tanks were leaking. A simple solution was replacing the connection tubes with a new bigger diameter. Also, changing the pump to a smaller size pump to be easy to control the leakage and stop it.

Evaporator:

Our main issue was to find an evaporator in the market, it was hard to find evaporator fit with condenser unit size, we search in the markets and factories until we found a local factory have the same size that we need it.

Temperature gauges:

The required temperature gauge for the system was expensive and it cost for one gauge 400sr and we want 3 gauges, and it does not follow our specifications in terms

Of measuring the super-heated temperature. The solution was to use a thermocouple and place the sensor in the cooper tube and cover it cold welding.

Nanoparticles:

Copper nanoparticles were purchased from USA because of unviability of the nanoparticles locally in KSA, so we did an online market surveys to make sure that it follows the standards specifications and the reliability of nanoparticles factory.

Ultrasonic circuit:

Ultrasonic waves were needed in order to make sure copper nanoparticles mixed properly with the refrigerant R134a, so we did used helps from the electrical department at PMU to do the ultrasonic transmitter circuit.

Chapter 6

Project Analysis:

6.1: Life-long Learning:

- Skills: Leadership, Team management and team work, troubleshooting, working and achieving under pressure, and sticking as much as we can to the plans.
- New devices: compressor, condenser, ultrasonic transmitter, welding tools, permanents and temporary joining.
- New technologies: nanoparticles, ultrasonic waves.
- Tools used to find information: scientific textbooks (Manufacturing in Design & methods, Thermodynamics I & II, Mechanical engineering design), online websites (scientific journals and researches such as ASME, nanoparticles associations & thermodynamics standards).
- Software used: (Solidworks, Excel, Gent charts).

6.2 Impacts of Engineering Solutions:

This study provides effective solutions and enhancement to the performance of vapor compression cycles in terms of saving energy by minimizing the time of reaching the desired output, which will lead to also saving a huge amount of energy sources and that's will help the

environments, as well as economical wise in terms of spending on the process. Also applying a new technology (nanoparticles) in positive and proper ways in order to open up the chances and the opportunities this new technology provides for the future.

6.3 Contemporary Issues Addressed:

KSA consume high amount of energy in refrigeration systems and applications, this main issue is a concern to people who're involved, and so by addressing our studies and results we are trying to contribute in order to help the society in terms of saving energies and power consumption. And also to follow the new ideas of 2030 where we looking forward to use the energy efficiently in refrigeration processes.

Chapter 7

Conclusion & Recommendations:

7.1: Conclusion:

Our project is refrigeration system design and testing using Nano-fluid as a secondary coolant. This project started by designing an apparatus suitable for testing Nano particles in the refrigeration system. This project was successful to reach the objectives of this study. Our objectives were to enhance the cooling properties in the system, also to reduce the overall consumption of energy. Our objectives were based to relative work done in this field. The literature shows that the using of high thermal properties Nano particles in the refrigerant can enhance the efficiency of the cooling system and optimizing the power consumption. The Nano particles used in this project is Copper Nano particles due to its high thermal connectivity. Our result can be shown in two main enhancements, overall cooling efficiency and reduction in power consumption.

The time of cooling can be reduced by adding Nano particles. The time of cooling can vary with the concentration of Nano particles added to the system. We reached the peak of cooling at 0.5g/L to reduce the time needed to cool the water media from 12 min to 7 min. the second major finding in this project is that the reduction in power consumptions can vary with the concentration of Nano-copper. Our experiments show the higher the concentration, the higher the reduction in power. At our peak point the power reduction reached 13.1 % of the original consumption. This project shows a promising solution in refrigeration cycle. The experimental results show a great enhancement using this approach.

7.2: Recommendations:

Due to the limited time for this course we couldn't have a chance to investigate the different types of nanoparticles. Our recommendation for the further investigation in Nano particles in the refrigeration cycle is to use another type of material such as monoxide copper, trioxide aluminum. Also, for better results in the future we recommend to use the Nano lubricant oil for the compressor. Regarding the system our recommendation is to reduce the size of the tanks and increase the cooling load by increasing the tone of refrigerant.

7.3 Future works:

Study the life cycle of the system with Cu nanoparticles injected, and how that will affect the system in the long term.

Studying the effects of changing the types of nanoparticles injected to the systems in terms of their thermal conductivities.

8. References:

- 1- Nicholas brown. "how much power are your appliances actually consuming?" *kompulsa*. Kompulsa, 2015. Web. 20 dec. 2016.
- 2- 95, Page : 1 Of. "refrigeration systems (process engineering equipment design guideline)." *refrigeration systems (process engineering equipment design guideline)* (n.d.): n. pag. *klm*. web.
- 3- The tecumseh hermetic compressor service handbook.
- 4- "Copper oxide nanoparticles for advanced refrigerant thermophysical properties: mathematical modeling." *copper oxide nanoparticles for advanced refrigerant thermophysical properties: mathematical modeling*. Hindawi, n.d. Web. 02 nov. 2016.
- 5- Journal Of Nanoparticles, Volume 2014 (2014), Article Id 890751, 5 Pages
- 6- Azonano, written by. "copper (cu) nanoparticles - properties, applications." *azonano.com*. N.p., 11 july 2013. Web. 01 nov. 2016
- 7- Ale, organisation intergouvernement, and pour le développement du froin. "a brief history of refrigeration." *177, boulevard malesherbes, 75017 paris, france - tél. 33-(0)1 42 27 32 35 - fax 33-(0)1 47 63 17 98 - e-mail : iifiir@iifiir.org - web : www.iifiir.org a brief history of refrigeration*(n.d.): n. Pag. *Institut international du froid*. Web.
- 8- By 1895, compression/evaporation-cycle refrigeration was being used in most of the industrialized world. "a brief history of refrigerant." *mobile air conditioning society macs worldwide*. N.p., 20 sept. 2013. Web. 01 nov. 2016.
- 9- "History of global warming and climatology." *ebsco*. N.p., n.d. Web
- 10- A.senthilkumara, r.praveenb. "<http://journal.ru/wp-content/uploads/2016/08/d-2016-154.pdf>." *journal of chemical and pharmaceutical sciences* (2015): n. Pag. Web.

11- R k adyanshee pattanayak¹ , prasheet mishra² , amitava sarkar³. "comparison of performance of a domestic refrigerator using al₂o₃ nanoparticles with pag oil and mineral oil as lubricant." *international journal of application or innovation in engineering & management (ijaiem)* (2016): n. Pag. Print.

12- Danfoss iso / ts 16949 - quality management

<http://heating.danfoss.com/contact/about-us/quality/ts16949/#/> .

13-Mueller Streamline Co. Copper tube Standers.

14- <https://surpluscityliquidators.com/products/13-hp-air-cooled-hightemp-indoor-refrigeration-condensing-unit-10011560501-r134a.html>

15- <https://surpluscityliquidators.com/products/14-hp-air-cooled-lowtemp-indoor-refrigeration-condensing-unit-10011560501-r404a.html>

Appendix A

(Chapter 4, Experimental Data)

Table A.1 (Reference reading of difference in cold and hot temperature with respect to time).

Time (Min)	T_{cold} (C)	T_{hot} (C)	ΔT
0	11	23.4	12.4
0.2	11.1	21.9	10.8
0.4	11.1	20.7	9.6
1	11.8	20.8	9
1.2	11.8	20.5	8.7
1.4	11.3	20.5	9.2
2	11.2	20.2	9
2.2	11.1	19.5	8.4
2.4	11.1	18.6	7.5
3	11.3	19.3	8
3.2	16.7	19.1	2.4
3.4	16.6	19.1	2.5
4	16.6	19.3	2.7
4.2	16.9	19.5	2.6

Table A.2 (Reference Reading):

Time (Min)	T_{IN} (C)	T (C)	ΔT
0.2	23.5	1.7	21.8
0.4	23.8	1.2	22.6
1	23.8	0.5	23.3
1.2	24.2	0	24.2
1.4	24.3	0	24.3
2	23.6	2.2	21.4
2.2	23.5	3.4	20.1
2.4	23.9	1	22.9
3	24.1	0	24.1
3.2	24.1	0	24.1
3.4	23.6	3.4	20.2
4	23.6	0.5	23.1
4.2	23.8	0	23.8
4.4	24.1	-2	26.1
5	24.1	-1.8	25.9
5.2	23.8	1.7	22.1
5.4	23.9	3.2	20.7
6	23.9	1.5	22.4
6.2	23.9	0.2	23.7
6.4	23.6	0	23.6
7	23.9	2.5	21.4
7.2	23.6	2.7	20.9
7.4	23.8	1	22.8
8	23.9	0	23.9
8.2	23.8	0	23.8
8.4	23.5	1.7	21.8
9	23.6	2.5	21.1
9.2	23.7	0.5	23.2
9.4	23.8	0	23.8
10	23.6	1.2	22.4
10.2	23.3	1.7	21.6
10.4	23.4	1.5	21.9
11	23.6	0.7	22.9
11.2	23.6	0.2	23.4
11.4	23.6	1	22.6
12	23.4	1.5	21.9
12.2	23.7	0.2	23.5
12.4	32.8	-1	33.8
13	23.6	0	23.6
13.2	23	1.5	21.5
13.4	23.3	1	22.3

14	23.1	0.2	22.9
----	------	-----	------

Table A.3 (0.1 g/L of Nano particles experiment 2.1)

Time (Min)	T_{cold} (C)	T_{hot} (C)	ΔT_{water}
0	12.5	22.6	10.1
0.2	12.3	20.9	8.6
0.4	12.8	20.3	7.5
1	14.4	20.3	5.9
1.2	17.8	20.2	2.4
1.4	17.9	20.2	2.3
2	18	20.2	2.2
2.2	18.3	20.3	2
2.4	18.5	20.1	1.6

Table A.4 (experiment 2.2)

Time (Min)	T_{IN} (C)	T (C)	ΔT
0.2	16	-1	17

0.4	17	0	17
1	17	0	17
1.2	17	0	17
1.4	17	-1	18
2	16	-1	17
2.2	16	0	16
2.4	16	0	16
3	16	0	16
3.2	16	-1	17
3.4	16	0	16
4	16	0	16
4.2	16	0	16
4.4	16	0	16
5	16	0.2	15.8
5.2	17	0.2	16.8
5.4	17	0	17
6	17	-1.3	18.3
6.2	17	-1.5	18.5
6.4	17	-1.3	18.3
7	17	-1	18
7.2	17	0	17
7.4	17	0	17
8	17	0	17
8.2	17	0	17
8.4	17	0	17
9	17	0	17
9.2	17	0	17

Table A.4 (0.3g/L of Nano particles experiment 3.1)

Time (Min)	T_{cold} (C)	T_{hot} (C)	ΔT_{water}
0	12.1	21.4	9.3
0.2	11.8	20.1	8.3
0.4	14.7	20.6	5.9
1	16.7	20.1	3.4
1.2	16.9	19.8	2.9
1.4	17.3	19.6	2.3
2	17.2	19.6	2.4
2.2	16.8	19.8	3
2.4	17.2	20	2.8
3	17.5	19.8	2.3

Table A.5 (Experiment 3.2)

Time (Min)	T_{IN} (C)	T (C)	ΔT
0.2	22.8	3	19.8
0.4	22.8	2.2	20.6
1	22.8	1.5	21.3
1.2	22.9	0.7	22.2
1.4	22.6	1	21.6
2	22.6	0.7	21.9
2.2	22.9	0.7	22.2
2.4	22.7	0.7	22
3	22.6	1	21.6
3.2	22.9	1.2	21.7
3.4	22.8	1.2	21.6
4	22.6	1.5	21.1
4.2	22.6	1.5	21.1
4.4	22.6	1.2	21.4
5	22.5	1	21.5
5.2	22.4	0.7	21.7
5.4	22.4	0.7	21.7
6	22.3	1	21.3
6.2	22.2	1	21.2
6.4	22.1	1	21.1
7	22.4	1.5	20.9
7.2	22.4	1.5	20.9
7.4	22.4	1.2	21.2
8	22.3	1.2	21.1
8.2	22.3	1.2	21.1
8.4	22.2	1	21.2
9	22.1	0.7	21.4

Table A.6 (0.5g/L Nano particles experiment 3.1)

Time (Min)	T_{cold} (C)	T_{hot} (C)	ΔT_{water}
0	10.7	22.3	11.6
0.2	10.9	20.7	9.8
0.4	15.4	20.6	5.2
1	15.7	20.1	4.4
1.2	16	20.2	4.2
1.4	15.4	19.8	4.4
2	15.2	19.6	4.4
0	10.7	22.3	11.6
0.2	10.9	20.7	9.8
0.4	15.4	20.6	5.2

Table 4.7(Experiment 3.2)

Time (Min)	T_{IN} (C)	T (C)	ΔT
0.2	22.6	1.2	21.4
0.4	22.6	0	22.6
1	22.6	0	22.6
1.2	22.9	0.7	22.2
1.4	22.8	1	21.8
2	22.6	1.5	21.1
2.2	22.4	1.5	20.9
2.4	22.4	0	22.4
3	22.6	0	22.6
3.2	22.4	0.7	21.7
3.4	22.4	1.2	21.2
4	22.9	0.7	22.2
4.2	22.7	1.2	21.5
4.4	22.9	0.7	22.2
5	22.9	1.2	21.7
5.2	22.9	0.7	22.2
5.4	22.8	0.7	22.1
6	22.4	1	21.4
6.2	22.1	0	22.1
6.4	22.1	0.7	21.4

7	22.3	0.2	22.1
7.2	22.4	0.2	22.2
7.4	22.1	-1.3	23.4
8	22.1	-1	23.1
8.2	22.4	0.2	22.2
8.4	22.4	0	22.4

Appendix B

Bill of materials

#	Bill of Materials	Spesfections	Quantities	Price (SAR)
1-	Compressor	100 watts, 1/3 HP, 220V, 60Hz	1	900
2-	Evaporater	Made of copper tubes & aluminum fins, Copper tube Ø 1/2 inch, Multiple aluminum fins, Suitable for	1	200
3-	Capillary		1	15
4-	Pump	Power 80W, Voltage 220V ,Frequency 220V/60Hz, Total head 2.5m,Flow rate 2800L/H, Continues	1	140
5-	Condenser	Horintal condenser	1	0
6-	Water tanks	120 liter, Made of PVC, Has two inlets, one is half inch, and the other one is 1 inch, 2 layers of insulation, 120 liter, Made of PVC. Has two inlets one is half inch and the other one is 1 inch 2 layers of insulation.	2	400
7-	Tempretares gage	For R134a	3	180
8-	Pressure gage	For R134a	3	120
9-	Tempretares gage	For water	2	60 each
10-	Heating coil	80% nickel, 20% chromium, Kanthal (FeCrAl) wires, Cupronickel (CuNi), 220V	1	65
11-	Frame fabrication		1	500
12-	Copper tubes	0.375 in diameter	1	135
13-	Nanoparticles	Copper (Cu)	50	450
14-	Refrigerant	R134a, 13 Kg	1	350
15-	Pluming	1 in, 0.5 in	1 each	25
16-	Nuts & Nipples	0.25, 0.375		30
17-	Transmitter	ultrasonic waves poducer	3	120
18-	Bread board		1	25
19-	Transistor	2N2222 A	4	25
20-	Resistor	1.2 - 1 - 2.2 kΩ	12	6
21-	Capacitor	100* (10 ⁻¹²)F	1	25
22-	Battery	12 Volts	2	80
23-	Timer 555		1	10
24-	Wires		1 Pack	15
25-	Tank Fabrication		2	100
26-	silicon	waterproof	1	27
28-	M-seal		4	24
29-	Smart Scale	accuracy up to 0.000 g	1	270
30-	Ammeter		1	80
TOTAL COST				4317 SAR

Appendix C

Tests and Experiments

Table C.1: Reference reading

Water	evapora tor	compre ssor						
T 2	T 1	T	T out	T in	P 2	P 1	Time	
	19.1	1.7	67.7	23.5	155	20	0.2	
	18.7	1.2	68.6	23.8	155	20	0.4	
	18.6	0.5	68.6	23.8	160	19	1	
	18.3	0	68.6	24.2	160	19	1.2	
	18	0	67.6	24.3	160	19	1.4	
	17.5	2.2	69.4	23.6	160	19	2	
	17.3	3.4	69.4	23.5	160	19	2.2	
	17.2	1	69.4	23.9	160	17	2.4	
	17	0	69.4	24.1	160	17	3	
	17	0	69.4	24.1	155	17	3.2	
	16.5	3.4	69.4	23.6	155	17	3.4	
	16.2	0.5	69.4	23.6	165	20	4	
	16.1	0	69.4	23.8	150	20	4.2	
	16	-2	69.4	24.1	150	15	4.4	
	15.8	-1.8	69.4	24.1	150	15	5	
	15.5	1.7	69.4	23.8	160	20	5.2	
	15.2	3.2	69.4	23.9	160	22	5.4	
	15.1	1.5	69.4	23.9	155	20	6	
	15	0.2	69.4	23.9	155	18	6.2	
	14.8	0	69.4	23.6	155	17	6.4	
	14.5	2.5	68.6	23.9	155	19	7	
	14.5	2.7	68.6	23.6	155	20	7.2	
	14.4	1	68.6	23.8	155	20	7.4	
	14.1	0	68.6	23.9	155	18	8	
	14.1	0	68.6	23.8	150	17	8.2	
	13.8	1.7	68.6	23.5	150	19	8.4	
	13.7	2.5	68.6	23.6	155	20	9	
	13.4	0.5	68.6	23.7	155	19	9.2	
	13.2	0	68.6	23.8	155	17	9.4	
	13.2	1.2	68.6	23.6	160	20	10	
	13	1.7	68.6	23.3	160	20	10.2	
	13	1.5	68.6	23.4	155	20	10.4	
	12.6	0.7	69.4	23.6	160	19	11	
	12.6	0.2	69.4	23.6	155	19	11.2	
	12.5	1	69.4	23.6	160	19	11.4	
	12.3	1.5	69.4	23.4	155	20	12	
	12	0.2	69.4	23.7	155	19	12.2	
	11.6	-1	69.4	32.8	150	18	12.4	
	11.5	0	69.4	23.6	150	16	13	

	11.5	1.5	68.6	23	155	20	13.2
	11.3	1	68.6	23.3	155	20	13.4
	11	0.2	69.4	23.1	160	20	14
23.4	11	0.2	69.4	23.1	155	17	14.2
21.9	11.1	0.7	669.4	23	155	18	14.4
20.7	11.1	0.7	68.6	23.3	160	20	15
20.8	11.8	0	69.4	23	155	19	15.2
20.5	11.8	0	69.4	23.4	155	18	15.4
20.5	11.3	2.7	69.4	23.4	155	20	16
20.2	11.2	3.6	69.4	23.1	165	23	16.2
19.5	11.1	1.2	69.4	23.3	165	21	16.4
18.6	11.1	-1.5	69.4	23.3	160	16	17
19.3	11.3	0.2	69.4	22.2	150	18	17.2
19.1	16.7	2.7	68.6	22.1	150	20	17.4
19.1	16.6	2.7	68.6	21.3	160	20	18
19.3	16.6	0.5	68.6	21.9	155	19	18.2
19.5	16.9	0	68.6	21.9	155	17	18.4

Table C.2: Nano 0.1 g/L of Nano added

Water	evaporator	compressor					
T 2	T 1	T	T out	T in	P 2	P 1	Time
	19.2	-1	67.7	23	145	16	0.2

	18.3	0	67.7	23.1	145	17	0.4
	18.1	0	67.7	23.3	145	17	1
	17.8	0	67.7	23.1	145	17	1.2
	17.5	-1	67.7	23.1	145	17	1.4
	17.5	-1	67.7	23	140	16	2
	17.2	0	67.7	23.2	140	16	2.2
	17.1	0	67.7	23.1	140	16	2.4
	16.7	0	67.7	22.9	140	16	3
	166.5	-1	67.7	22.9	140	16	3.2
	16.4	0	67.7	22.8	140	16	3.4
	15.8	0	67.7	22.8	140	16	4
	15.8	0	67.7	22.6	140	16	4.2
	15.5	0	67.7	22.6	140	16	4.4
	15.2	0.2	67.7	22.6	140	16	5
	15.1	0.2	67.7	22.7	140	17	5.2
	15	0	67.7	22.8	140	17	5.4
	14.7	-1.3	67.7	22.6	140	17	6
	14.5	-1.5	67.7	22.6	140	17	6.2
	14.4	-1.3	67.7	22.6	140	17	6.4
	14.2	-1	67.7	22.9	140	17	7
	14	0	67.7	22.8	140	17	7.2
	13.7	0	66.9	22.6	140	17	7.4
	13.7	0	66.9	22.6	140	17	8
	13.7	0	66.9	22.9	140	17	8.2
	13.4	0	66.9	22.9	140	17	8.4
	13.1	0	66.9	22.8	140	17	9
	13	0	66.9	22.8	140	17	9.2
22.6	12.5	-1	66.9	22.6	140	17	9.4
20.9	12.3	0	66.9	22.6	140	17	10
20.3	12.8	0	66.9	22.6	140	17	10.2
20.3	14.4	0	66.9	22.4	140	17	10.4
20.2	17.8	0	66.9	22.1	140	16	11
20.2	17.9	0.7	66.9	22.1	140	16	11.2
20.2	18	1.2	66.9	22.3	150	19	11.4
20.3	18.3	0.5	66.7	22.1	150	19	12
20.1	18.5	0.2	66.7	22.4	150	19	12.2

Table C.3: 0.3g/L of Nano added

Water	evaporator	compressor
-------	------------	------------

T 2	T 1	T	T out	T in	P 2	P 1	Time
	19.2	3	66.9	22.8	150	20	0.2
	18	2.2	66.9	22.8	150	20	0.4
	17.7	1.5	66.9	22.8	150	20	1
	17.5	0.7	66.9	22.9	150	20	1.2
	16.7	1	66.9	22.6	150	20	1.4
	16.4	0.7	66.9	22.6	140	20	2
	16.4	0.7	66.9	22.9	140	20	2.2
	16.2	0.7	66.9	22.7	140	19	2.4
	15.8	1	66.9	22.6	140	19	3
	15.4	1.2	66.9	22.9	140	19	3.2
	15.4	1.2	66.9	22.8	140	19	3.4
	15.1	1.5	66.9	22.6	140	19	4
	15	1.5	66.9	22.6	140	19	4.2
	14.7	1.2	66.7	22.6	140	19	4.4
	14	1	66.7	22.5	140	19	5
	14.2	0.7	66.9	22.4	140	19	5.2
	14	0.7	66.9	22.4	140	19	5.4
	13.8	1	66.9	22.3	140	19	6
	13.7	1	66.9	22.2	140	19	6.2
	13.5	1	66.9	22.1	140	19	6.4
	13.4	1.5	66.9	22.4	140	19	7
	13	1.5	66.9	22.4	140	19	7.2
	13	1.2	66.9	22.4	140	19	7.4
	12.8	1.2	66.9	22.3	140	19	8
	12.6	1.2	66.9	22.3	140	19	8.2
	12.5	1	66.9	22.2	140	19	8.4
	12.3	0.7	66.9	22.1	140	19	9
21.4	12.1	1	66.9	22.1	140	19	9.2
20.1	11.8	1	66.7	22.4	140	19	9.4
20.6	14.7	1.2	66.7	22.2	140	19	10
20.1	16.7	2.2	66.9	22.3	140	19	10.2
19.8	16.9	2.2	66.9	22.1	140	19	10.4
19.6	17.3	2.2	66.9	22.1	140	19	11
19.6	17.2	0.7	66.9	24.7	140	19	11.2
19.8	16.8	0.7	66.9	22.7	140	19	11.4
20	17.2	0.7	66.7	21.2	140	19	12
19.8	17.5	0.7	66.7	21.9	140	19	12.2

Table C.4: 0.5g/L of Nano of Nano added

Water	evaporator	compressor					
T 2	T 1	T	T out	T in	P 2	P 1	Time

	19.2	1.2	67.5	22.6	150	20	0.2
	18	0	66.7	22.6	145	17	0.4
	16.1	0	66.7	22.6	140	16	1
	15.7	0.7	66.7	22.9	145	19	1.2
	15.7	1	66.7	22.8	245	19	1.4
	15.7	1.5	66.7	22.6	145	19	2
	15.6	1.5	66.7	22.4	145	18	2.2
	15.4	0	66.7	22.4	145	18	2.4
	14.8	0	66.7	22.6	150	18	3
	14.6	0.7	66.7	22.4	150	20	3.2
	14.5	1.2	66.7	22.4	150	20	3.4
	14.4	0.7	66.7	22.9	140	20	4
	14.1	1.2	66.7	22.7	130	15	4.2
	13.9	0.7	66.7	22.9	140	14	4.4
	13.8	1.2	66.7	22.9	145	14	5
	13.4	0.7	66.7	22.9	145	18	5.2
	13.1	0.7	66.7	22.8	145	14	5.4
	12.8	1	66.7	22.4	150	20	6
	12.6	0	66.7	22.1	150	18	6.2
	12.6	0.7	66.7	22.1	145	19	6.4
	12.5	0.2	66.7	22.3	145	20	7
	12.1	0.2	67.5	22.4	145	19	7.2
	11.5	-1.3	67.5	22.1	145	17	7.4
	11.4	-1	66.7	22.1	145	18	8
	11.2	0.2	66.7	22.4	145	19	8.2
	11	0	66.7	22.4	145	19	8.4
22.3	10.7	-0.5	66.7	22.1	145	17	9
20.7	10.9	-1.5	66.7	22.1	140	16	9.2
20.6	15.4	-1.5	67.5	21.8	150	19	9.4
20.1	15.7	-1	66.7	21.6	150	18	10
20.2	16	-1.8	67.5	21.9	150	19	10.2
19.8	15.4	-1.5	67.5	22	150	20	10.4
19.6	15.2	-1.5	67.5	21.9	150	19	11

Appendix D

SolidWork

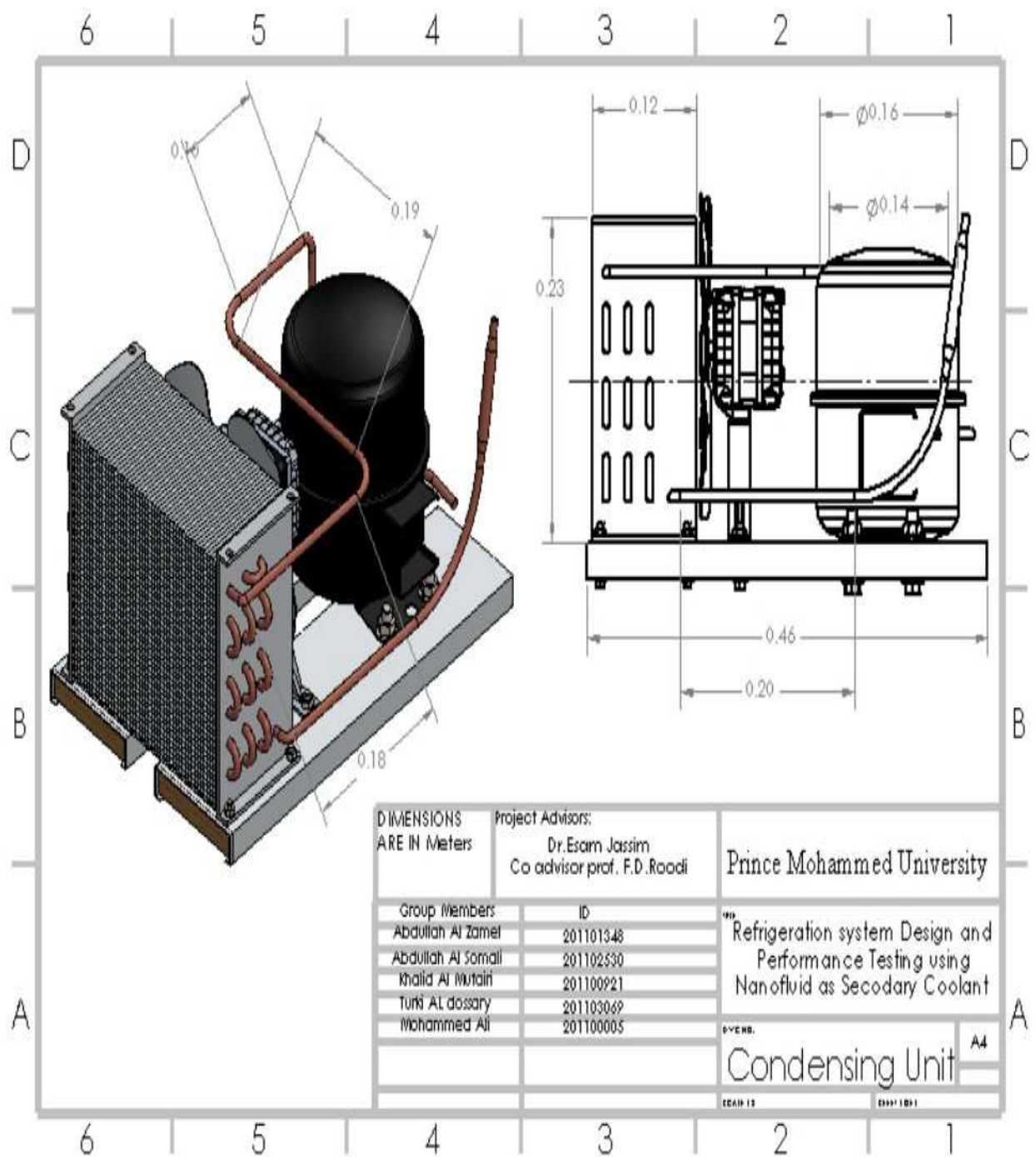

Figure D.1 Condensing unit

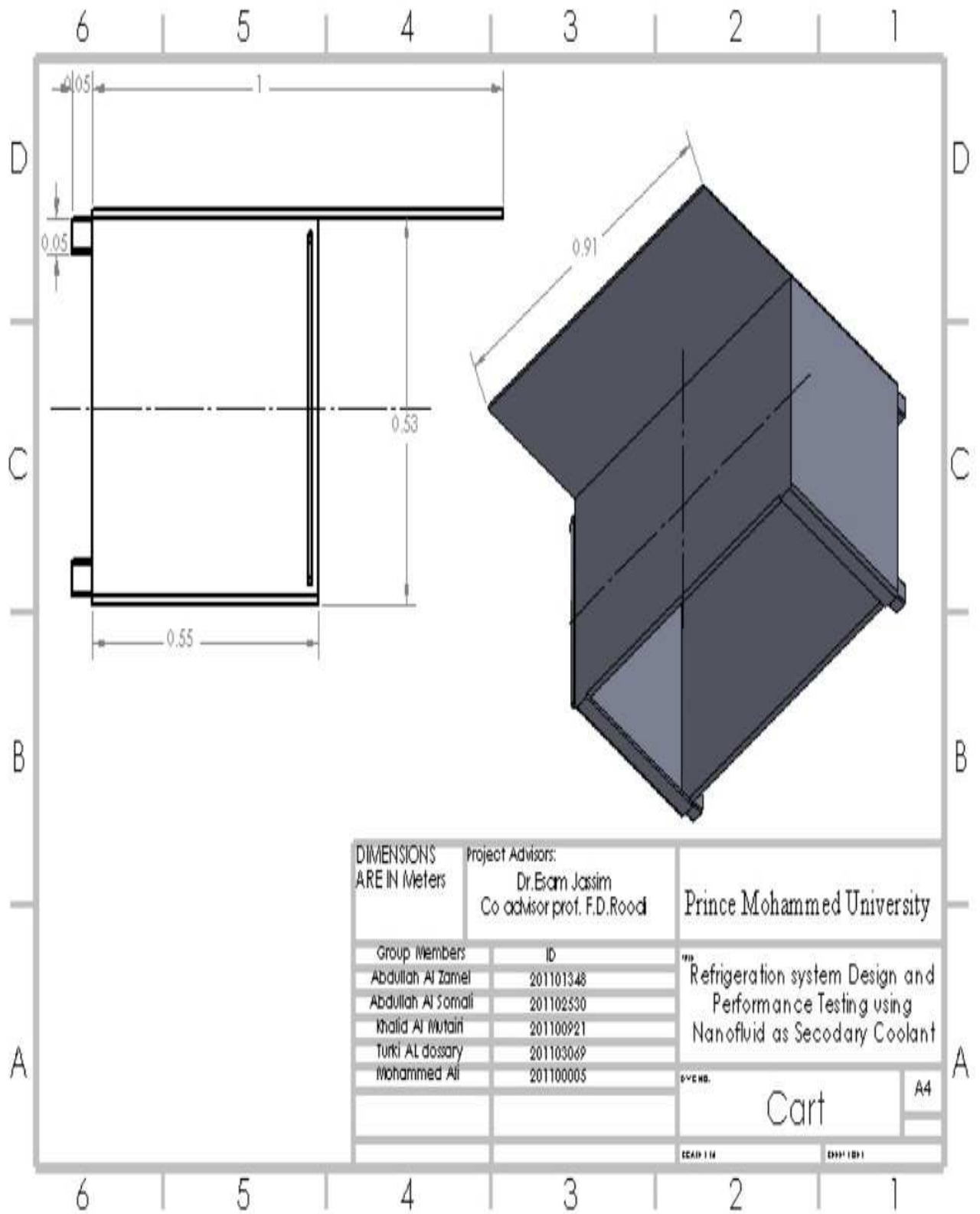

Figure D.2 Cart

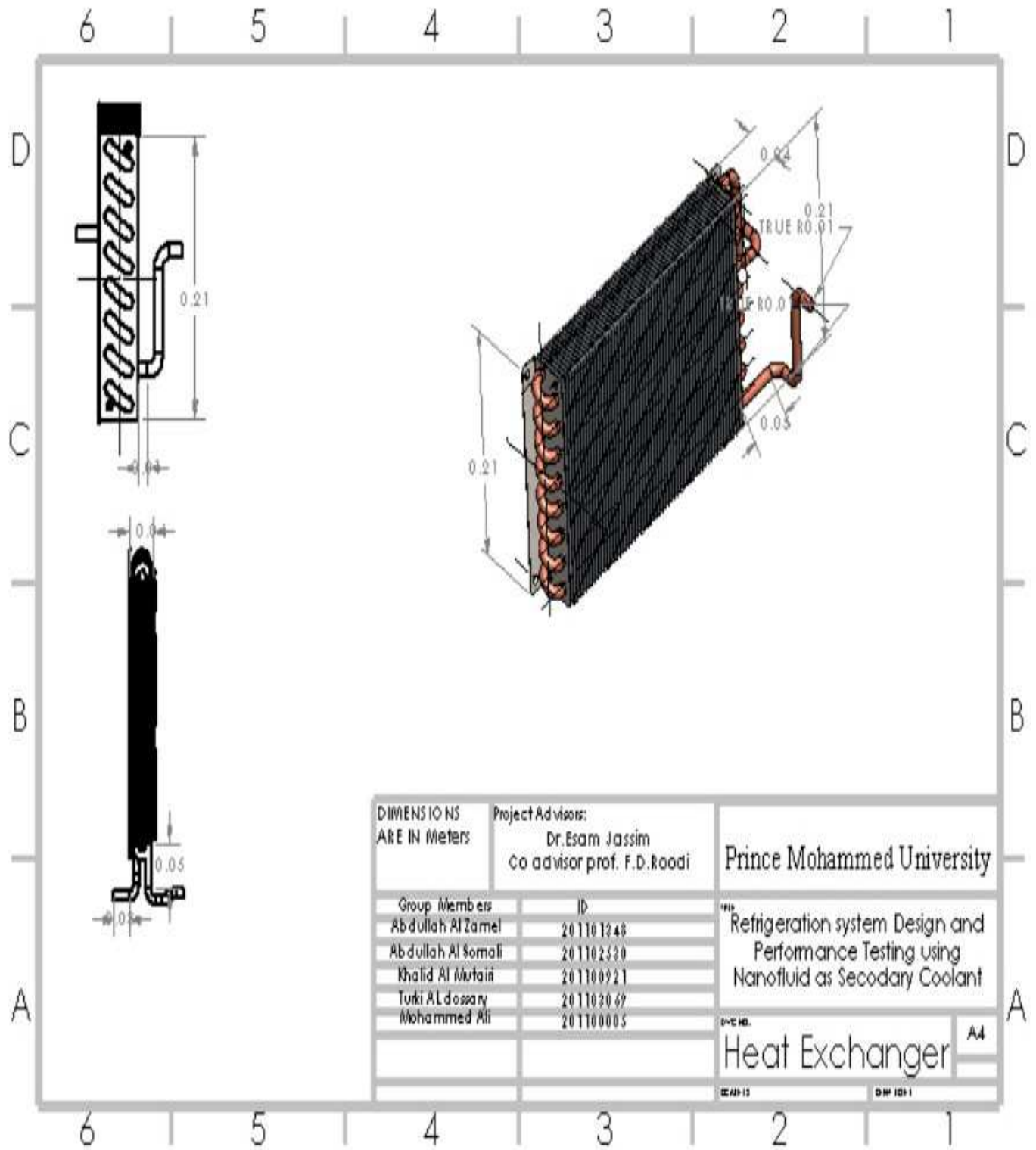

Figure D.3 Heat Exchanger

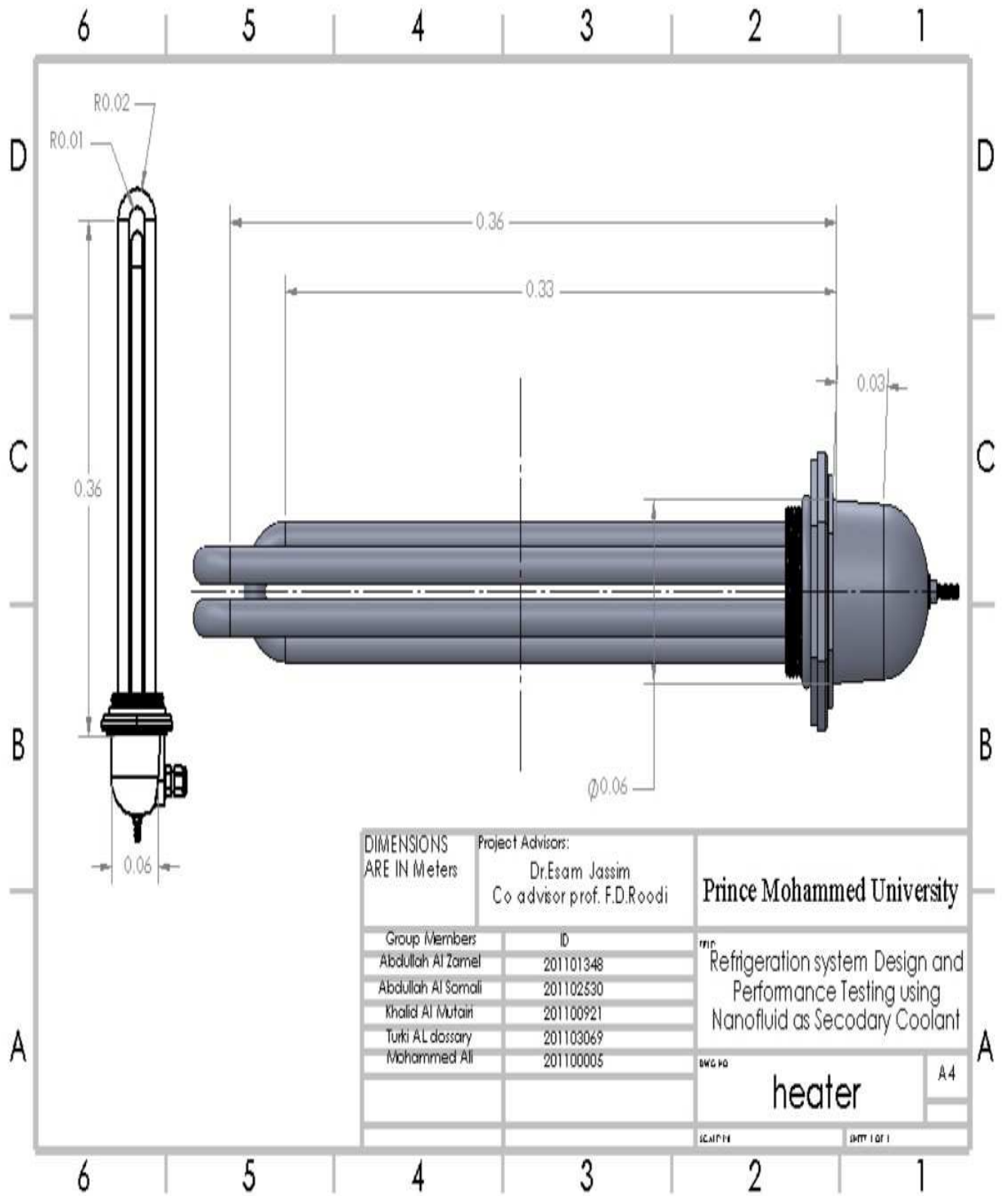

Figure D.4 Heater

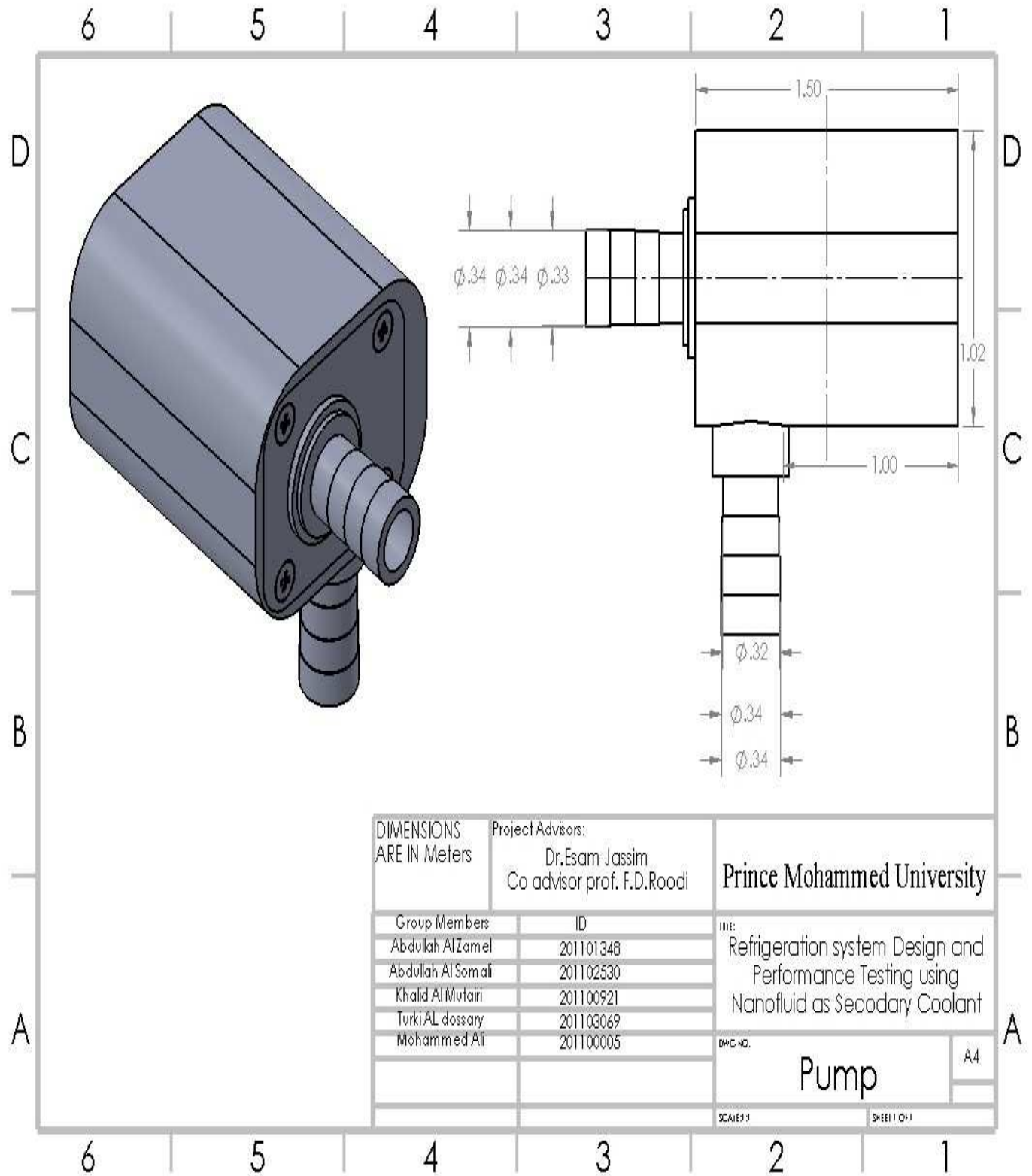

Figure D.5 Pump

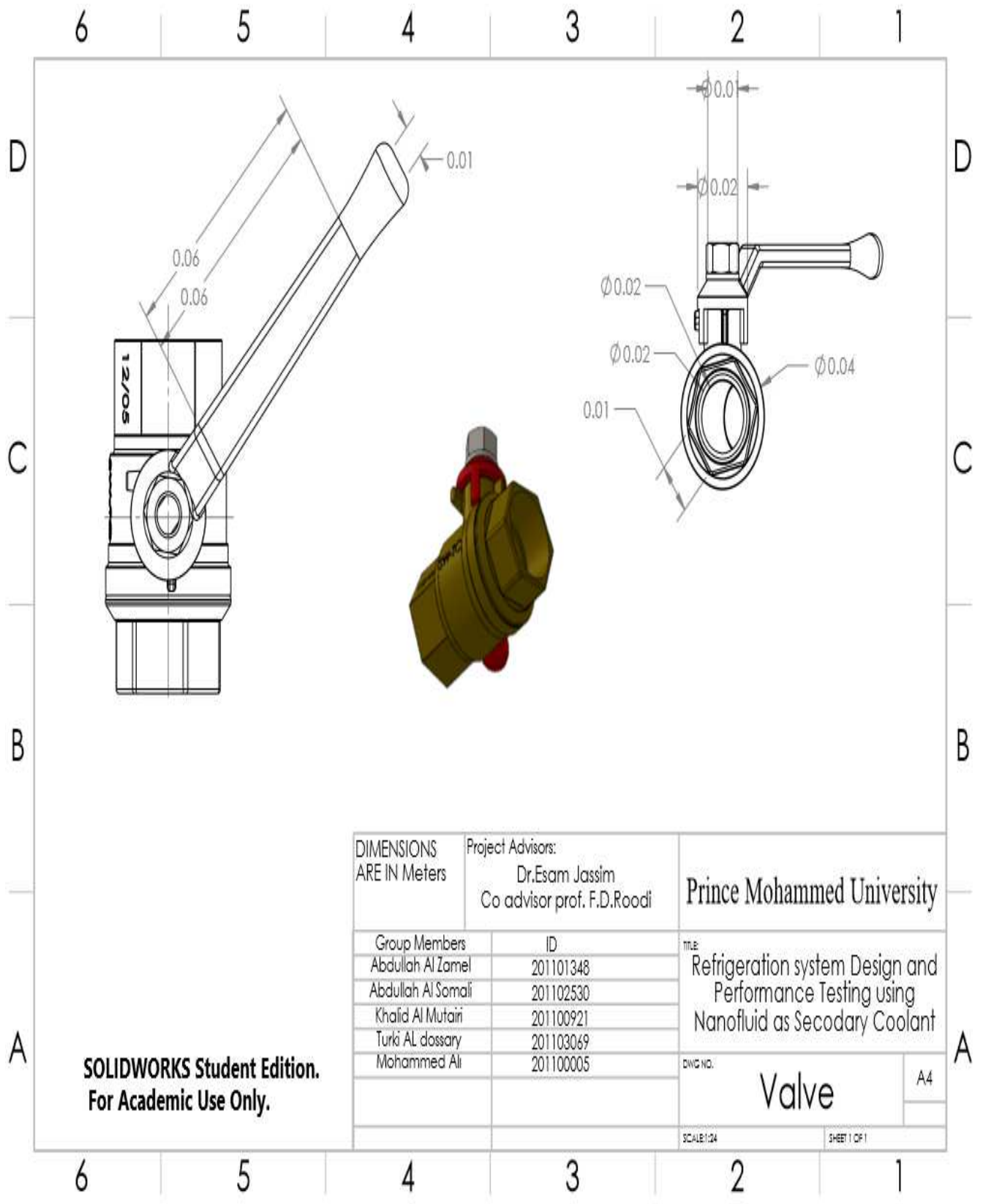

Figure D.6 Valve

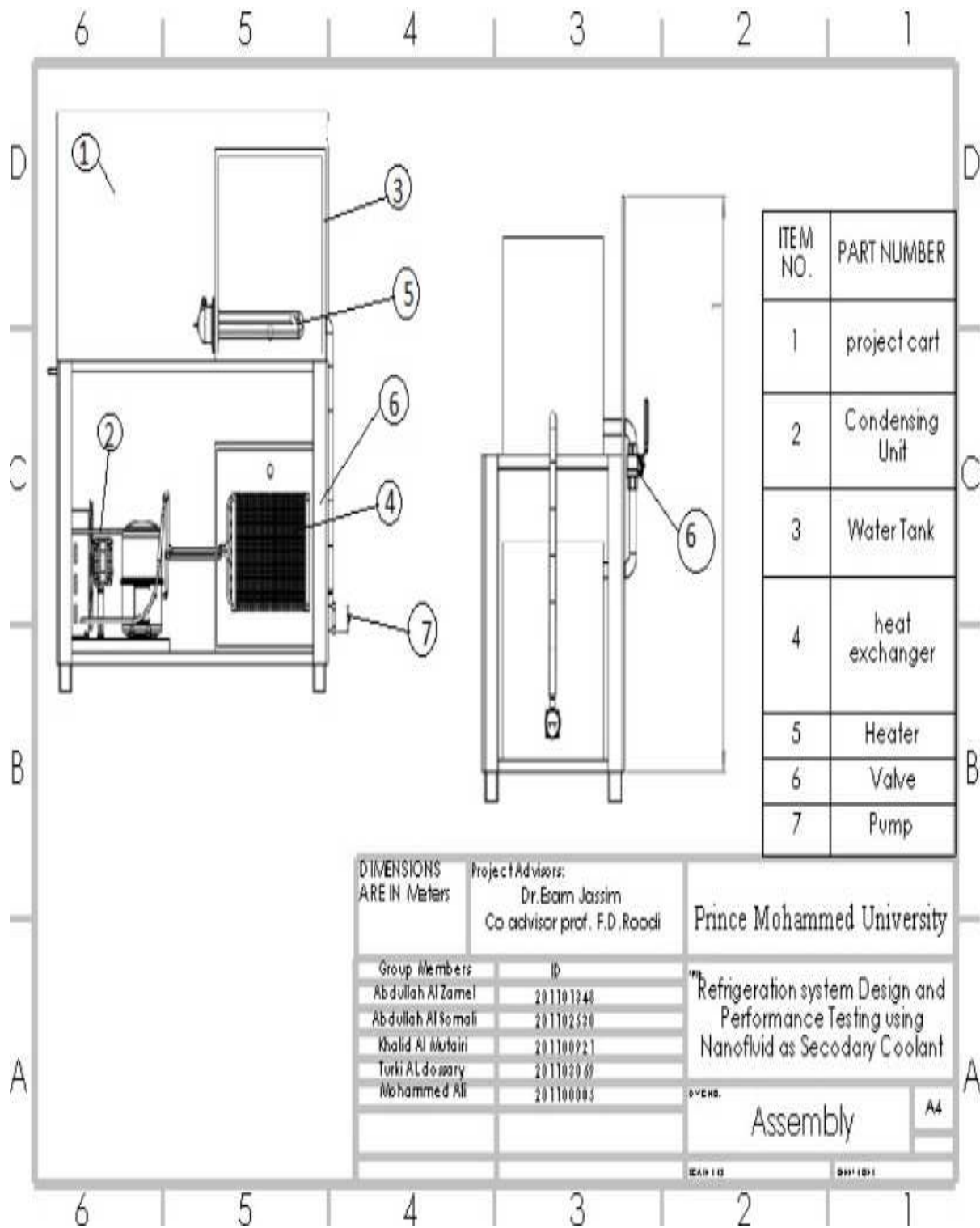
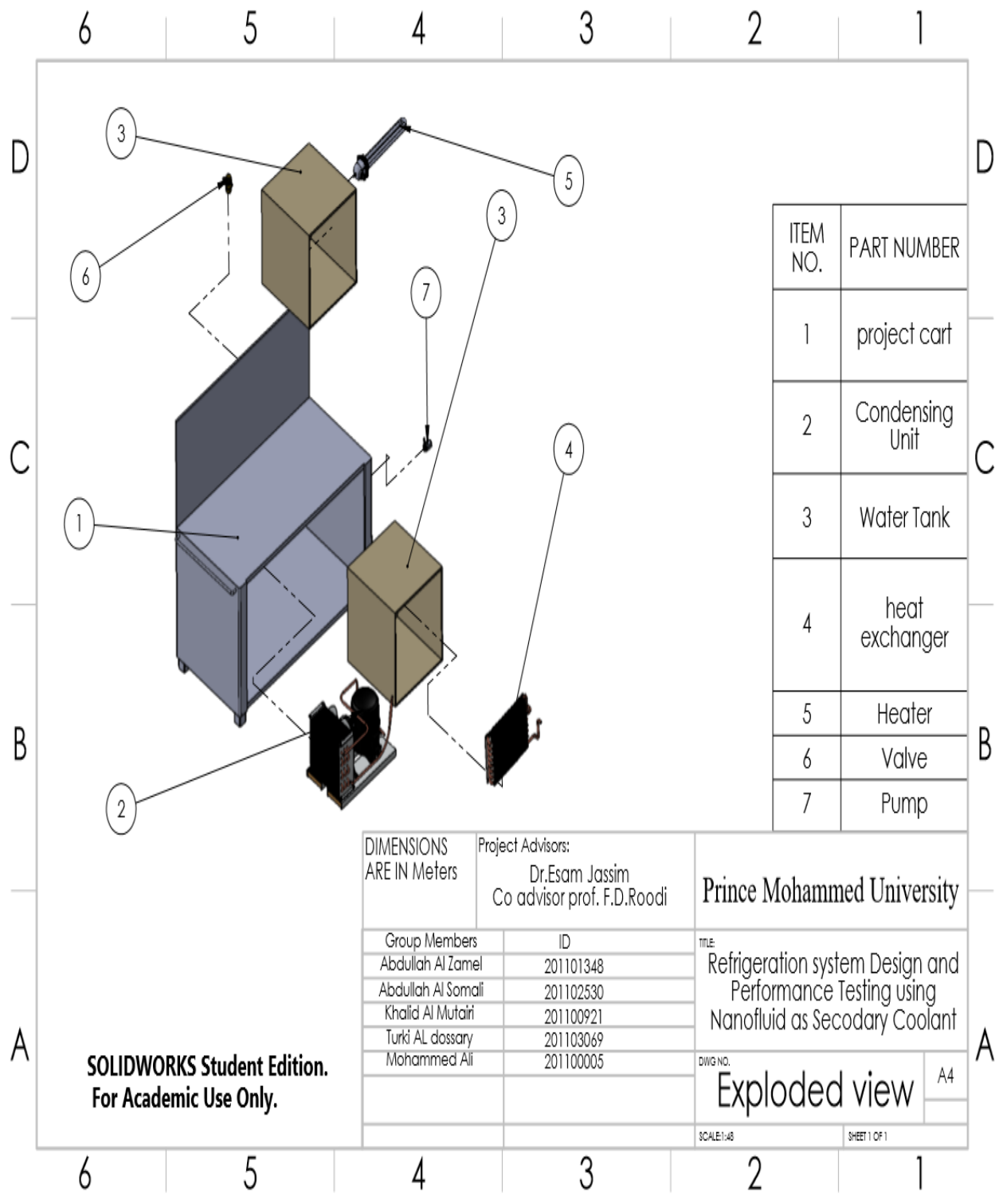

Figure D.7 Assembly

DIMENSIONS ARE IN Meters	Project Advisors:	Prince Mohammed University
	Dr. Esam Jassim Co advisor prof. F.D. Roodi	
Group Members	ID	"Refrigeration system Design and Performance Testing using Nanofluid as Secondary Coolant"
Abdullah Al Zamel	201101248	
Abdullah Al Somali	201102530	
Khalid Al Mutairi	201100921	
Turki Al doosary	201102069	
Mohammed Ali	201100005	DESIGN: Assembly A4



ITEM NO.	PART NUMBER
1	project cart
2	Condensing Unit
3	Water Tank
4	heat exchanger
5	Heater
6	Valve
7	Pump

DIMENSIONS ARE IN Meters		Project Advisors: Dr.Esam Jassim Co advisor prof. F.D.Roodi	
Group Members		ID	
Abdullah Al Zamel		201101348	
Abdullah Al Somali		201102530	
Khalid Al Mutairi		201100921	
Turki AL dossary		201103069	
Mohammed Ali		201100005	

Prince Mohammed University	
TITLE: Refrigeration system Design and Performance Testing using Nanofluid as Secodary Coolant	
DWG NO.	A4
Exploded view	
SCALE:1:48	SHEET 1 OF 1

**SOLIDWORKS Student Edition.
For Academic Use Only.**

Figure D.8 Assembly Exploded View

Appendix E

Operation manual



Figure 1: Actual Footage of the System.

A: Fill the two tanks with 40 L of water.

1- Turn on the heater to reach the desired temperature for the water.

2- Turn on the condensing units.

3- Wait couple of minutes before start recording data.

- 4- Once the temperature of the water reach 10 Celsius open the valve and turn on the pump.
- 5- On the experiment continue running the experiment and taking data until reaching the steady state.

B: Charging the system:

To charge the system with R134A

1. Connect the hose to the cylinder and the mini fold gage.
2. Open the valve for the low pressure gage.
3. Open the valve of the cylinder.
4. Charge the system with the small amount of R134A.
5. Close the valves and turn on the condenser units.
6. Re-charge yes the system by open the valve and close it repeatedly until the low pressure gauge reach 20 psi.

C: To charge the system with nanoparticles

1. Prepare the calculated amount of nanoparticles.
2. Insert the nanoparticles in the charging hose.
3. Open the cylinder valve to boost the nanoparticles in the system.



Refrigeration system design and performance testing using Nanoparticles as a secondary coolant

Advisor : Dr. Essam Jasim

CO Advisor: Dr. Faramarz Djavanroodi

TURKI ALDOSSARY 201103069 MOHAMMED ALI 201100005

ABDULLAH AL ZAMEL 201101348 KHALID AL MUTAIRI 201100921

ABDULLAH AL SOMALI 201102530

Outline

- Introduction
- Objectives
- Background
- Design
- Results
- Time table
- Challenges
- Recommendations
- Conclusion

Introduction

- Cooling system is needed in every single house. Cooling devices in refrigeration systems require a high rate of energy consumption to offset the cooling load of a comfort zone.
- Considerable attention has been recently given to Nanoparticles as a secondary coolant in vapor compression refrigeration system that enhances the thermal properties of the refrigerant.

Objectives

- Design and build a basic refrigeration system (vapor compression refrigeration cycle) to use it as a test apparatus.
- Studying the effects of adding copper Cu nanoparticles as a second coolant into the refrigerant (R134a).

Background

- Nano Particles technology:

- What's Nanoparticles?

Particles in Nano scale (**1 mm = 1,000,000 nm**), some thermal & physical properties enhancement compered to the bulk materials.”

High Surface Area: Volume ratio.

- Shapes of Nanoparticles.

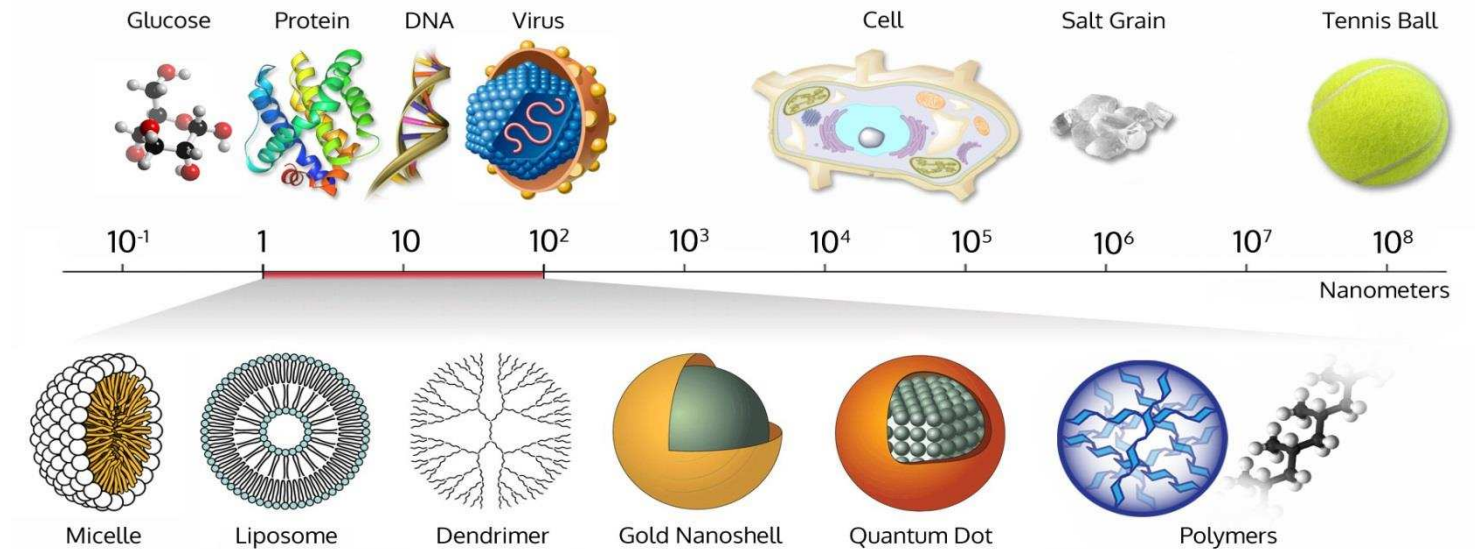

Synthesizing Nanoparticles

- **Top-Down approach.**

using detonation (explosion) or high energy of ultrasonic sounds waves to break up materials from mm to nm scale.

- **Bottom-Up approach.**

water and soluble form of the material, chemical reactions occurs to produce nano-scale ions of the material.

System Design

- Block diagram of the designed system

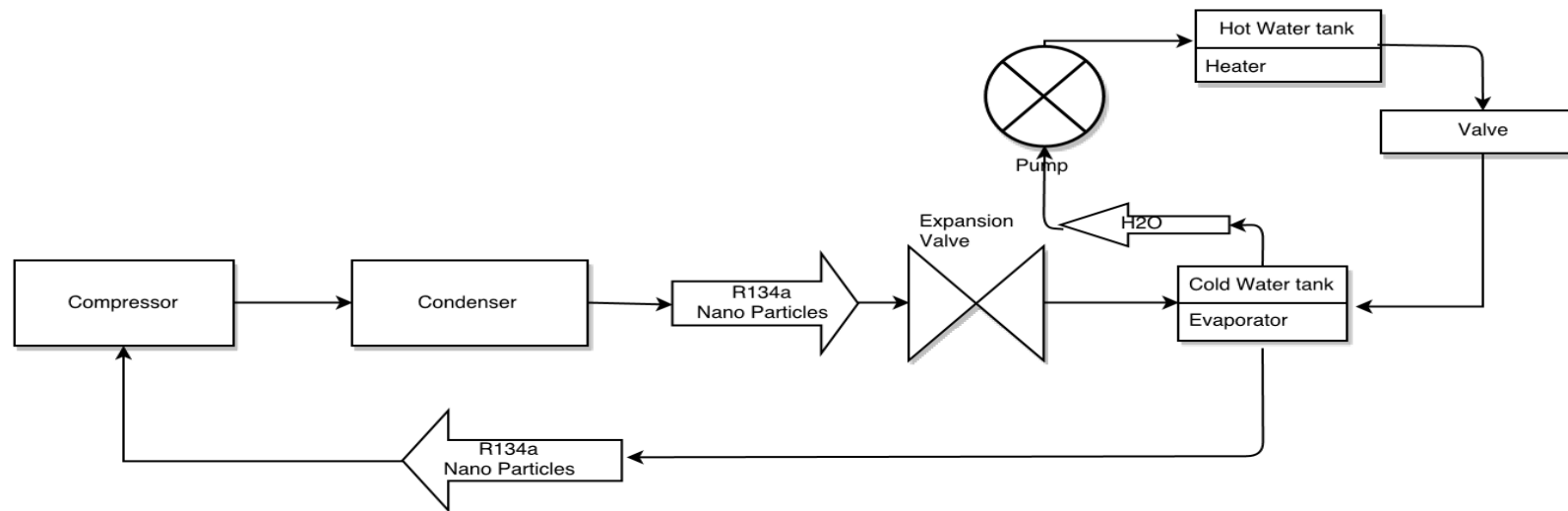

BOM

#	Bill of Materials	Specifications	Quantities	Price (SAR)
1-	Compressor	100 watts, 1/3 HP, 220V, 60Hz	1	900
2-	Evaporator	Made of copper tubes & aluminum fins, Copper tube \varnothing 1/2 inch, Multiple aluminum fins, Suitable for R134A, R22, R404A, R407C refrigerant, Capacity of 1/3HP.	1	200
3-	Capillary		1	15
4-	Pump	Power 80W, Voltage 220V ,Frequency 220V/60Hz, Total head 2.5m,Flow rate 2800L/H, Continues	1	140
5-	Condenser	Horizontal condenser	1	0
6-	Water tanks	120 liter, Made of PVC, Has two inlets , one is half inch, and the other one is 1 inch , 2 layers of insulation, 120 liter, Made of PVC. Has two inlets one is half inch and the other one is 1 inch 2 layers of insulation.	2	200 each
7-	Tempretares gage	For R134a	3	60 each
8-	Pressure gage	For R134a	3	40 each
9-	Tempretares gage	For water	2	60 each
10-	Heating coil	80% nickel, 20% chromium, Kanthal (FeCrAl) wires, Cupronickel (CuNi), 220V	1	65
11-	Frame fabrication		1	500
12-	Copper tubes	0.375 in diameter	1	100
13-	Nanoparticles	Copper (Cu)	50	450
14-	Refrigerant	R134a, 13 Kg	1	350
15-	Pluming	1 in, 0.5 in	1 each	25
16-	Nuts & Nipples	0.25 , 0.375		
17-	Transmitter	ultrasonic waves poducer	3	40 each
18-	Bread board		1	25
19-	Transistor	2N2222 A	4	
20-	Resistor	1.2 - 1 - 2.2 k Ω	12	6
21-	Capacitor	100*(10 ⁻¹²)F	1	
22-	Battery	12 Volts	2	40 each
23-	Timer 555		1	
24-	Wires		1 Pack	15

Experiment procedure

- Testing the performance of the system
- Recording data without adding Cu Nanoparticles
- Adding Nanoparticles in three different concentrations
- Measuring the performance of the system after adding Nanoparticles
- Analyzing data

Ultrasonic Transmitter

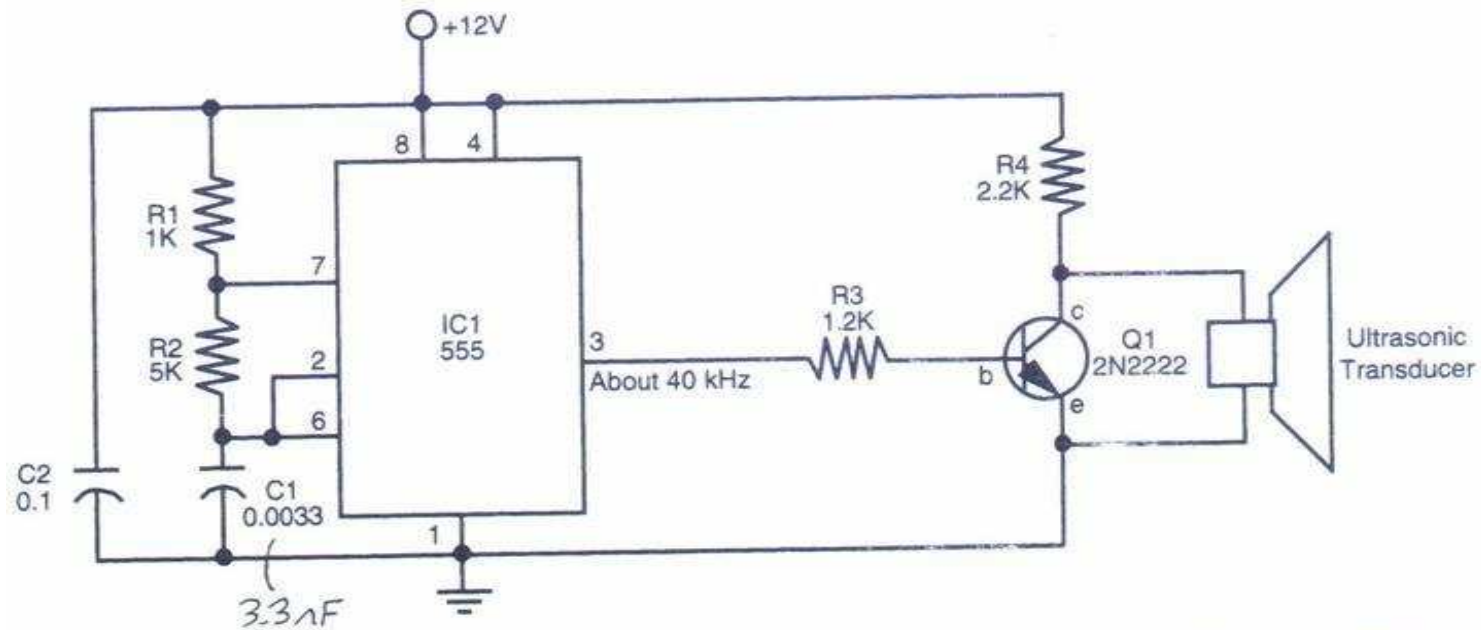

Schematic diagram for a basic ultrasonic proximity transmitter.

Results

- Overall results:

1-Improvement in the cooling load of the system 2-Reduction in power consumption.

Water Tank Temperature C

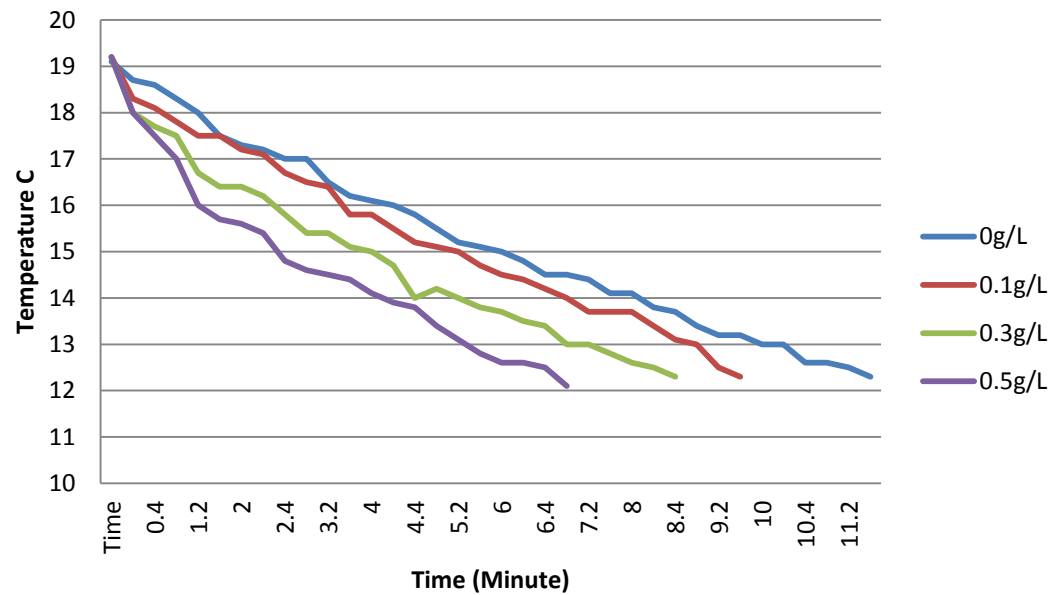

Power Consumption (kW.h)

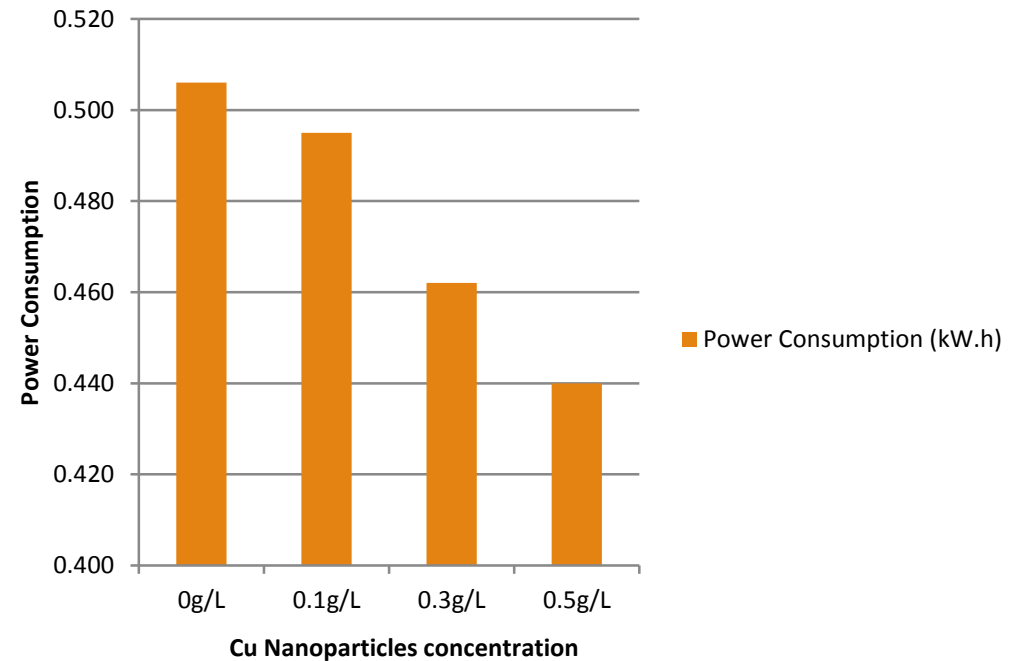

Results

Comparison between our results and Vinayaka Missions University results which been conducted in 2015

University	Nanoparticles Type	Refrigerant Type
Prince Mohammed university	Cu	R134a
Vinayaka Missions university	CuO	R600

Results

Comparison between
the two result

Concentration (g/L)	0 g/L	0.1g/L	0.3g/L	0.5g/L	Concentration(g/L)	0	0.1	0.5
Power Consumption (kWh)	0.506	0.484	0.462	0.44	Energy Consumption(kWh)	0.9567	0.8435	0.7856
Power Reduction	0%	4.30%	8.70%	13.10%	Energy Savings(%)	-	11.83	17.88

Prince Mohammed
University

Vinayaka Missions
University

Timetable

Week	Main task
1	Project design stage 1
2	Market survey
2	Project design stage 2
3	Virtual design
3	Final design stage
4-5	Purchasing parts
6	Manufacturing the frame
7-8	Installing the refrigeration system
8	Installing the water system
8	Completing apparatus installation
10	Testing the integrity of the apparatus
11	Starting the data collection
11	Collecting data stage #1
12	Inserting Nanoparticles
12	Collecting data stage #2
13-14	Data analysis
15	Finalizing the final report

Challenges

- Leakage
- Evaporator
- Temperature gauges
- Nanoparticles
- Nanoparticles mixing

Recommendations

- Using different types of Nanoparticles
- Using different types of refrigerants
- Apply Nanoparticles as a compressor lubricant (Nano lubricant)
- Upgrading the cooling system for bigger unit.

Conclusion

- Designing and testing refrigeration system
- Enhancing the performance of refrigeration system using Copper Nanoparticles
- Reducing the power consumption by 13%

Thank you for listening

