



جامعة الأمير محمد بن فهد الأهلية
PRINCE MOHAMMAD BIN FAHD UNIVERSITY

College of Engineering

Department of Mechanical Engineering

Spring 2016-2017

Project Title

*Torsional property of Nano Structured Titanium for use in Biomedical
Application*

Team (10) Members

Student Name	Student ID
Ahmad Al-Ahmad	201102813
Ahmed Al-Zahrani*	201300471
Masoud Al-Mari	201301057
Mohammed Al-Shehri	201300159
Saleh Al-Shammeri	201203373

Project Advisors:

Advisor: Dr.Famarz Djavanroodi

Co-advisor: Dr. Nader Sawalhi

June 2017

ABSTRACT

The field of biomaterials has become a vital area, as these materials can enhance the quality and longevity of human life and the science and technology associated with this field has now led to multi-billion dollar business. It is well known that a good biomaterial should possess the fundamental properties such as better mechanical and biological compatibility and enhanced wear and corrosion resistance in biological environment. This project focuses its attention mainly on Nano structure pure titanium, even though there exist biomaterials made up of ceramics, polymers and composite materials. Also, we will discuss the biomechanical compatibility of many metallic materials, attention will also be given to the overall superiority of Nano structured Ti, even though it is costlier. In this work, savior plastic deformation is used to produce Nano structure Ti. The torsional property of Nano structured will be tested according to ASTM standard and will be assessed if it meets the requirement of biomaterial.

The results show an increase in the strength of the pure titanium after the ECAP. The maximum torque that the material can withstand increased by 44.85% before fracture. The maximum shear stress for the material increased by 44.6%. The yield and proportionality shear stresses both increased by 165% and 142% respectively. The ductility of the material decreased by 62.4%. Finite element analysis have been performed to find the torsional property of the pure titanium. The results show that there is 20% difference between the experimental and numerical analysis.

Keywords: Titanium, Pure titanium, Micro-structure, Nano-structure, ECAP, Mechanical properties, Strength, Ductility.

ACKNOWLEDGMENT

This is the time that we have completed our education at Prince Mohammad Bin Fahad University and got our bachelor's degree and also it is the time to remember all the class and all the hours we spend inside and outside PMU .We would like to thank our project advisor Dr.Faramarz Djavanrood and Co-advisor Dr. Nader Sawalhi for their continuous support. Their offices were always open for any question we had about the research. They allowed us to do our own work and guided us through the right direction. We would also like to thank Prince Mohammad bin Fahd University for facilitating the equipment and tools needed for this project.

We are thankful also to the engineering department because of whom ; we have learned new skills and gained a lot of knowledge and abilities which will helps us in the future in our life or in our daily jobs to be a professional engineer . We are also thankful to Prince Mohammad Bin Fahad University as a whole which the doors were always open for us as a students, labs provided in our university which helped us to do our studies and complete our research to show the people a great work provided by the students of Prince Mohammad Bin Fahad University.

We are also grateful to ALQASSIM University for welcoming us in their labs to complete our project .At last we would like to thank our families for their support and without them we won't reach to this point .In addition thanks to the Fluid Codes company, especially Mr. Krunal Patel and Mr.Mohammed zaid for their help and excellent communication to complete our project. Also our machining was on Modern Precision Engineering we thank them for letting us use the machines .We would like again to thank all the mechanical engineer department for this opportunity.

Acronyms

ECAP	Equal Channel Angular Pressing
SPD	Severe Plastic Deformation
CP Ti	Commercially Pure Titanium
FEM	Finite Element Model
ASTM	American Society for Testing and Materials
UFG	Ultra-fine grained
CNC	Computer Numerical Control

LIST OF FIGURES

FIGURE 2.1: DIFFERENCE IN OSTEOBLAST ADHESION OF CONVENTIONAL AND ULTRA-FINE GRAIN, RETRIEVED FROM [2].....	16
FIGURE 2.2: YIELD STRENGTH OF TITANIUM ALLOYS, WITH PERCENTAGE ELONGATION, RETRIEVED FROM [3]	17
FIGURE 3.1: PROJECT ARCHITECTURE DIAGRAM.....	26
FIGURE 3.2: LARGE SPECIMEN DIAGRAM.....	27
FIGURE 3.3: SMALL SPECIMEN DIAGRAM.....	28
FIGURE 3.4: SMALL SPECIMEN DIAGRAM.....	29
FIGURE 3.5: SMALL SPECIMEN DIAGRAM.....	30
FIGURE 3.6: TORSION TESTING MACHINE NDW 500.....	31
FIGURE 3.7: THE SPECIMEN AFTER THE TORSION TEST.	33
FIGURE 3.8: SCHEMATIC PRESENTATION OF THE ECAP PROCESS	34
FIGURE 3.9 DIE ECAP PROCESS AFTER ONE PASS.....	35
FIGURE 3.10: 300 MM LENGTH AND CIRCLER BASE WITH 16 MM DIAMETER COPPER	36
FIGURE 3.11: TWO SPECIMEN WITH 53.23 MM AND 36 MM LENGTH FOR TORSION TEST	37
FIGURE 3.12: CNC LATHE MACHINE.....	38
FIGURE 3.13: CNC MILLING MACHINE	38
FIGURE 3.14: 2 PASSES NANOSTRUCTURE TITANIUM WITH SCALE	39
FIGURE 3.15: 4 PASSES NANOSTRUCTURE TITANIUM 50 MM LENGTH, 22 MM DIAMETER.....	40
FIGURE 3.16: MICROSTRUCTURE PURE TITANIUM SPECIMEN 36 MM.....	41
FIGURE 3.17: PURE TITANIUM SPECIMENS WITH DIFFERENT STAGES	42
FIGURE 3.18: TITANIUM SPECIMENS WITH DIFFERENT STAGES SCALE	42
FIGURE 4.1: COMPARISON OF MAXIMUM TORQUE UNTIL FRACTURE	47
FIGURE 4.2: COMPARISON OF MAXIMUM SHEAR STRESS	47
FIGURE 4.3: COMPARISON OF SHEAR STRESS AT YIELD POINT.....	48
FIGURE 4.4: STRESS-STRAIN CURVE FOR A NORMAL TORSION TEST	49
FIGURE 4.5: STRESS-STRAIN CURVE FOR THE TORSION TEST WITH THE SLIPPAGE FOR THE 4 PASSES NANO-STRUCTURED TITANIUM SPECIMEN.	50
FIGURE 4.6: COMPARISON OF MAXIMUM TORQUE BETWEEN THE THREE TITANIUM SPECIMENS ..	51
FIGURE 4.6: COMPARISON OF ROTATION ANGLES BETWEEN THE TWO TITANIUM SPECIMENS	52
FIGURE 4.7: COMPARISON OF MAXIMUM SHEAR STRESS BETWEEN THE THREE TITANIUM SPECIMENS	53
FIGURE 4.7: COMPARISON OF SHEAR STRESS AT YIELD POINT BETWEEN THE TWO TITANIUM SPECIMENS	54
FIGURE 4.8: COMPARISON OF SHEAR STRESS AT PROPORTIONALITY POINT BETWEEN THE TWO TITANIUM SPECIMENS.....	55
FIGURE 4.9: MESH SENSITIVITY ANALYSIS OBTAINED FROM SOLIDWORKS F.E.M.	58

LIST OF TABLES

TABLE 2.1: PROPERTIES OF TITANIUM ALLOYS, RETRIEVED FROM [3].....	17
TABLE 2.2: PROPERTIES OF CP TITANIUM ACROSS PHASES OF THE ECAP TREATMENT, RETRIEVED FROM [8]	19
TABLE 4.1: COMPARISON OF SHEAR AND TENSILE STRESS VALUES.....	60
TABLE 5.1: PROJECT WORK DISTRIBUTION	64
TABLE 5.2: PROJECT BILL OF MATERIALS AND BUDGET	67

TABLE OF CONTANTS

Abstract	2
Acknowledgments	3
List of Figures:	5
List of Tables:	6
Chapter 1: Introduction	9
1.1 Early uses of biomaterials	10
1.2 Titanium alloys in biomedical	10
1.3 Economic value of biomaterials	11
1.4 Project Objectives	12
Chapter 2: Literature Review	13
2.1 Project background	14
2.2 Previous Work	15
2.3 Comparative Studies	19
Chapter 3: System Design	21
3.1 Design Constraints	22
3.2 Design Methodology	26
3.3 Implementation	32
Chapter 4: System Testing and Analysis	44
4.1 ECAP (Equal Channel Angular Pressing) Process	45
4.2 Machining	46
4.3 Experimental Torsion Test	47
4.4 Simulation	57
Chapter 5: Project Management	62
5.1 Project Plan	63
5.2 Contribution of Team Members	64
5.3 Project Execution Monitoring	65
5.4 Challenges and Decision Making	65
5.5 Project Bill of Materials and Budget	67
Chapter 6: Project Analysis	68
6.1 Life-long Learning	69
6.2 Impact of Engineering Solutions	71
6.3 Contemporary Issues Addressed	74

Chapter 7: Conclusions and Future Recommendations	75
7.1 Conclusions	76
7.2 Future Recommendations	76
8. References	78
Appendix A: Progress Report	81
Appendix B: Bill of Materials	93
Appendix C: Images of equipment and parts	94
Appendix D: Mesh sensitivity reports	104

Chapter 1: Introduction

1.1 Early uses of biomaterials

1.2 Titanium alloys in biomedical

1.3 Economic value of biomaterials

1.4 Project Objectives

Chapter 1: Introduction

1.1 Early uses of biomaterials

In the early stages of arthroplastic surgery, stainless steel (316L) was the preferred material for biomedical uses. Mainly because of its availability and ease of processing. One major issue accompanied with stainless steel is that high modulus compared to the bone modulus. This big difference in the module has major effects on bones because bones need stresses to live. Knowing that the material with a higher module will carry most of the load, the need arises for other materials offering better properties and a lower module.

People used titanium alloys in biomedical applications and it is considered to be the most attractive metallic material. Titanium and its alloys, as one of the important biomaterials for orthopedic, have been tremendously used because of their good mechanical properties as well as its excellent corrosion resistance and adequate biocompatibility.

1.2 Titanium alloys in biomedical

Ti-6Al-4V alloys play the main role in the biomedical applications for their good mechanical properties and corrosion resistance. However, their elastic modulus is more than that of human bone resulting in the problem of “stress-shielding” or osteopenia. The stress shielding effect which forms from the variance of elastic modulus between human bones and implant materials causes a reduction in bone density and results in the disassembling of implants in the long-term. In addition, the toxic vanadium (V) element in the Ti-6Al-4V alloy also creates toxic ion release near the implanted area.

The uses of titanium alloys in biomedical applications are critical and at a certain age, it may need some revision surgeries. Titanium can be used as an implant for hip, knee, and shoulder replacements. It is estimated that the number of total hip and knee replacements will rise by the end of the year 2030.

1.3 Economic value of biomaterials

When people get older that means that the need of titanium is going to rise and this kind of operation will cost a lot which leads to a strong business in the future that will attract a lot of traders to invest in this field. The population is increasing all over the world and if we focus in the provided date from the US that a lot of hip replacements is done by the end of the year 2000 and it is estimated that the numbers are going to increase by the year of 2030. In addition a lot of people are involved to do revisions of previous hip replacements. Usually people below the age of 65 there are a 30% of them that need hip replacements. However, people over the age of 65 have a life expectancy of 17.9 years. In addition, female patients at the age of 65 have a life expectancy of 19.2 years. Most of the people at age of 65 will require at least one revision surgery.

1.4 Project Objectives:

The project objective is to compare the size effect between the titanium and copper using the torsion test which will provide us with the data that we need and to achieve this comparison we machined the titanium and copper to run these tests and then we moved to the ECAP process to make our titanium stronger in order to make it compatible with the human body.

1. Production of commercially pure titanium (cp-ti) using ECAP.
2. Machining of the nano-structured Titanium.
3. Simulation of ECAP cp-ti for the torsion test.
4. Verification of Finite Element Module (F.E.M.) analysis through test.
5. Torsion test using standard.
6. Comparison of F.E.M. and tests.

Chapter 2: Literature Review

2.1 Project Background

2.2 Previous Work

2.3 Comparative Study

Chapter 2: Literature Review

2.1 Project Background

Biomaterials are important to quality and longevity of life. Fractures from falls and accidents are examples of incidences that establish significance of biomaterials. While some injuries can heal naturally, some may not and clinical measures may be necessary for restoring patients' conditions. Implants for replacing fractured bones or for supporting the bones during recovery may be necessary after an injury and establish an important role of biomaterials.

Use of biomaterial, however, is subject to criteria and such factors as the elastic modulus, hardness, strength, toughness and fatigue properties of a material must be considered before its use. Materials also wear out and use within the body requires that biomaterials be able to resist wear and corrosion. Use of a material with inferior properties, than of the material to be replaced, and sometimes even of a superior property, may have adverse effects on the recovery process.

The economic significance of biomaterials, which the multi-billion scope of its trade defines, and the competitive business environment identify the need for knowledge on the different properties for meeting the medical need of biomaterials. In addition, the evidence-based practice approach in the medical field requires reliance on evidence for best practice that could consider effectiveness and cost of a material. Titanium is one of the used biomaterials and an understanding of its properties, as well as the possibility of moderating its properties, can improve the benefits of biomaterials in the healthcare as well as engineering industry that is responsible for the development of the biomaterials.

2.2 Previous Work

Biomaterials have played an important role in their use in the body structure, but complications such as fatigue and corrosion identify the need for improvements. One of the effects of fatigue is cracking of a structure that leads to fracture, an effect that undermines the primary objective of the biomaterial. Design features such as holes and notches in a biomaterial or microstructural anomalies such as grain surfaces may cause fatigue into cracks. In addition, biomaterials undergo corrosion and wear that affect their functionalities as implants. Consequently, measures are necessary for ensuring that in addition to selection of a suitable biomaterial for an implant, development of the material and its nanostructure meets the minimum requirements for use in the body structure. Variation of alloy elements, and coating biomaterials with tin have been used to prevent fatigue and corrosion. Mechanical and heat treatments have also demonstrated effects on the microstructure of titanium alloys, and they influence the fatigue behavior of the alloys. Corrosion of platelets causes failure, and treatment solves this through transformation of structural composition [1].

Titanium, because of its inert condition that limits reactivity to body tissues and toxicity, would be preferred to its alloys for implants, but its physical properties offer a challenge. The mechanical strength and behavior of pure titanium are lower than the required level for hard tissue replacement. Even though treatments, such as the ECAP and deformation processes, according to [2], (2006), improve the strength, fatigue limit, functionality, and frictional behavior of the pure titanium, the achieved properties are still lower than the required levels for some implants. Figure 2.1 shows the difference in in osteoblast adhesion between the conventional grain and the ultra-fine grain.

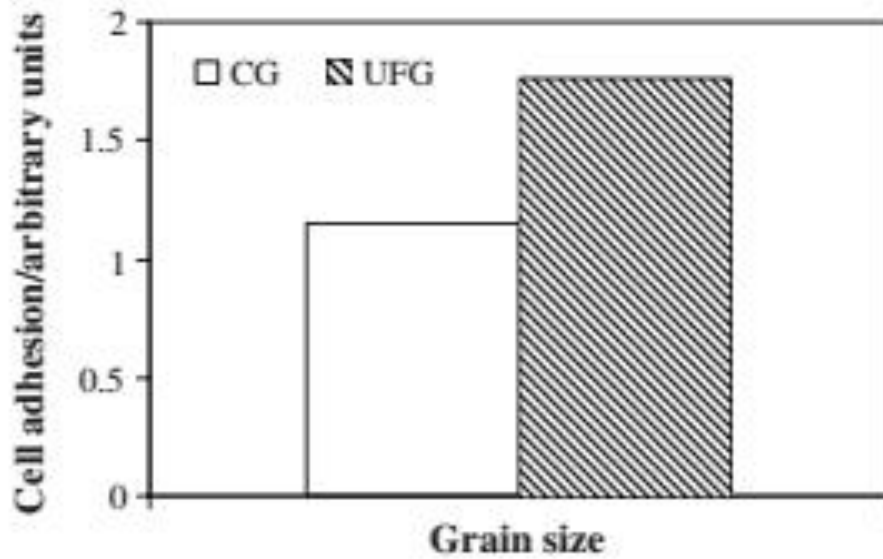

Figure 2.1: Difference in osteoblast adhesion of conventional and ultra-fine grain, retrieved from [2]

Titanium alloys, therefore, have been developed and their properties improved, through the treatment measures, to meet to needs for biomaterials [2]. The tensile strength of pure titanium, for example, ranges from 240 to 550 MPa, values that are lower than are those of titanium alloys. Ti-5Al-2.5Fe, for example has a tensile strength of 1020 MPa, almost double the highest tensile strength of the fourth grade of pure titanium. Similarly, the alloy has an almost double yield strength compared to the strength of the fourth grade pure titanium. Many other titanium alloys, such as alloys of niobium, tantalum, and zirconium, together with β -alloys, also exist and have superior properties to those of the developed pure titanium [3]. The following figure 2.2 and table 2.1 show the properties of some titanium alloys that with values as high as 1600 MPa.

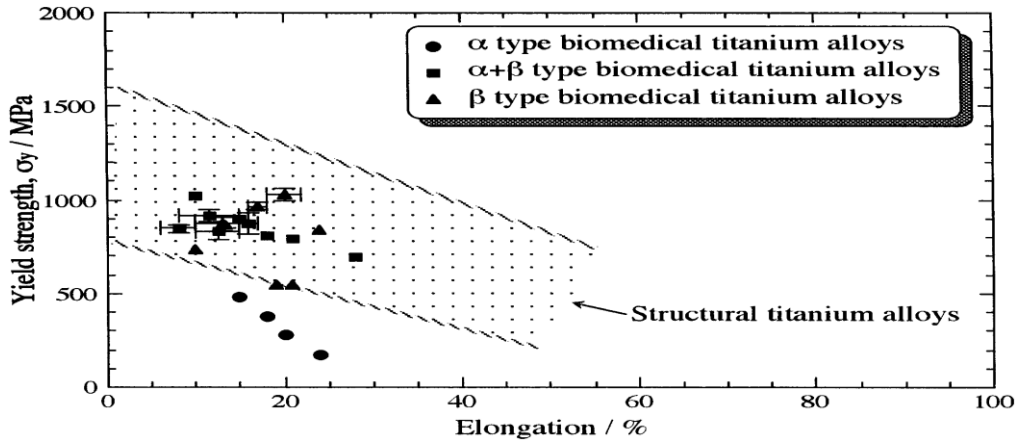

Figure 2.2: Yield strength of titanium alloys, with percentage elongation, retrieved from [3]

Table 2.1: Properties of titanium alloys, retrieved from [3]

Alloy	Tensile strength (UTS) (MPa)	Yield strength (Sy) (MPa)	Elongation (%)	RA (%)	Modulus (GPa)
Pure Ti grade 1	240	170	24	30	102.7
Pure Ti grade 2	345	275	20	30	102.7
Pure Ti grade 3	450	380	18	30	103.4
Pure Ti grade 4	550	485	15	25	104.1
Ti-6Al-4V ELI (mill Annealed)	860-965	795-875	10-15	25-47	101-110
Ti-6Al-4V (annealed)	895-930	825-869	6-10	20-25	110-114
Ti-6Al-7Nb	900-1050	880-950	8.1-15	25-45	114
Ti-5Al-2.5Fe	1020	895	15	35	112
Ti-5Al-1.5B	925-1080	820-930	15-17	36-45	110

The titanium alloys, despite their superior properties to pure titanium, also undergo corrosion and wear due to the environment in the body structure [4]. A rate of chemical reaction and corrosion, however small, still exist in the titanium alloys and identify a threat to functionality of implants, especially in the long term [4].

Treatment of titanium alloys have demonstrated an ability to improve some of the properties of the alloys for use as biomaterials, a concept that can be applied for improvement of the properties of pure titanium. Using ECAE technique to treat UFG Ti-13Nb-Zr alloy, according to Suresh et al. (2012), increases usability of the alloy for implant and is likely to influence corrosion. Effects of the treatment on grain size of the alloy could explain the effects on corrosion that could be inferred on other biomaterials, including the inert pure titanium. The UFG Ti-13Nb-Zr alloy, before treatment, according to results from a study by Suresh, et al. (2012), has an average grain size of 1420 nm for α -alloy and 1620 nm for β -alloy. The ECAE treatment reduces the average grain size by more than 50 per cent, at eight phases, for each type of alloy to indicate a decrease in corrosion due to surface interactions [5].

The treatment, according to the results, reduces corrosion in titanium alloys. The ARB procedure also improves structural and mechanical properties of the Ti-10Zr-5Nb-5Ta alloy. The procedure deforms the degree per layer and reduces the layer thickness of the alloy. It also reduces Young's modulus of the alloy, to 46 GPa (which is close to the Young's modulus of the bone) increases tensile strength, increases hardness, induces an elastoplastic behavior, and lowers corrosion. The effects make the titanium alloy suitable for bone replacement [6].

2.3 Comparative Studies

A treatment of pure titanium, like treatment of titanium alloys, also improves its properties. A treated UFG Ti, using the ECAP method, improves the ability of titanium alloys to integrate into the body and the healing process upon implantation [7]. It increases the average grain size [7], an outcome that is associated with reduced corrosion (Suresh et al., 2012). In addition, the ECAP treatment of pure titanium improves yield strength, tensile strength, and ductility [8]. Table 2.2 shows mechanical properties of pure titanium across phases of the ECAP treatment.

Table 2.2: Properties of CP titanium across phases of the ECAP treatment, retrieved from [8]

Passes (N)	Hv (MPa)	σ_{ys} (MPa)	σ_{UTS} (MPa)	δ (%)	Grain size (μm)
0	1590	275	407	35.0	23
1	2025	520	590	16.1	0.50
2	2100	565	645	15.8	0.35
4	2280	620	655	17.0	0.25
6	2510	690	735	17.4	0.20
8	2640	710	790	19.0	0.20

The temperature of treatment, however, is a significant moderator factor [7]. The equal-channel angular pressing (ECAP) technique also fabricates ultrafine Ti, successfully, and improves biocompatibility and effectiveness of techniques for improving surfaces. ECAP treatment improves other properties like surface texture, wettability, and corrosiveness of electrochemicals [7]. UFG treatment of Titanium has also been associated with improved osseointegration factors such as temperature of deformation and annealing that influence yield and tensile strength of the treated titanium [9]. Severe Plastic Deformation of pure titanium to the fine-grained titanium also develops fibronectin, which aids attachment an implant to body cells, and improves biocompatibility of titanium [10]. Effects of the treatment on the surface of a biomaterial, such as stress and wetness, explain the improved property for use as a biomaterial. Shah, Trobos, Thomsen, and Palmquist (2015), in comparing properties of pure titanium and titanium alloys, following treatment of both materials, identifies equivalence in properties to suggest possible significance of treatment of pure titanium to make it as effective as titanium alloys [11].

Nanostructured Ti semi-products, developed from titanium rods, can also be fabricated using SPD and strain-thermal strategies. The treatment increases the values of “strain effort and deformation resistance” [12] up to at most the eighth pass. The formation of ultrafine-grained (UTF) structure explains the stabilization between the fourth and the eighth pass [12]. At the fourth pass, the formed UTF has a size of between 0.3 and 0.7 μm . The strengthening due to the formation of UTF structure reduces after the second pass due to reduction of ECAP [12]. Other measures for improving properties of biomaterials, towards improved functionality, include compressive residual stresses, coating, and surface nanocrystallization. Effectiveness of ECAP has also been established on other metals, such as stainless steel. The treatment increases tensile strength of the austenitic 316 stainless steel by as much as 1.3 GPa and fatigue limit to about 550 MPa because of the nanostructure that it creates [13].

Treatments of Titanium and its alloys influence its mechanical properties and functionality for use in biomedical applications. Strength, fatigue level, surface characteristics, and deformation resistance are some of the characteristics of titanium that nanostructure influences, and a focus on the torsional property of nano-structured titanium for use in biomedical applications is necessary. Even though titanium alloys have been used because of their superior property to the inert pure titanium, treatment of pure titanium can make improve its functional properties and promote the benefits of its inert state when used for implants. ECAP treatment of the commercial pure titanium, therefore, can improve such properties as the torsional property on which the study focuses.

Chapter 3: System Design

3.1 Design Constraints

3.2 Design Methodology

3.3 Implementation

Chapter 3: System Design

3.1 Design Constraints

In order to achieve the accuracy of the results as intended by this research, we need to strictly follow the engineering standards as they are specified in the American Society for Testing and Materials (ASTM). Other constraints present themselves in the manufacturing, machining, and the economic constraints.

3.1.1 Size Constraint

There are limitations in pure titanium materials. The pure titanium is expensive material and we implement dimensions from [14] so, we can machine the pure titanium. These dimensions according [14] follow ASTM standards

3.1.2 Engineering Standards

Here is a list of engineering standards obtained from ASTM. Those standards will be followed and implemented strictly into our design.

- *ASTM A938 – 07(2013) Standard Test Method for Torsion Testing of Wire*

This standard specifies some conditions for obtaining more accurate results. Those results then shall be more useful in assessing the specimen under torsional loading.

The standard provides specifications for the apparatus that will be used. Also provides specimen preparation, procedure, and how to evaluate the results and the layout presentation of the report.

- *ASTM E4 – 16 Standard Practices for Force Verification of Testing Machines*

This standard is related to the apparatus that we will use. The machine (Compuline Torsion Testing Machine NDW 500) is following the ASTM E4 -16, as well as many other standards. The quality of the apparatus used will help enhance the quality of the results obtained.

The machine will indicate and trace the force in SI units, as indicated in the standard. The machine will be calibrated according to the standard as well.

- *ASTM E83- 16 Standard Practices for Verification and Classification of Extensometer Systems*

This standard is related to the apparatus that we will use. The machine (Compuline Torsion Testing Machine NDW 500) is following the ASTM E83 -16, as well as many other standards. The quality of the apparatus used will help enhance the quality of the results obtained.

The machine will provide Stress-Strain Curve which will comply with this standard. A verification procedure will be done to verify the results prior the real experiment in order to calibrate the machine if needed.

- *ASTM A668/A668M – 16 Standard Specification for Steel Forgings, Carbon, and Alloy, for General Industrial Use*

This standard is related to the apparatus that we will use. The machine (Compuline Torsion Testing Machine NDW 500) is following the ASTM A668/A668M -16, as well as many other standards. The quality of the apparatus used will help enhance the quality of the results obtained.

This standard provides the requirement for untreated and heat-treated carbon steel and alloy steel for general use in the industry. This standard is for different classes of carbon steel and alloy steel.

3.1.3 Sustainability

One of the main constraints of our system design is the sustainability of the results. We are strictly required to have similar results in each experiment in order for the result to be valid. This can be obtained by the proper design of the system, proper choosing of the apparatus.

The results could be affected due to outer reasons such the machine shop that will do the machining of the specimen. We need the specimens to be nearly identical. Another factor is any surface indent or flows resulted from the machining could have high effects on the results, because the torsion test will be affected highly by any surface indents or fracture.

3.1.4 Economic Constraints

One of the major constraints we have is the economical side of the experiment. Titanium itself is a costly material to obtain. Also, the machining of the specimen is difficult due to the strength of the titanium. The machine shops are very limited and not used to titanium as a working metal, which could cost us the specimen itself. Careful preparation is performed in the system design in order to mitigate these errors.

Another economic constraint is the ECAP process that should be used prior the machining and the torsion test. This process is rather costly for the titanium and the specimen produced should be carefully handled in the machining to avoid extra costs.

3.1.5 Manufacturability

Titanium is a strong and a difficult metal to handle. One of the constraints is the machining of the titanium into the exact parameter needed for the test. One of the ways we used to handle this constraint is using a wire cut machine shop. This should provide more accurate results. More accurate than the other machining options.

Wire cut machine shop we found uses 0.5 mm wire to cut through titanium under elevated temperature. This should ensure accurate parameters of the specimen.

3.1.6 Safety

The safety constraints related to our experiment is mostly related to the handling of the machine we will use. We will follow the safety instructions attached in the user manual of the machine.

Another constraint will be the handling of the Nano-Structured titanium, as a poor specimen could have fractures and the Nano parts could be attached to our hands without noticing. These nano particles are reported to toxic to the human body and will be handled with care.

3.1.7 Ethical

As engineers aiming to be professional engineers in the future. We are obligated to follow the code of ethics in all our work. We are obligated to state the accurate results and to clarify any error related to the data or the results. We cannot corner cut to the solutions and we obligated to state the fact if anyone has done so.

3.2 Design Methodology

Titanium is a radioactive substance when bombard by deuterons, and requires careful consideration in its application for medical purposes. For that reason, the only fundamental methods analysis and implementation of the Nano Structured Titanium properties include surface modification (or plastic deformation) and chemicals properties.

3.2.1 Project Architecture Diagram

In this study, the torsional behavior of the Nano-structured titanium substance was investigated with torsion under intense pressure. The investigation was done with relativity test, involving the comparison of the outcome to the coarse-grain substrates. The project architecture is shown in figure 3.1 below.

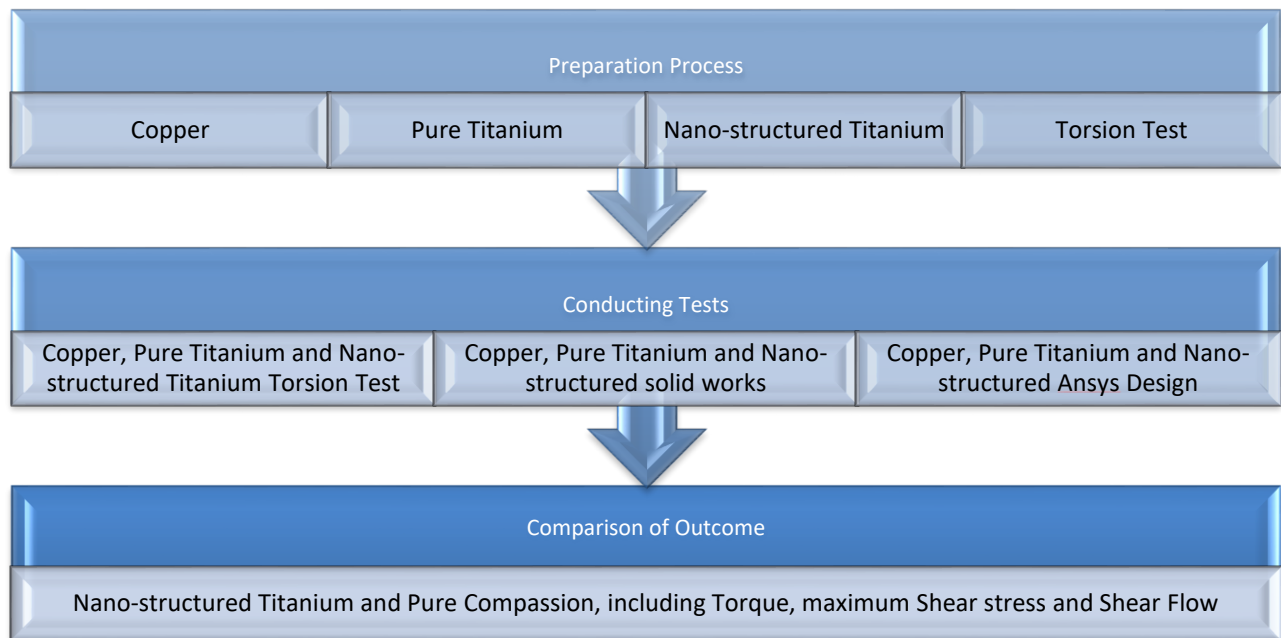

Figure 3.1: Project Architecture Diagram

3.2.1 Preparation:

For all specimens, the measurement for machining will be specified based on the capability of Torsion testing machine. The measurement will be detailed for each specimen.

3.2.1.1 Copper

The design of this specimen involved two designs one them small size and the other is big compared to the small specimen. The purpose of these designs to find out the difference in the torsion test between them and to have hands on the Torsion testing machine NDW 500.

➤ Measurement:

- **Large Specimen**

The Figure 3.2 shows the exhaustive parameters in (mm).

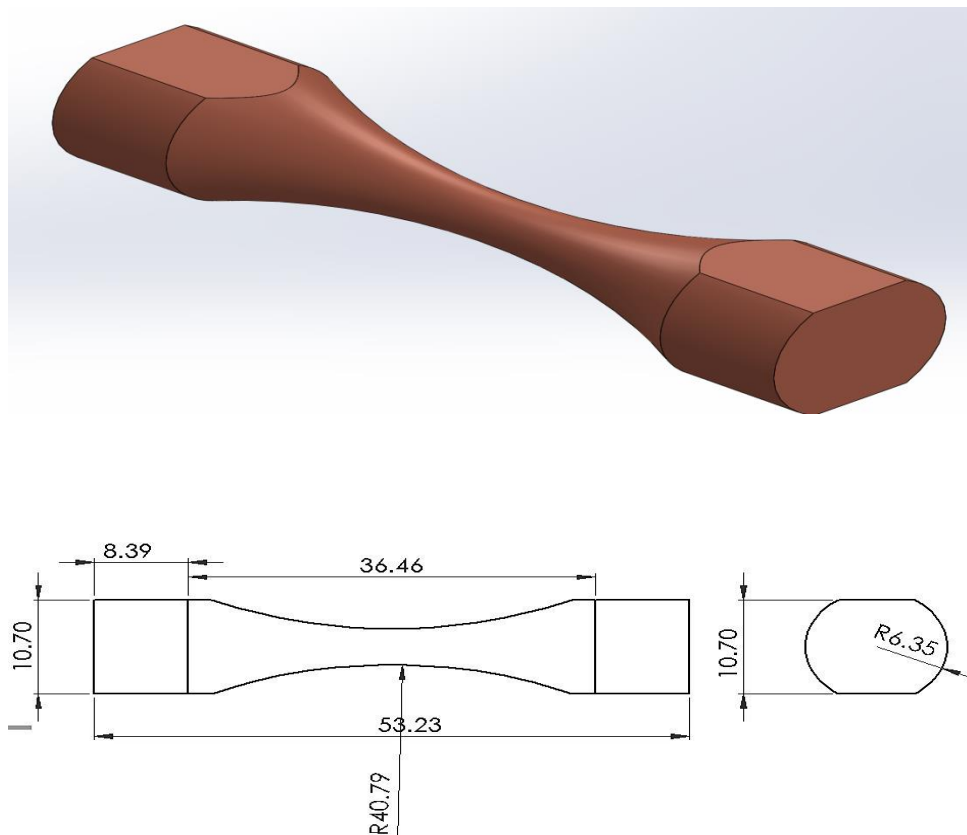

Figure 3.2: Large Specimen Diagram

- **Small Specimen**

The Figure 3.3 shows the exhaustive parameters in (mm).

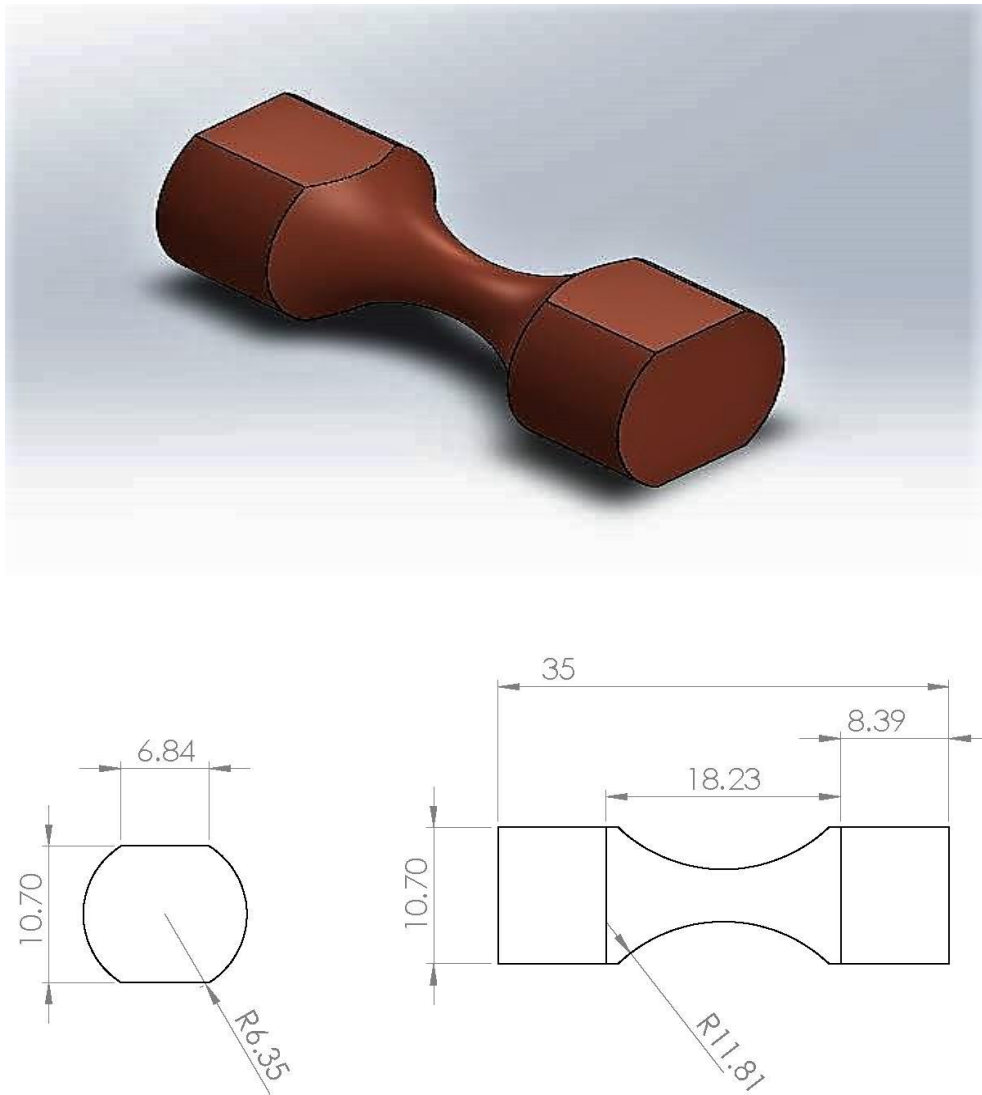

Figure 3.3: Small Specimen Diagram

3.2.1.2 Pure Titanium

Based on the ASTM stander, the process preparation involved surface modification, fine-grained structure for the metallic materials with a wider range of application. It will be designed as the small *Specimen*.

➤ **Measurement:**

The figure 3.4 shows the exhaustive parameters in (mm).

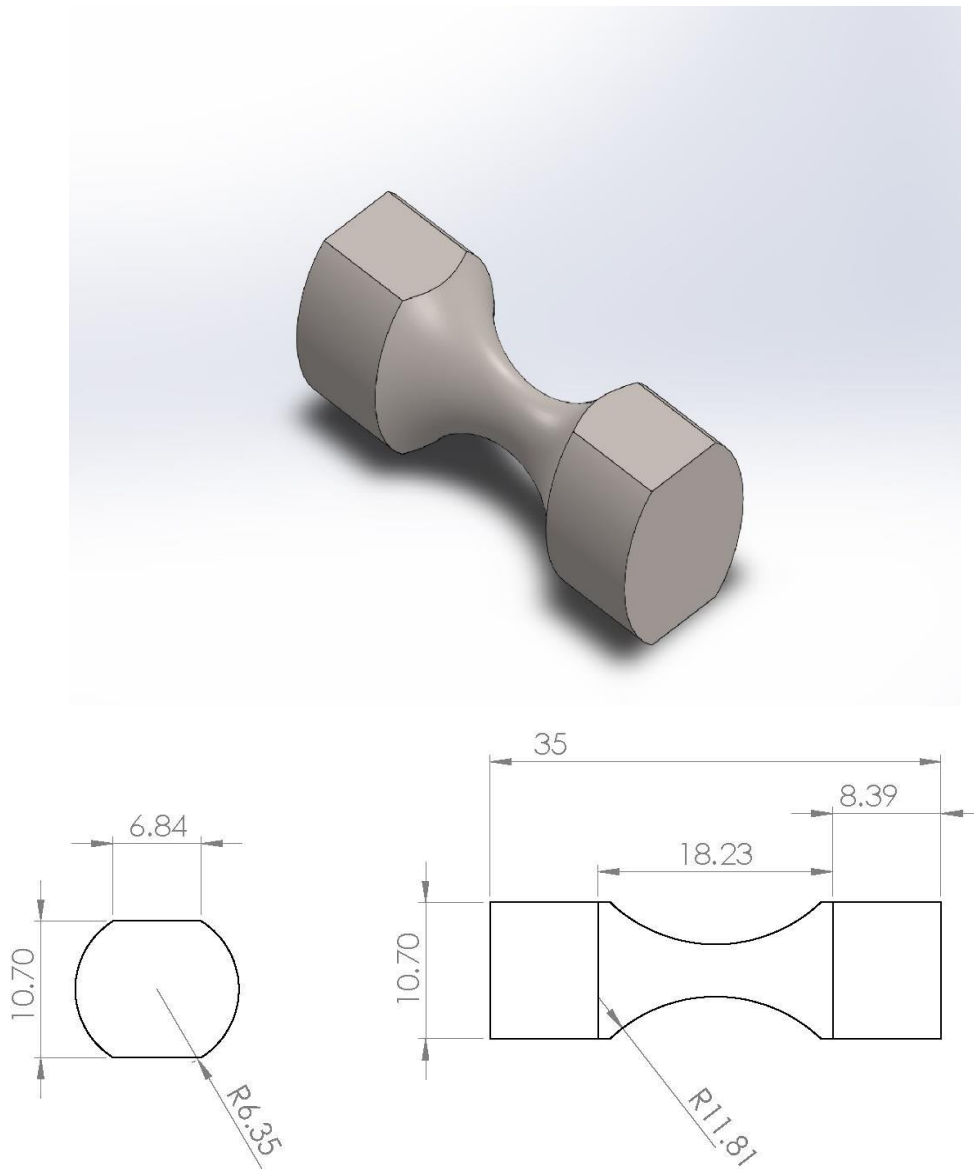

Figure 3.4: Small Specimen Diagram

3.2.1.2.1 Nano Structured Titanium

This involved two steps; the first step is manufacturing of the nanostructured then, the second step is machining the specimen by CNC wire cut. It will be designed as the small *Specimen*.

➤ **measurement**

The figure 3.5 shows the exhaustive parameters in (mm).

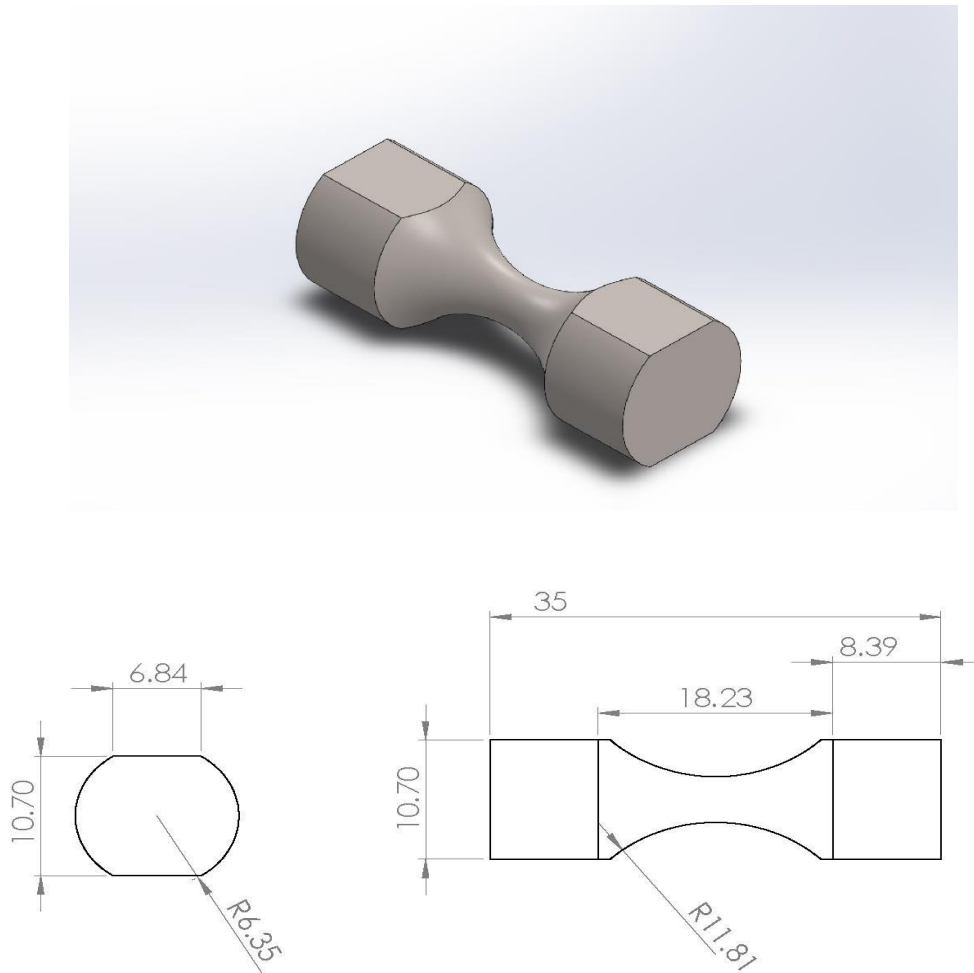

Figure 3.5: Small Specimen Diagram

3.2.2.2 Torsion testing machine NDW 500

The torsion test involved a substantial progress was realized in the fabrication of the products generated from the clean Nano-structured titanium, forming the grade four nanostructured titanium with the optimum tensile strength measuring about 1400MPa and able to withstand fatigue of about 630MPa under a load cycles more than 10^7 cycles shown in figure 3.6 below



Figure 3.6: Torsion testing machine NDW 500

3.2.3 Test

3.2.2.1 Torsion Test

The Torsion Test machine is used for Nano Structured Titanium as well as commercial pure titanium. From the manual, we use only dry wear test. Based on the ASTM, the linear reciprocation with nanostructured specimen indicates the optimal dry-wear resistance for wear speed.

3.2.2.2 Solid Works Program

Solid works program is used to design and analyze the 3 dimensional aspects of the Torsional properties of the Nanostructured Titanium.

3.2.2.3 ANSYS Program

ANSYS program was used for the test simulation and analysis of the heat and pressure transfer in the Nanostructured Titanium.

3.2.3 Result

The result will be comparison between the Nano-structured titanium and pure commercial titanium. The result will include the maximum Torque, Maximum shear stress and Maximum shear flow. However, these results will indicate the plastic deformation in the two tests. Finally, the result will show how is the mechanical forces (wear) and the chemical process will the nanostructured titanium spacemen and its performance in the biomedical application.

3.2.4 Approaches

The focus in the project is test the strength of the nanostructure titanium and the ability to withstand fatigue. These make the nanostructured titanium an ideal material for biomedicine. Apart from the investigation of the physical or the mechanical properties, there was a special reference to the biomedical application of the nanostructured titanium especially in the dental grafts.

3.2.5 Verification of the Design

The nanostructured titanium in the project will improved bio-compatibility, more than the coarse-grained titanium. This is because of the combined mechanical strength and the resistance to chemical corrosion in the enhanced bio-compatible grade of the resultant nanostructured titanium. The Nanostructured titanium is therefore a suitable substance for medical transplants

3.3 Implementation

Our implementation is comparative between two different types of titanium which is Nano structure with different stages of the grain size and commercial pure titanium. In addition, the machining process will be considered on the specimen with our modified dimensions using special machine that is wire machine as per ASTM standards. Then, the testing will be conducted by using torsional testing machine that is provided on our university lap

3.3.1 Torsion test machine

The torsion testing machine is designed such that it is able to undertake tests on non-metal and metal materials, which include components and parts (see figure 3.6). The instrument is also vital in the inspection of material torsion properties in mechanical laboratories of construction,

aviation, industrial, and scientific research departments. The machine for testing embraces a PC-Controlled servo system, which is loaded via the active cartridge rotation as driven by a reducing and servo motor. The torsion angle and torque are determined using a photoelectric encoder and high-precision torque transducer. These tests are all operated and controlled using a computer software that dynamically displays, processes, collects, stores and prints out the curves of the torsion test, peak values, and loading rates.

The machine has main features as the data processing system, torsion and torque angle determination system, the servo loading system and a unit for the platform operation. The entire control mode and test process in all stages are presented to customers in accordance to the requirements of the tests. The control system of the PC helps in establishing a control arithmetic, which automates the entire test. Pure Titanium with different passes and this one of the specimens after test as the Figure 3.7 below



Figure 3.7: The specimen after the Torsion Test.

3.3.2 ECAP Process

Metals processing using the equal-channel angular pressing (ECAP) relates to the procedure where the billet is pressed using a constrained die that exists in a bent channel having an abrupt angle. ECAP processing is very attractive since it results in the refinement of the grain in a sub micrometer range while introducing superior mechanical properties that includes high strength.

Ti processing while using ECAP is a complex procedure since it involves the occurrence of segmentation and cracking. Past experiments indicated that it was impossible to have the CP processed at Ti in the room temperature while utilizing the conventional ECAP die at 90 degrees. Of late, regular segmentation and damage development on longitudinal axes where the processing occurs through ECAP is demonstrated in an effective manner with the use of the finite element modeling (see figure 3.8).

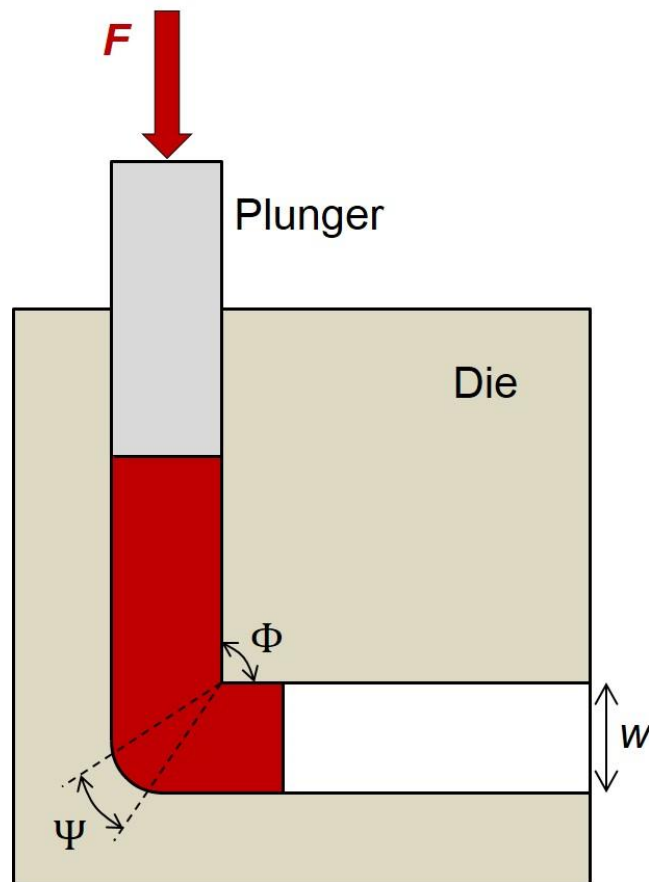

Figure 3.8: Schematic presentation of the ECAP process

In bulk metals, ECAP process is often utilized as a means of inducing great grain refinement. However, such a process is complex in some of the materials. Examples of these materials are

the ones that have hexagonal close-packed metals consisting of limited independent slip systems. Intensive finite element calculations have indicated that ECAP die could be used in the processing of alloys that are “difficult-to-work” with an increment in the channel angle. The approach is also illustrated using the two-phase Mg- 8% Li alloy where the pressing of the alloy could occur without any cracking being undertaken using a single pass that occurs at the room temperature where the angular angle is 90 degrees.

There is a lot of interest on titanium since it depicts great biocompatibility, which offers a significant potential for being used in the dental implant materials. In the implants, the ECAP processing occurs via the CP Ti in four passes subjected to 723 K. however, using ECAP in processing CP Ti helps in improving the simplicity of the experiment, as well as gaining a high speed on the same. In practice, the situation is complex because there is lack of adequate information on the description of the microstructural traits and CP Ti mechanical properties when processing occurs through ECAP in the room temperature. The figure 3.9 below shows the die after one pass.

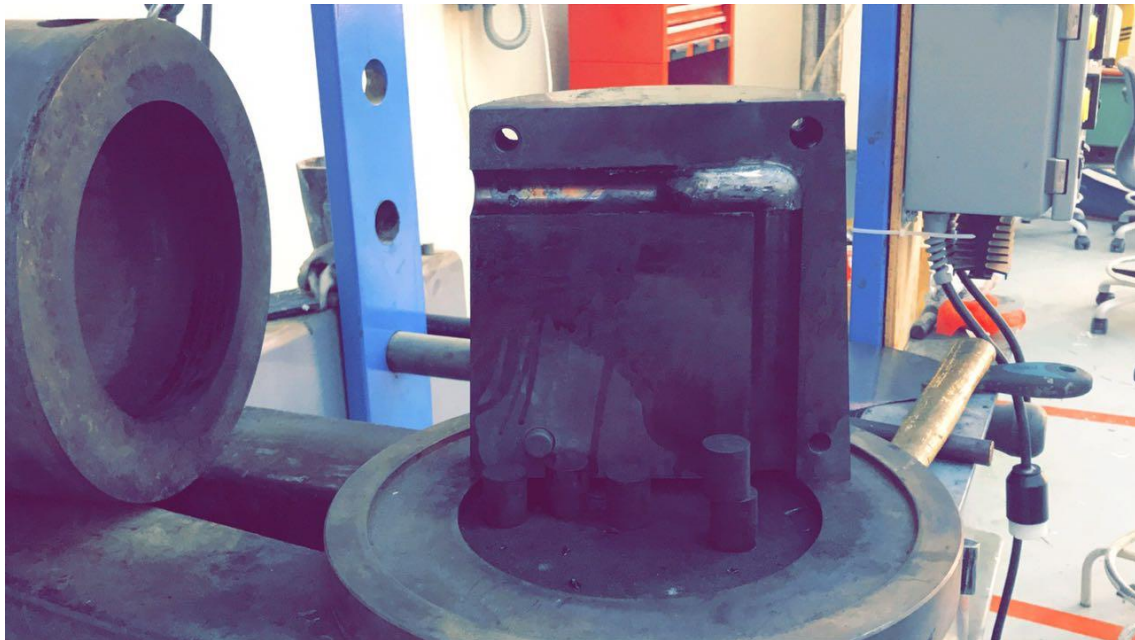

Figure 3.9 Die ECAP Process after one pass

3.3.2.1 Preparation for ECAP Process

For ECAP process Titanium sample, die, and plunger need procedure before begin the process. The die and the plunger are steel H 13 with heat treatment. Titanium sample preformed on it annealing to equalizing the grains. The specimen heated up to 324 C for distribute the stresses all over grains.

3.3.3 Machining

3.3.3.1 Copper Specimens

3.3.3.1.1 Purpose of machining Copper

The purpose of machining Copper was to determine if there is any size effect. Because there is a limitation in Titanium materiel and we could not use the regular dimensions as in the specimen for Torsion test device. Therefore, we used other dimensions according to ASMT for Torsion Testing from [14]. We bought 300 mm length and circler base with 16 mm dimeter Copper from Khusheim Company for Industrial Equipment as in the figure 3.10 below.



Figure 3.10: 300 mm length and circler base with 16 mm diameter Copper

3.3.3.1.2 Products

To determine the size effect, we machined the copper piece in figure 3.8 in Modern Precision Engineering workshop. Therefore, we produced two specimens 36 mm and 120 mm by CNC Lathe Machine and CNC Milling Machine as in figure 3.11 below.



Figure 3.11: Two Specimen with 53.23 mm and 36 mm length for torsion test

3.3.3.1.3 CNC Lathe Machine

We used CNC lathe machine to get precise and accurate dimensions to get reliable results. However, the dimensions was in millimeters and that why we used CNC lathe machine as in figure 3.12 below.



Figure 3.12: CNC Lathe Machine

3.3.3.1.4 CNC Milling Machine

We used CNC milling machine to cut the holding ends of the specimens so, in the torsion test the specimen will not slip. We used CNC milling machine as in figure 3.13 below to be accurate and precise cuts.



Figure 3.13: CNC Milling Machine

3.3.3.2 Titanium Specimens

3.3.3.2.1 Purpose of machining titanium

The purpose of machining titanium was to prepare valid specimen for the torsion test. For comparing the torsional property of the Microstructure Pure Titanium with Nano Structure Pure Titanium. The Nano structure Titanium material produced by ECAP process. We will have three different stages in pure titanium. One microstructure while the other two with Nanostructure. The different between the two Nanostructure titanium is the number of passes through the ECAP process. This comparison is the main objective of our project, which will clarified the importance of the Nano structure Pure Titanium in the biomedical material. Figure 3.14, 3.15 show the materiel after ECAP process.



Figure 3.14: 2 passes Nanostructure Titanium with scale



Figure 3.15: 4 passes Nanostructure Titanium 50 mm length, 22 mm Diameter

3.3.3.2.2 Products

To determine the size effect, we machined the titanium piece which was harder than the copper and of course it needed more power to get it in the shape that we want, and finally we got a one microstructure also a Nano structure with 2 passes and 4 passes Nanostructure. ALL the products of the machining have same appearance from the outside as in figure 3.16, for that we differ between them by number of dots as in figure 3.17 also in figure 3.18 shows the scale of them.



Figure 3.16: Microstructure Pure Titanium Specimen 36 mm

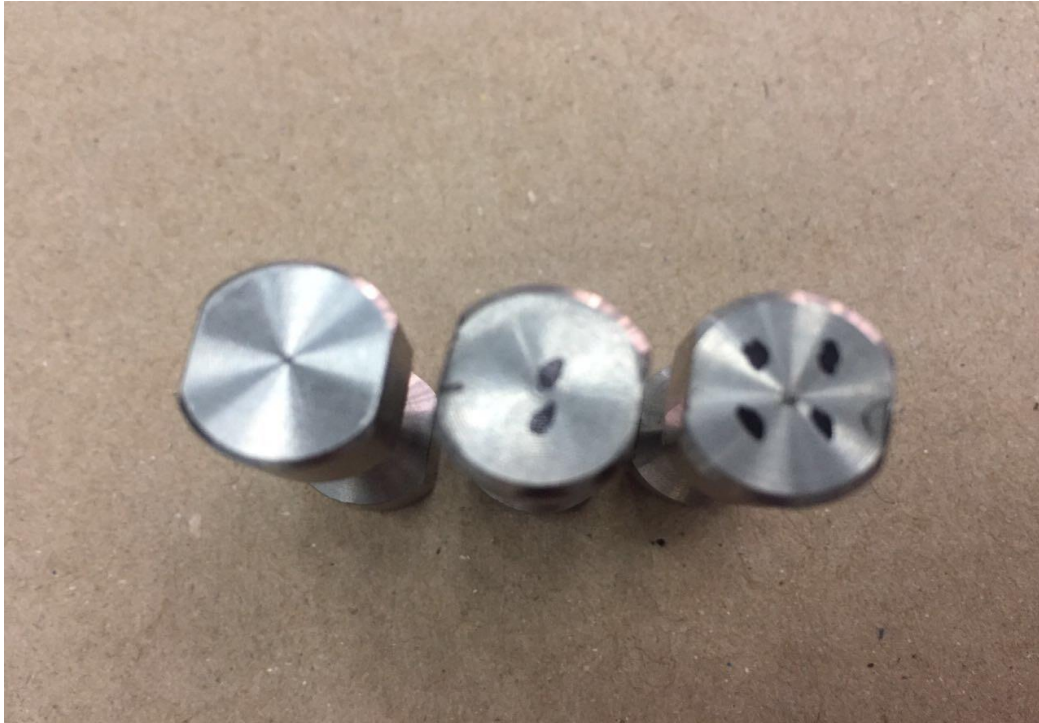

Figure 3.17: Pure Titanium Specimens with different stages



Figure 3.18: Titanium specimens with different stages scale

3.3.3.2.3 CNC Lathe Machine

We used CNC lathe machine to get precise and accurate dimensions to get reliable results. However, the dimensions was in millimeters and that why we used CNC lathe machine as in figure 3.10. Same process as in Cooper Specimens

3.3.3.2.4 CNC Milling Machine

We used CNC milling machine to cut the holding ends of the specimens so, in the torsion test the specimen will not slip. We used CNC milling machine as in figure 3.11 to be accurate and precise cuts. Same process as in Cooper Specimens.

Chapter 4: System Testing and Analysis

4.1 ECAP (Equal Channel Angular Pressing) Process

4.2 Machining

4.3 Experimental Torsion Test

4.4 Simulating the Torsion Test using ANSYS and SolidWorks

Chapter 4: System Testing and Analysis

In this chapter we will present the results from each component from the system design chapter, analyze, and go through the discussion of those results. This chapter will show the Nano-structured titanium resulted from the ECAP process. It will show the machining of the specimens. Then the torsion testing, and finally the simulation to verify the testing results.

4.1 ECAP (Equal Channel Angular Pressing) Process

The ECAP process was the method used to produce the Nano-structured titanium in this experiment.

4.1.1 Preparation

We obtained a cylindrical, 22mm in diameter, commercial pure titanium and we subjected it to annealing to uniform the structure of the material. The ECAP die is then heated for 24 hours to reach around 320 degree Celsius. This will increase the ductility of the pure titanium so that it doesn't have cracks or defects when pressed through the channel. It will also reduce the pressure required to perform the process.

We also prepared a cylindrical, with the same 22mm diameter, H13 steel rods to use them to transfer the pressure to the titanium rod inside the ECAP die. The H13 steel was used because of its known hardness, toughness, and high resistance to thermal fatigue cracking. Figure 3.9 shows the ECAP die and the channel inside:

4.1.2 The ECAP and the results

The ECAP die we used had a 90 degree angular channel. We used lubricants to avoid scratches to the surface of the titanium when start applying pressure. The pressure applied to push the titanium through the channel was varying but never exceeded 100 bar. The product is then left to cool in ambient temperature to avoid hardening the surface. This process is repeated 2, and 4 times to obtain the 2-pass Nano-structured titanium and the 4-pass Nano-structured titanium rods, respectively. The obtained rods from the ECAP process are shown in figures 3.14 and 3.15

4.2 Machining

We machined the rods obtained from the ECAP process, using dimensions specified in system design chapter.

4.2.1 Preparing the specimens

We prepared the specimens using CNC Lathe Machine and CNC Milling Machine. We used CNC lathe machine for its accuracy in dimensions in order to get reliable results. The CNC milling machine was used to cut the holding ends in a way that it does not slip in the torsion machine when performing the test.

4.2.2 Machined parts

We prepared 2 copper specimens with different dimensions as specified in system design chapter. This was to study the size effect on the results. We also machined 3 other titanium specimens, one pure titanium, 2 pass nano-structured titanium, and 4 pass nano-structured titanium. Since the look of the microstructure and nanostructure titanium specimens are very similar, we will present only one figure to show the specimen shape.

In order to differentiate the 3 titanium specimens before and after the test, we draw dots on top of the specimens to represent the number of passes. Figures 3.11, 3.16, and 3.17 shows the copper specimens, titanium specimen, and the differentiation dot method, respectively.

4.3 Experimental Torsion Test

COMPULINE Torsion Testing Machine NDW 500 was used to perform the tests in this experiment. Before we perform the experiment on titanium specimens, we tested two Copper specimens differ in size in order to determine if there is a size effect in this experiment.

4.3.1 Size effect on Copper specimens

4.3.1.1 Experimental data comparison

We compared the data obtained from the Torsion Machine in terms of maximum torque applied until fracture, maximum shear stress, and shear stress at yield point. The comparison results are shown in figures 4.1, 4.2, and 4.3 respectively.

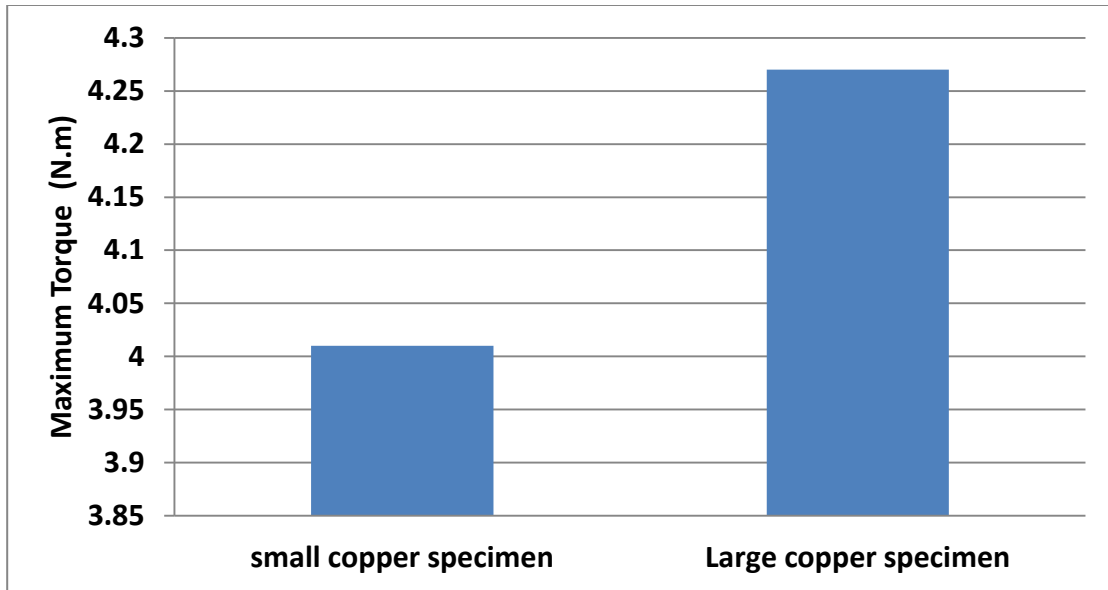

Figure 4.1: Comparison of maximum torque until fracture

The figure 4.1 shows the comparison of maximum torque until fracture of the small and large copper specimens. The figure shows the maximum torque in N.m. The figure shows a difference of approximately 0.26 N.m in the favor of the large specimen.

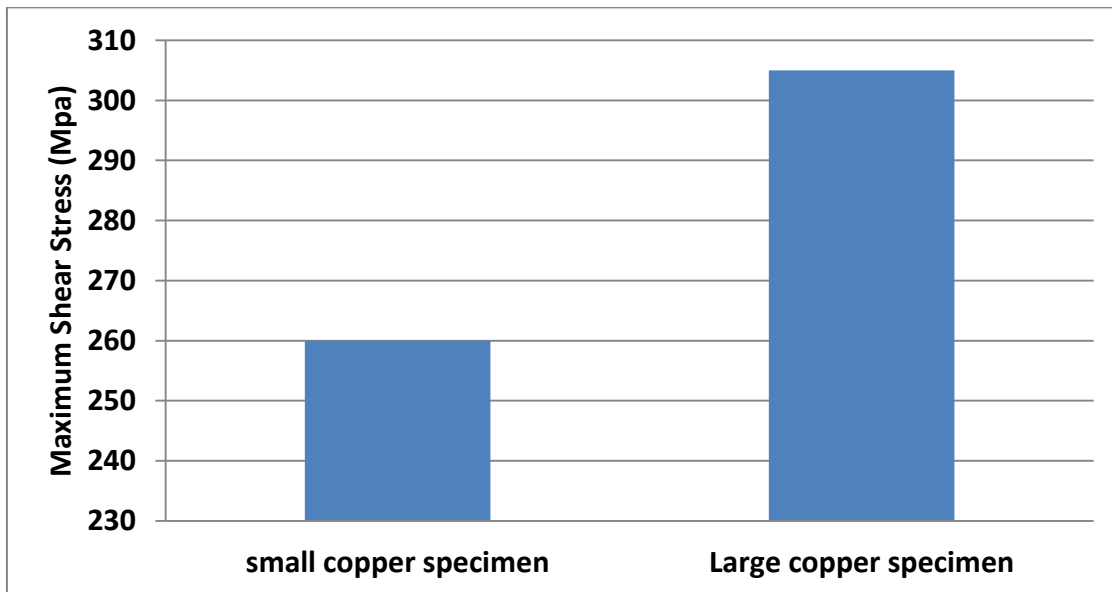

Figure 4.2: Comparison of maximum shear stress

The figure 4.2 shows the comparison of maximum shear stresses of the small and large copper specimens. The figure shows the shear stress in MPa. The figure shows a difference of approximately 45 MPa in the favor of the large specimen.

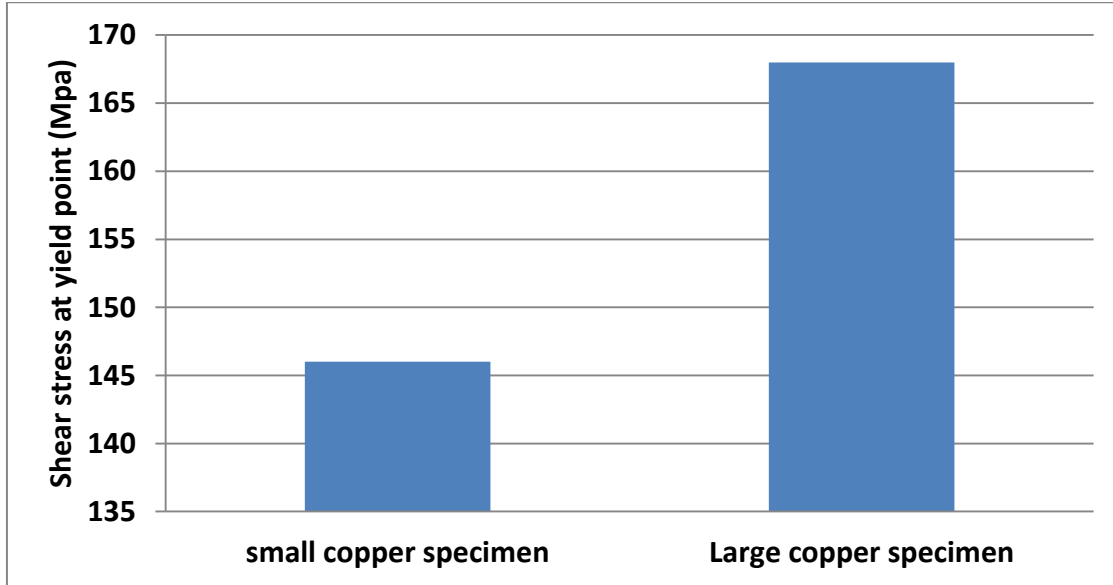

Figure 4.3: Comparison of shear stress at yield point

The figure 4.3 shows the comparison of shear stresses at yield point for the small and large copper specimens. The figure shows the shear stress in MPa. The figure shows a difference of approximately 22 MPa in the favor of the large specimen.

4.3.1.2 Discussion on size effect test results

There was a slight difference in the cross sectional area between the two specimens (0.13 mm). This difference is due to the curved shape of the specimens (Figure 3.15). This is due to the medium accuracy CNC machine that was used to make the specimens.

The two specimens were of length of 36mm and 53.23 mm. Both specimens have similar cross section area throughout. The variation of the results obtained, especially in terms of maximum shear stress and shear stress at yield point, show that there is a size effect in the experiment. The numerical values are shown in appendix C.

4.3.2 Analysis of experimental data for titanium specimens before comparison

During the torsion test of the 4 passes titanium specimen, a slippage occurred in the torsion machine grips. The stress-strain curve was affected. Since we seek integrity in the information presented, we will roll out some of the data and show the reason for considering those data to be not valid.

4.3.2.1 Stress-strain curves for a valid test and the test with the slippage

NDW 500 torsion machine provides data in the form of curves, with numerical values for only few main points. Stress-strain curve for a normal torsion test is shown in the following figure 4.4

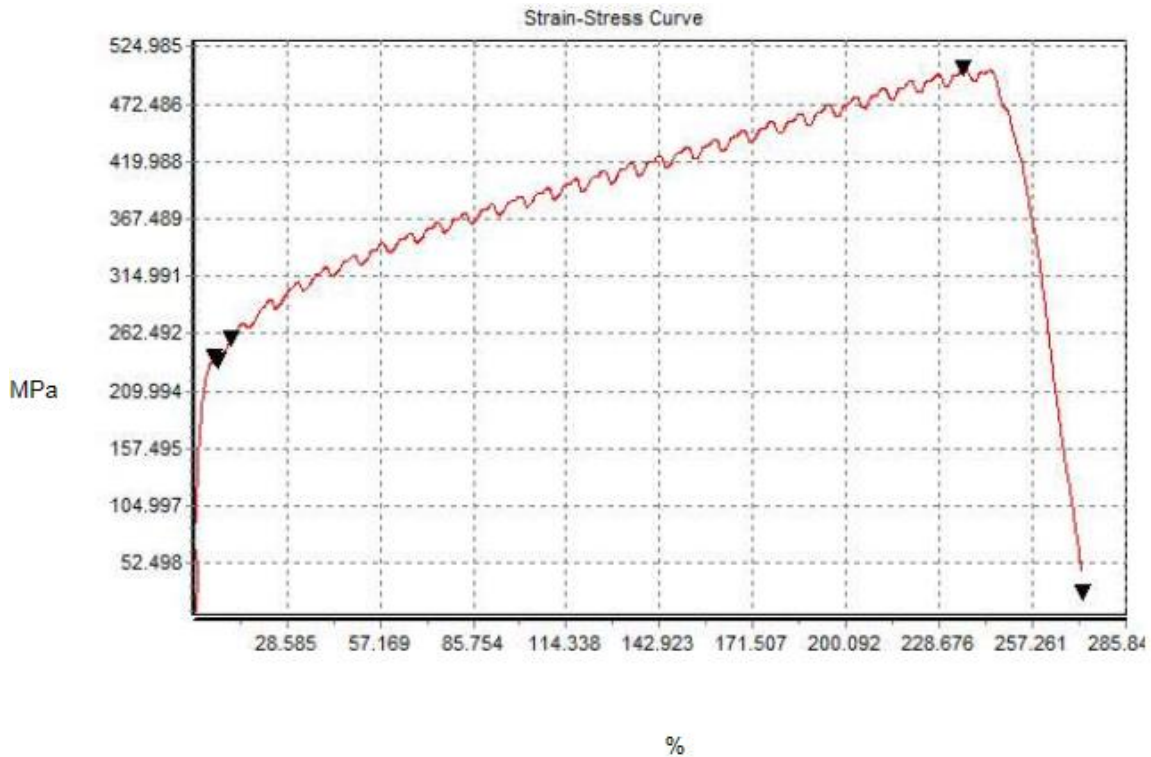

Figure 4.4: Stress-strain curve for a normal torsion test

The figure 4.4 shows the stress-strain curve for a normal torsion test for titanium specimen. The figure shows the shear stress in MPa, while the strain is presented in terms of percent elongation. The black triangle shape points are pointing towards the main points in the curve. From left to right, they are yield point, proportionality point, maximum shear stress point and maximum strain point. Next figure 4.5 shows the torsion test with the slippage.

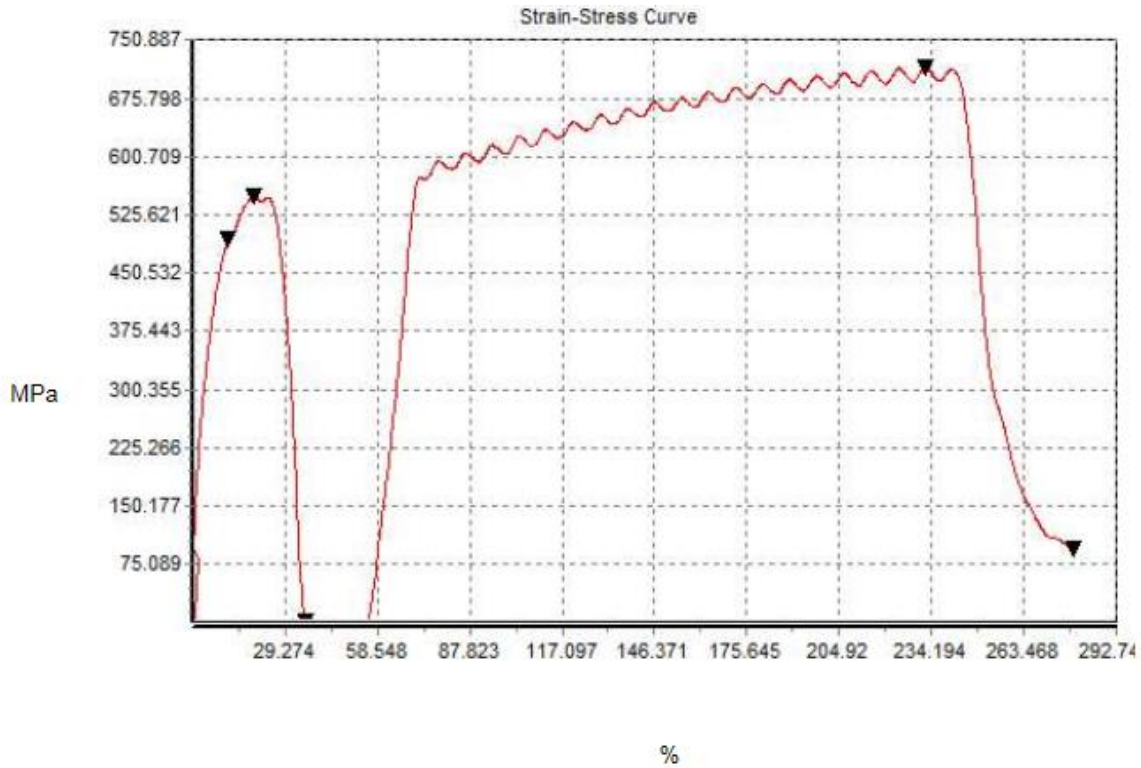

Figure 4.5: Stress-strain curve for the torsion test with the slippage for the 4 passes Nano-structured titanium specimen.

The figure 4.5 shows the stress-strain curve for the torsion test with the slippage for the 4 passes Nano-structured titanium specimen. The figure shows the shear stress in MPa, while the strain is presented in terms of percent elongation. The black triangle shape points are pointing towards the main points in the curve as explained in the previous figure 4.4.

4.3.2.2 Data validation analysis

The slippage occurred near the yield and proportionality points on the curve. The numerical values were clearly affected. Both points were rolled out of the comparison due to their unreasonable values.

The rotation angle was also affected as well as the percentage of elongation. The numerical values were not consistent with other specimens values. Both were rolled out from the comparison. The maximum torque and shear stress were slightly affected from the slippage and they will be presented in the comparison due to their reasonable and consistent values (see appendix C).

4.3.3 Titanium torsion test data comparison

In this section, we will compare the three titanium specimens (Cp-ti, 2 passes nano-structured pure titanium, and 4 passes nano-structured pure titanium) in terms of maximum torque, rotation until fracture, maximum shear stress, shear stress at yield point, and shear stress at proportionality point. For the 4 passes nano-structured pure titanium specimen, we will use only the valid data as explained in the previous section.

4.3.3.1 Comparing maximum torque until fracture

The maximum torque data resulted from the torsion test of the three titanium specimens are presented in the following figure 4.6.

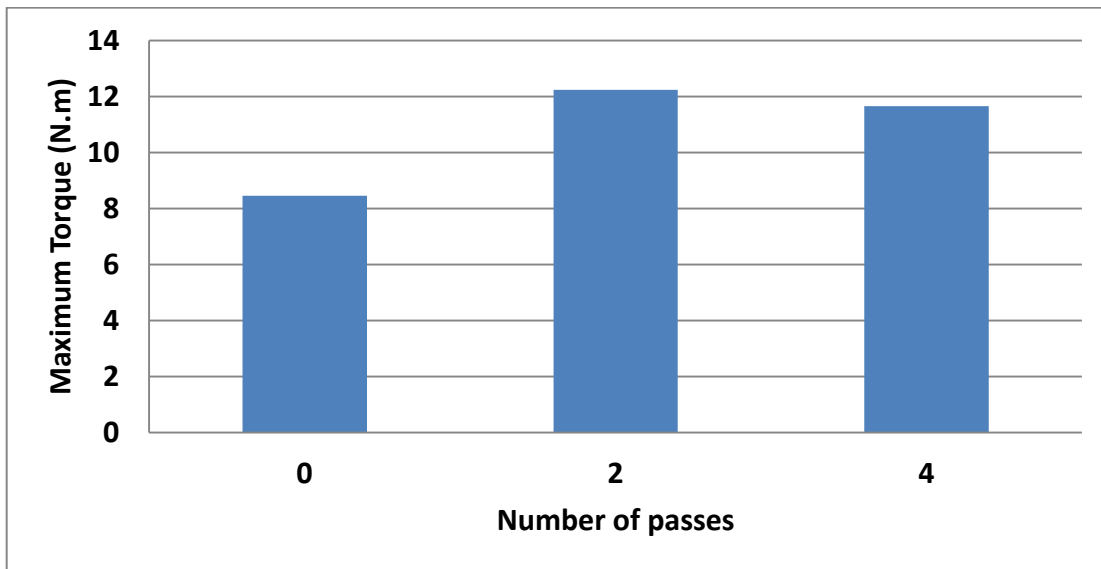

Figure 4.6: Comparison of maximum torque between the three titanium specimens

The figure 4.6 shows the comparison of maximum torque between the three titanium specimens. The vertical axis shows the maximum torque in N.m, while the horizontal axis shows the number of passes in the ECAP die. Zero passes represent the micro-structure pure titanium specimen.

The maximum torque of the micro-structure pure titanium was 8.45 N.m. This number has increased after two passes reaching 12.24 N.m. The maximum torque remained almost the same after the fourth pass in the value of 11.65 N.m. (see appendix C).

4.3.3.2 Comparing rotation angles until fracture

Rotation angles resulted from the torsion test of the two titanium specimens are presented in the following figure 4.6.

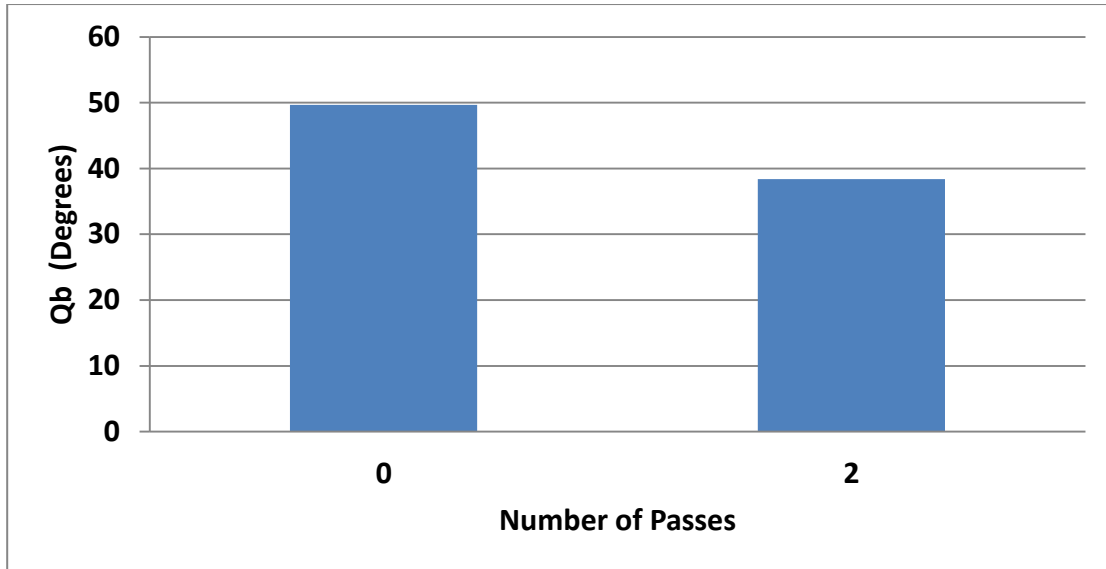

Figure 4.6: Comparison of rotation angles between the two titanium specimens

The figure 4.6 shows the comparison of rotation angles between the two titanium specimens. The vertical axis shows degrees of rotation, while the horizontal axis shows the number of passes in the ECAP die. Zero passes represent the micro-structure pure titanium specimen.

The micro-structure pure titanium rotated for 49.68 degrees before fracture. The angle of rotation decreased after two passes to 38.39 degrees for the Nano-structured pure titanium. This shows that the micro-structured pure titanium is more ductile than the nano-structured pure titanium after two passes in the ECAP die. (see appendix C).

4.3.3.3 Comparing maximum shear stress

The maximum shear stress data resulted from the torsion test of the three titanium specimens are presented in the following figure 4.7.

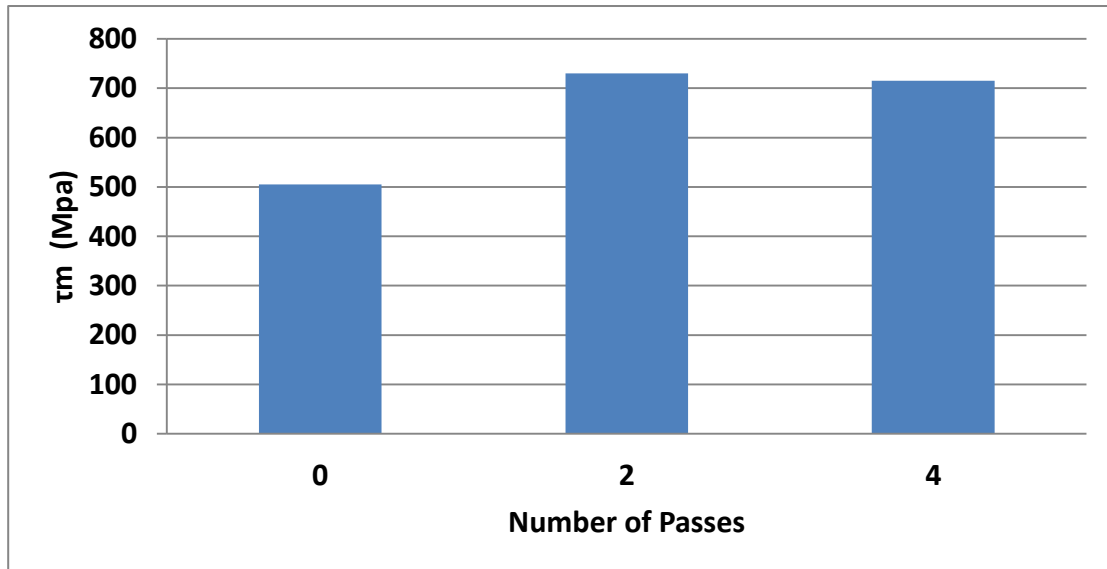

Figure 4.7: Comparison of maximum shear stress between the three titanium specimens

The figure 4.7 shows the comparison of maximum shear stress between the three titanium specimens. The vertical axis shows the maximum shear stress in MPa, while the horizontal axis shows the number of passes in the ECAP die. Zero passes represent the micro-structure pure titanium specimen.

The maximum shear stress of the micro-structure pure titanium was 505 MPa. This number has increased after two passes reaching 730 MPa. The maximum shear stress remained almost the same after the fourth pass in the value of 716 MPa. (see appendix C).

4.3.3.4 Comparing shear stress at yield point

The shear stress at yield point data resulted from the torsion test of the two titanium specimens are presented in the following figure 4.7.

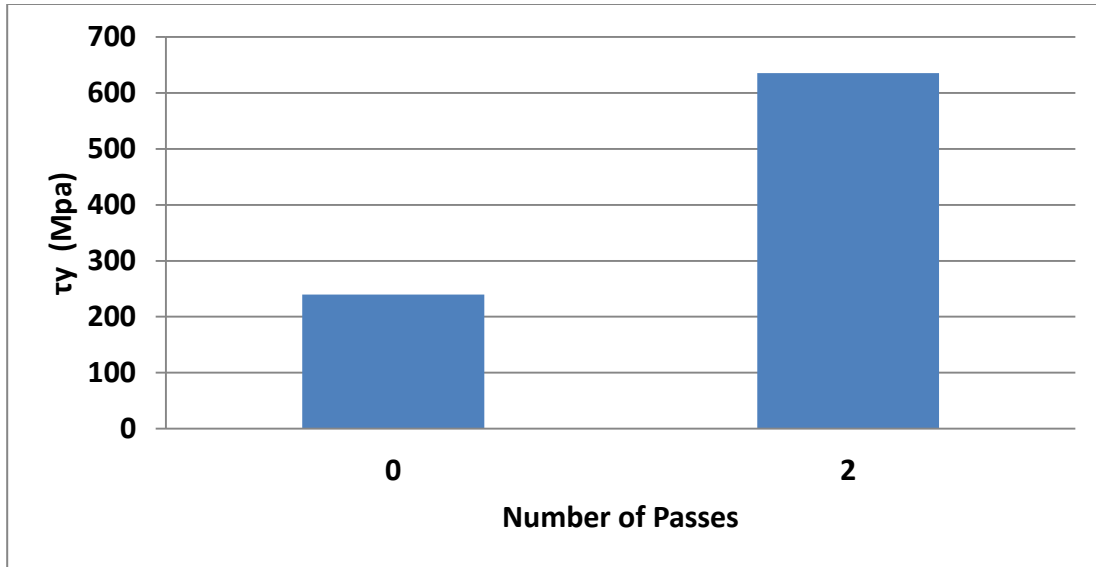

Figure 4.7: Comparison of shear stress at yield point between the two titanium specimens

The figure 4.7 shows the comparison of shear stress at yield point between the two titanium specimens. The vertical axis shows shear stress values in MPa, while the horizontal axis shows the number of passes in the ECAP die. Zero passes represent the micro-structure pure titanium specimen.

The shear stress at yield point for the micro-structure pure titanium was 240 Mpa. This number has increased significantly after two passes reaching 635 MPa. This shows the effect of ECAP process on the yield point of the pure titanium.

4.3.3.5 Comparing shear stress at proportionality point

The shear stress at proportionality point data resulted from the torsion test of the two titanium specimens are presented in the following figure 4.8.

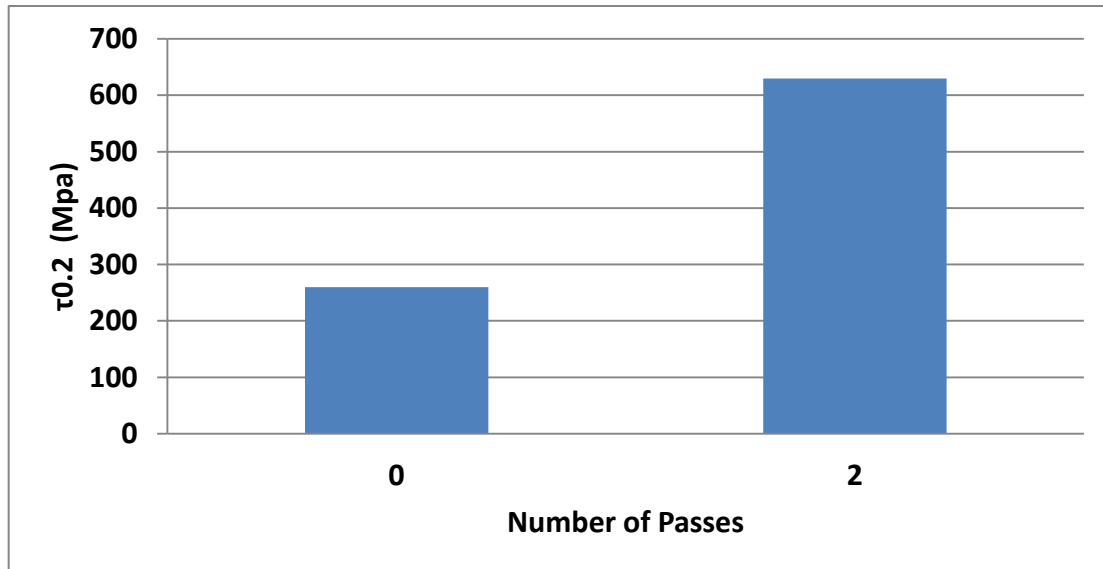

Figure 4.8: Comparison of shear stress at proportionality point between the two titanium specimens

The figure 4.8 shows the comparison of shear stress at proportionality point between the two titanium specimens. The vertical axis shows shear stress values in MPa, while the horizontal axis shows the number of passes in the ECAP die. Zero passes represent the micro-structure pure titanium specimen.

The shear stress at proportionality point for the micro-structure pure titanium was 260 MPa. This number has increased significantly after two passes reaching 630 MPa. This shows the effect of ECAP process on the proportionality point of the pure titanium.

4.3.4 Discussion and findings

The results show that the properties of the Nano-structured titanium are different from the properties of the original pure titanium. The ECAP process enhanced the mechanical properties of the pure titanium. All of the comparison parameters were increasing toward more strength and less ductility as we increased the number of passes in the ECAP die.

The maximum torque that the nano-structured specimen can withstand before fracture increased by exactly 3.79 N.m. This represents a 44.85% increase in the torque taken before fracture.

The rotation angle that the original pure can withstand decreased after two passes in the ECAP die. The difference was 11.3 degree between the two specimens. This represents a 62.4% decrease in the rotation angle before fracture. This is understood because we know that the pure titanium is soft. Performing ECAP process on the pure titanium has decreased the ductility of the original material. The new ductility does not present any threats to the properties required for the medical application. The ductility needed for such application does not exceed 10% ductility at maximum.

The yield shear stress and proportionality point shear stress both received a huge increase after the first two passes. The difference in yield shear stress between the original material and after the ECAP process reached 395 MPa. This represents a 165% increase in the yield shear stress. This shows the enhancement in the strength of the titanium after two passes. A similar effect happened with the shear stress at proportionality point. The difference after two passes reached 370 MPa. This represents a 142% increase. These results show the huge effect of the ECAP process on the strength of the pure titanium.

We can conclude that ECAP process enhances the strength of the pure titanium, especially near the yield point. It also lowers the ductility of the pure titanium. These results can be obtained after only two passes in the ECAP die. When we increase the number of passes the change in the strength of the titanium becomes smaller. This is due to the fact that the nano-structured grains are started to form after the first pass and the material already gained the strength effect. Increasing the number of passes will only solidify the grains and make them thermodynamically more stable than the material with only two passes.

4.4 Simulating the Torsion Test using ANSYS and SolidWorks

Program's simulations are used to verify experimental results. In this experiment, we will use Ansys program as F.E.M. in order to check the results from the torsion machine. However, mesh sensitivity needs to be determined before starting the simulation analysis. To determine the mesh sensitivity, we will use SolidWorks modeling.

4.4.1 Introduction to F.E.M

4.4.1.1 FEM theory

This is a numerical procedure for obtaining solutions to a problem with boundary values. The principle behind this is to replace an entire continuous domain by a number of sub domains in which the unknown functions may be presented by some kind of simple interpolation function with some unknown coefficient [15]. It involve four major steps:-

1. The domain subdivision
2. The selection of interpolation function
3. Equation formulation for the system
4. Solving the system equation

4.4.1.2 Description of the torsion test in SolidWorks

Ensure that material are well set, then you can right click on the study or what is known as beam then move to material, here you can load materials from the cloud. From the results, the materials did not fail but is having high deflection [16].

4.4.1.3 The mesh refinement Process

A good finite element analyst should start with the understanding of the physics of the system that is to be analyzed before the description could be completed. Use a relatively fine discretization in the region where the analyst expects a high or low gradient of the strain or stress. Some of the region to watch in the gradient include near entrant corners or the sharply curved edges. The area in the vicinity of concentrated loads, concentrated reactions, cracks and

cutouts. The area in the interior of structures with the abrupt changes in the thickness, material characteristics or cross sectional areas.

Factors which determines the quality of the mesh include rate of convergence, solution precision and CPU time required. In the two dimensions, coarse and fine are powerful tools for adapting a poor mesh into good mesh. This will help in improving the quality of mesh.

4.4.1.4 Assumptions

1. One of the assumptions is that the shaft is perfectly straight
2. The shear stress induced in shaft should not exceed the elastic limit
3. The twist along the shafts is assumed to be uniform
4. It is assumed that twisting has no effect on circularity of the shaft

4.4.2 Mesh Sensitivity Measurement

Mesh sensitivity is a method used to find the largest element size that is adequate to find accurate results from the simulation programs. The figure 4.9 below shows the mesh sensitivity curve.

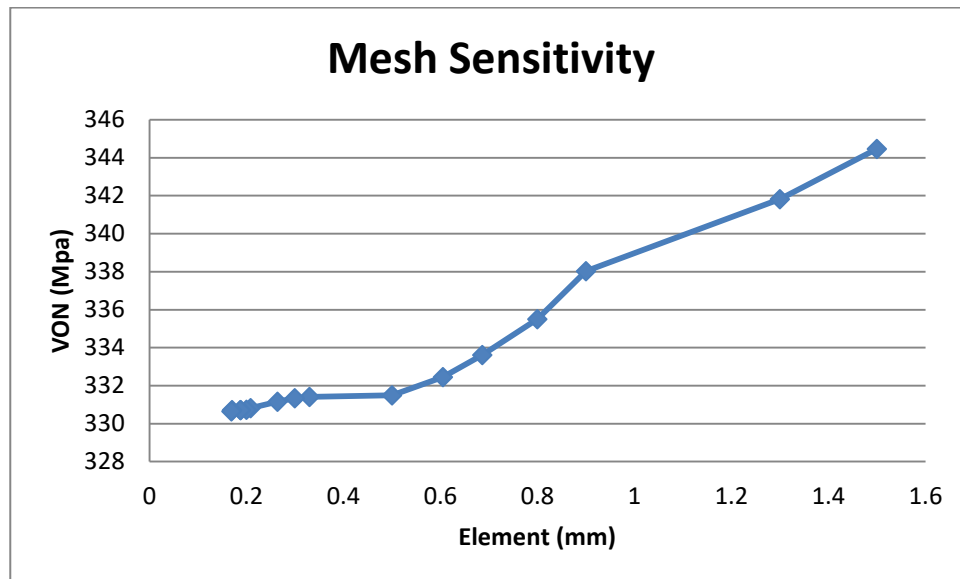

Figure 4.9: Mesh sensitivity analysis obtained from SolidWorks F.E.M.

The figure 4.9 shows the mesh sensitivity analysis from SolidWorks F.E.M.. The graph uses Von Mises failure theories to determine the stresses in MPa, while the mesh element size is measured in millimeters.

We see from the figure that at 1.6mm element size, the stress results is 15 MPa off the accurate value. This number starts to decrease as we decrease the element size. The largest possible element size that does not affect the accuracy of the analysis is at 0.2 mm. At values smaller than that, the stress values remain the same with negligible differences.

4.4.3 Verification of the F.E.M. with experimental results

F.E.M. was used to verify the experimental results. ANSYS program was used for simulating the torsion test with the same boundary conditions, while SolidWork was used to make the part module and also to determine the appropriate mesh size.

4.4.3.1 Simulation type and specifications

The properties used for the material in the simulation was for Grade 1 pure titanium (appendix D). The module analysis in the program was static structural. The mesh size used was 0.2mm as the one we established in the previous section in order to get the proper accuracy. We selected 19 different values for torque in order to draw the stress strain curve to compare with the experimental results. The torque values in the program were in N.mm. Starting from 500 N.mm and going up to 9000 N.mm with 500 N.mm as incremental value. See appendix X for more details.

4.4.3.2 Results and comparison

The results obtained for shear stress values at critical points were more or less similar to what we obtained from the experiment. The next table 4.1 shows a comparison of shear and tensile stress values between the experiment and ANSYS simulation at yield point, proportionality point, and maximum point respectively. In this table we will convert N.mm to N.m to be consistent throughout the report. Interpolation will be used to determine more accurate values.

Table 4.1: Comparison of shear and tensile stress values

Torque (N.m)	Experimental Shear stress (Mpa)	Simulation Shear stress (Mpa)	% Difference	Experimental Tensile stress (Mpa)	Simulation Tensile stress (Mpa)
3.98	240	302.52	20.67	412.94	524.3
4.37	260	332.16	21.72	450.61	575.67
8.45	505	642.28	21.37	875.22	1113.14

The table 4.1 shows a comparison of shear and tensile stress values between experiment and simulation at yield, proportionality, and maximum points, respectively. The table uses N.m as a unit for torque, and MPa for the stresses.

The table shows a difference in the values between the two methods. Simulation values are higher than the values from the experiment. This is expected because the simulation show the results for a perfect test where no other factors may undermine the results values.

The table uses the values 3.98 N.m, 4.37 N.m, and 8.45 N.m to represent the torque values applied at yield, proportionality, and maximum points in the experiment. The stress values for the simulation in the table were interpolated for more accurate comparison.

4.4.3.3 Discussion and analysis

The values obtained from ANSYS simulation was approximately 20 percent higher than the experimental values. This difference in values can be referred to many reasons like human error, torsion machine error, and dimension errors as mentioned in previous sections of this chapter. Also the specimen could have some defects that affected the outcome results.

However, the properties used for ANSYS simulation was for Grade 1 pure titanium. These properties apparently differ from the specimen properties that we used in the experiment. From the values of yield and maximum stresses we obtained in the experiment, the specimen

properties could be more or less in between Grade 1 and Grade 2. This has contributed to the 20 percent difference in both yield and maximum shear and tensile stresses.

Moreover, ANSYS simulation is more accurate within the elastic region of the stress strain curve. This accuracy decreases towards non-linear region of the curve. Further points could be selected in the non-linear region to increase the accuracy. Another separate simulation for Grade 2 pure titanium is required to determine this factor as well.

Overall results are acceptable and verifies the results obtained from experiment with minor differences. The dynamic nature of the experiment will add the difference when compared to the static structural analysis done by ANSYS. The torsion property of pure titanium obtained from experiment have been verified with F.E.M with 20 percent difference between the experimental and numerical analysis.

Chapter 5: Project Management

5.1 Project Plan

5.2 Contribution of Team Members

5.3 Project Execution Monitoring

5.4 Challenges and Decision Making

5.5 Project Bill of Materials and Budget

Chapter 5: Project Management

The success of a project is influenced by many factors but one of the most significant factors is project management that involves organizing, planning and managing of resources to accomplish all the activities related to the project. Project management revolves around 5 phases namely Initiating phase, Planning phase, Executing phase, Monitoring and Controlling phase and finally Closing phase. These phases ensure that goals and objectives are met and resources are well distributed throughout the project; when followed and well execute they reduce chances of project failure. Besides, it helps in managing constraints such as scope, time, and quality so that all the necessary changes can be made in a timely manner. It is of importance noting that constraints can take the project off course if care is not exercised since they determine how effective the program is followed.

Complex projects like these one involving biomaterials which revolves around science and technology require clear understanding of the goals and objectives since they require high investment of resources. This helps in managing mechanical and biological compatibilities which influences the processes of testing torsional property of Nano structure pure titanium. Hence, it is of importance to manage this project for its effective initiation, ability to plan and schedule activities, determine the execution plan, monitor progress and control the activities for successful completion. It is through project management that performance and productivity of a project can be assessed.

5.1 Project Plan:

Planning is an important element in a project because they give a preview of what is to be done and who is responsible for execution. It saves time to ensure deadlines are met as well as giving smooth transition from one activity to another. For ease of execution and coordination in testing the torsional property of Nano structured titanium project, different activities were assigned to the team members for this project to ensure that every activity was taken care of properly. For achievement of set milestones, planning is of essence so as to avoid failures that face many projects which eventually fail. The tasks were broken down into list of activities to be executed by the members of the project as follows:

5.2 Contribution of Team Members:

Ahmed Ali alzhairani: AAZ, Saleh Alshemmary: SMS, masoud almarri: MSM, Mohammed Alshehri MMS, Saleh Alshemary: SMA, Ahmeed al alahmeed: AMA

Table 5.1: Project Work Distribution

Project Tasks Distribution					
Task		Member	%	Duration	
Bi-weekly meeting		To check the progress of the project for each phase	AAZ (Team leader)	20	Fortnight
Gantt chart		To allocate all the activities in the project timeline.	SMS	10	3 rd & 4 th Week
Design methodology	Project Architecture Diagram and Preparation for (copper, pure Ti , Nano structured Ti , Torsion testing machine NDW 500)	Preparation	MSM	10	5 th to 8 th Week
		Implementation	MMS	10	
Machining		<ul style="list-style-type: none"> - Copper by lathe machine and mailing machine - Ti by lathe machine and mailing machine - Nano structured Ti by CNC wire cut machine 	SMA	10	7 th to 12 th Week
			AMA	10	
FEA(Finite Element Analysis)		Solid work simulation	MSM	10	8 th to 12 th Week
		Analysis	MMS	10	
Qassem trip		To witness the ECAP process for Ti			12 th Week
Experiment		Using the torsion machine done by the team for all specimens.			9 th to 12 th Week
Result and discussion			AMZ	10	7 th to 13 th Week
				100	

5.3 Project Execution Monitoring:

Some of the various activities that the team members will undertake will be:

- Meetings with Advisors Bi- weekly meeting to discuss the barrier – this will help in evaluating the progress of the project and understand how to face the existing challenges. It will be like a mentorship program on how to keep the project in course and avoid issues that cause failures.
- Team meetings – This will be held among the team members to discuss on issues related to the project; the members will report their progress on the assigned tasks and share the challenges they are facing. Besides, the meetings will be a brainstorming session where perspectives on all tasks and ideas are expanded; this gives the one handling the task an easy time as well as widening their view about the task assigned.
- Other activities- these are tasks that related to the machines used in the project for example fixing the torsion machine whenever they have issues or communicating with torsion machine vendors. Moreover, other activities would include searching for work shop to do the machining for the specimens. This ensures that the equipment is in the right order and can be used when they are needed; this increases effectiveness and reduces time wastage.

5.4 Challenges and Decision Making

As any project, there are challenges and obstacles our project has faced some challenges. Some of these challenges are out of our control and some of them are under our control. However, we manage to exceed these challenges. This section present these challenges and how did we solve them.

5.4.1 Delay of the materials

Nano structure pure Titanium with two passes and with four passes supposed to arrive in 1st of April. However, there was a delay from Qassim University that make them change the date to 1st of May. Therefore, the machining had been delayed which delayed our project. We solve the problem by finishing other tasks that scheduled after the arrival of the materials so, we try to finish on time.

5.4.2 Unavailable equipment for machining materials at the university

Prince Mohammed Bin Fahd University have limitations in the equipment. In addition, PMU did not have agreement with any workshop helping the students to work in their projects. We solved this problem by finding a workshop deal their work precise and accurate.

5.4.3 Unavailable ANSYS design program

ANSYS is design program designing by finite elements analysis. In our project we planned to use it so, we have additional results. The problem was that the mechanical department promised us to provide it, but the process had long time for that we couldn't use it. We solve the problem by using Solidworks to get similar results.

5.4.4 Unready Torsion Test Machine

The torsion test machine had some technical problems. We could not perform our experiment because of these problems. We communicated with the finder to solve these problems so, we did the test.

5.4.5 Failed Copper Specimens

During the experiments, the Copper specimens failed because of inappropriate torsion test. We solve this problem by machining additional two specimens of copper.

5.5 Project Bill of Materials and Budget

Table 5.2: Project Bill of Materials and Budget

Materials/Process/Task	Comments	Cost
Plane Tickets	From Dammam to Qassim go and return 622 for each	3110 SR
Rental Car	Rented car for transportation in Qassim	150 SR
Copper rode	16 mm thickness and 300 mm long	32 SR
Copper Large specimen machining. Failed	Machined for first time in Modern Precision workshop	350 SR
Copper Small specimen machining. Failed	Machined for first time in Modern Precision workshop	250 SR
Copper Large specimen machining.	Machined for first time in Modern Precision workshop	180 SR
Copper Small specimen machining.	Machined for first time in Modern Precision workshop	180 SR
Micro structure pure Titanium rode	Machined as regular customer in Modern Precision workshop	180 SR
Nano structure pure Titanium two passes machining	Machined as regular customer in Modern Precision workshop	180 SR
Nano structure pure Titanium four passes machining	Machined as regular customer in Modern Precision workshop	180 SR
Roll up banner	Done by Naif Stationery	250 SR
Brochure	15 copies each copy cost 4 SR	60 SR
Total		5102 SR

Chapter 6: Project Analysis

6.1 life-long learning

6.2 Impact of Engineering Solutions

6.3 Contemporary Issues Addressed

Chapter 6: Project Analysis

6.1 life-long learning

6.1.1 Torsion machine

Torsion machines, also known as torque testing machines, are devices that are used to measure different factors such as rigidity, torsional strength or the stress-strain property. By the help of these machines the product quality of different substances can be checked. These accuracies can range from a few milli nanometers to 30,000 or sometimes even 75,000 nanometers. Some of these machines are capable of providing weighing and loading properties separately in both directions of rotation. Owing to these properties it is easy to determine the behavior of a given specimen when exposed to torque loading given in both directions at the same time. The final torque load can also be determined in a similar fashion. In this circumstance we were given titanium to conclude its torsional properties. Titanium was inserted into this machine and different forms of data were analyzed.

6.1.2 Solid work program

A program named as SolidWorks is usually used to deal with metals like titanium owing to its ease of use. SolidWorks is actually a computer program that uses Computer Aided Engineering (CAE), Computer-Aided Design (CAD) and Microsoft Windows for operation. In simpler words, SolidWorks is a modeler that creates both 2D and 3D models through parametric feature-based methodology. The program can be used to create any model, quickly and efficiently, without facing any complications. Furthermore, it is a cost- effective modeler.

SolidWorks has the biggest advantage of being user-friendly as it is quite easy to operate. The program has a lot of integrated detailing applications such as e-drawings, PhotoView 360, Circute Works, solid modeling and a lot more. After acquiring complete data about titanium, we

used SolidWorks program to create a solid model of titanium. It was convenient and covered various aspects of the development of titanium model in depth.

6.1.3 Ansys program

ANSYS is mechanical software which is used extensively by different organizations across the world to solve various complexities like some thermal problems. This software actually provides a solution that allows a complete access to different aspects of a particular specimen. These may include a complete data regarding model analysis including the deformations, stresses, and vibrational characteristics.

ANSYS software can break the complexities of different assemblies and can expose them to realistic approaches. This mechanical software utilizes a set of graphical tools to calculate vibration, motion and strength of a particular system. The results are then visualized and different schemes are proposed to modify and optimize a design. ANSYS makes use of physics in all aspects to provide access to any field of simulation. The application, in fact, takes simulation to an entirely different level by promising driving innovations, increasing efficiency and decreasing physical barriers. All of this work enables the operation of simulated tests which might not be possible to carry out in any other case.

Because of the benefits that come along ANSYS we decided to check our specimen (titanium) by using this software and to analyze it by performing some simulated tests on it.

6.1.4 New knowledge

The need for core materials used in the making of various biomedical instruments grows in the United States these days. The demand is increases with the rise in the number of aging people and their needs for devices like hip replacements. The ever rising need for hip replacements can be justified by a survey which states that 272,000 surgeries involving these devices will have been performed by the end of 2030. Moreover, it also states that about 12.8

percent of these surgeries are mere revisions of the hip replacements inserted previously. The insertion of these hip replacements via a surgical procedure increases the life expectancy by 17 to 19 years in the people who are above the age of 65. This implies that every patient who will go through a hip replacement process will definitely need to undergo a revision surgery.

In such times when there is a dire need of biomedical devices, titanium (which is the specimen that we use) is an important material for manufacturing such devices. It is not only used to make hip replacements but is also a material needed for the production of replacements for shoulders and knees. Titanium, when used in the form of an alloy, depicts some suitable properties which include a low rate of corrosion, high biocompatibility, and a low modulus. Titanium alloys also present a great Osseo integration relative to other materials used for making implants. Therefore, titanium is regarded as the best material for all orthopedic implants.

6.2 Impact of Engineering Solutions

6.21 Economic Impact

Titanium has been found to be amazingly useful in the health industry due to its incredible properties. It is possibly the only naturally occurring metal that has an ability to make a connection with human bone spontaneously. The bonding does not require the use of any material as an adhesive. Titanium is able to tolerate harsh conditions of the human body because it is resistant to corrosion. Also, it is a potentially non-toxic substance that cannot harm the body in any way. Due to these reasons the use of titanium in the medical field has long become a widespread trend. It is preferred by many medical specialists as the best material for making diverse medical devices. These devices include orthopedic implants for hips, shoulders, and joints. Even dental implants, both single and double stage, are made out of titanium due to its effectiveness. Nowadays it is implied in the manufacturing of pacemakers for the heart patients. Titanium can be regarded as a life changing substance because it is biocompatible and every human body can handle it without harming itself.

Titanium has remained the most favored metal in the medical field for more than two decades now. What makes it perfect for the medical field is its unique proportion between strength and weight. In addition to being used for making medical instruments, other things, such as wheelchairs, are also made up of titanium due to its light weight. It can be said that the use of titanium helps medical business and overall economy to flourish.

6.2.2 Social Impact

It is anticipated that the use of titanium in the medical field will increase drastically in the coming years due to the positive effects it has on the overall society. The society benefits from the use of this metal in a lot of ways, especially when it comes to healthcare. Many titanium-based biological devices are making the lives of thousands of people better and more active. Moreover, the use of titanium has also relieved the aging patients of the pain by providing them all the necessary mechanical properties. The success rate of titanium implants is high and different surveys are suggestive of the fact that these implants add comfort to the lives of people.

The quality of life of the people suffering from joint problems has been improved due to the use of titanium within the framework of health care system. Implant surgeries for hips or knees are often regarded as less important; however, thousands of people in the United States are in dire need of these implants. Additionally, the surgical implantation of titanium-based medical devices requires a relatively shorter duration. Titanium is cost-effective, therefore, these implants are easy to afford. These implants are able to prolong the life expectancy of older people for up to 17 years.

6.2.3 Environment Impact

Titanium is preferred over other materials because it is eco-friendly. Titanium has been found to be as safe for the environment as it is for humans. It is considered to be hypoallergenic in nature, which means it has a very low potential for inducing an allergic reaction. Titanium has been listed among the most environment-friendly metals that exist in nature. Due to its low weight and adhesive nature titanium sticks to the bone in a more firm way than any other

material. In this way, it cannot change its position despite being exposed to intense or excessive body movements. The implants made up of pure titanium or titanium alloys can be recycled, therefore, there is no need to dump them and potentiate any kind of pollution. As titanium has a corrosion-free nature, it does not harm the environment and does not lead to air, water, and land pollution. Generally, it has a good impact on the environment.

6.3 Contemporary Issues Addressed

6.3.1 Cost

There were certain problems while using titanium for making implants. The primary problem was the rising cost of the parts that were made up of titanium alloys. Additionally, the workshops where titanium was sent to get cut and modeled were quite expensive as they charged a lot. Purchasing and processing of titanium cost us a lot of money. As there are very few workshops that deal with titanium, it is generally difficult to find a workshop which ensures good quality at an affordable price.

6.3.2 Searching for machines

The appropriate tools and machines needed to cut and process the metal as per requirement caused a lot of problems as most of these tools were difficult to find. One of such machines is the waterjet that ensures a full efficiency in cutting the complex parts and leaves behind no zones which have been affected by heat. This technique does not add any additional stress on the titanium being used. The high precision of waterjet guarantees that the titanium specimen does not need any secondary operations. Moreover, waterjet makes sure to cut short the consumption of the titanium to as minimum amount as possible, hence, making the process more cost-effective.

CNC is another machine that is used in the fabrication of any metal including titanium. The use of CNC is appreciable as it offers a high rate of performance. The machine can cut both 2D and 3D parts to fabricate any model. The operation of CNC is quite simple to learn. CNC is even more economical as compared to a waterjet. Both of these machines were rare to find at any workshop and their shortage caused a lot of trouble while processing titanium for making implants.

Chapter 7: Conclusions and Future Recommendations

7.1 Conclusion

7.2 Future Recommendations

Chapter 7: Conclusions and Future Recommendations

7.1 Summary & Conclusion

In this study, the application of Nano structured titanium technology in the production of biomedical products has been explored. Nano – structure Titanium have produced using ECAP process. The Nano- Structured Titanium properties have been assessed through experimental work and it was shown that the Ti property is enhanced, so it can meet the needs for biomaterials using ECAP process. The results of our testing shows that The Nano-structured yield strength of pure titanium has increased by 164%, ECAP process enhances the strength of the pure titanium by 44.6% and the ECAP process lowered the ductility of the pure titanium by 62.4%.

One fundamental method has been employed in this study to test the property of Nano structured titanium its use in biomedical application, the methods is surface modification. With the help of the method, the torsional behavior of the Nano-structured titanium substance was investigated with torsion under intense pressure. However, a number of challenges were experienced in this study, for instance, three was the constraints of our system design is the sustainability of the results. The researchers were strictly required to have similar results in each experiment in order for the result to be valid something that was a bit difficult to achieve. Another challenge was experienced on the economical side of the experiment. Titanium itself is a costly material to obtain and machining of the titanium into the exact parameter needed a series of the test. Nevertheless, lots of lessons were learnt from this study some of which include the use Gant chart in establishing projects schedules, how to handle a comprehensive project, the use of team work and importance of marinating time among other moral aspects.

7.2 Future recommendation

7.2.1 The Material should be tested using Live Stock

The ASTM standard was used to test the torsional property of the Nano-structured titanium. The test approach was an objective approach that is similar to the preliminary laboratory stages of product development for medical use. The practical test for product suitability for medical use that is traditional for medical application, however, was not conducted

and this undermines confidence in the developed results on biomedical properties of Nano-structured titanium. A test, using livestock, especially those traditionally used for testing new medical products, is recommended for a future study. Such a test is likely to develop practical information on the suitability and biocompatibility features of the material, as well as the practical consequences of the material for cost and benefits analysis. Consequently, using livestock for testing will improve the validity and reliability of the data for generalizability of the results to other animals, including humans. The revelation of the practical cost of the material's usage in animals, as its limitations or adverse effects would identify, would promote evidence-based practice towards best practice in the use of biomedical implants.

7.2.2 Material's Biocompatibility needs to be Investigated Further

The limited scope of the study to preliminary laboratory observations, which are further limited to simulations instead of practical applications in humans or livestock, identifies the need for further research on the biocompatibility of the Nano-structured material. Literature supports positive effects of ECAP treatment on biocompatibility features such as surface texture and corrosiveness. The biocompatibility features depend on the bio-environment around the used material and possible changes in the environment could undermine the properties. Simulations may also lack the environmental properties of a natural body and recommendations are made for further research on the biomedical properties, using livestock.

7.2.3 Mechanical Properties of the Material needs to be Investigated Further

Mechanical properties of biomaterials, such as strength, resistance to deformation, and fatigue, are also important to the use of the biomaterials and the limited scope of the study to simulated research undermines confidence in the properties that the material can exhibit after an implant. Further research on the mechanical properties of the biomaterial through the simulation of the environment in which the material is to be implanted or using livestock for practical implantation is recommended. The further research will ensure validity of the information on the mechanical properties of the material for informing best practice.

7.2.4 Micro-structured investigation should be performed on the Material to Measure the Size Grain

The grain size has a significant implication on the mechanical suitability of materials for biomedical use because of its effects on corrosion. The use of a corrosive material can undermine the biocompatibility and other mechanical properties of a biomaterial to undermine its use. Positive results of the study remain insignificant to the biomedical applicability of the Nano-structured titanium if the grain size is larger than the threshold level. A recommendation, therefore, is made for a micro-structured study on the biomaterial for the determination of its grain size.

References

- [1] Antunes, R. & Oliveira, M. (2012). Corrosion fatigue of biomedical alloys: Mechanisms and mitigation. *The Acta Biomaterials*, 8(2012), 937-962.
- [2] Rack, H. & Qazi, J. (2006). Titanium alloys for biomedical applications. *The Material Science & Engineering, C* 26(2006), 1269-1277.
- [3] Niinomi, M. (1998). Mechanical properties of biomedical titanium alloys. *The Material Science & Engineering, A*243(1998), 231-236.
- [4] Hacisalihoglu, I., Samancioglu, A., Yildiz, F., Purcek, G., & Alsaran, A. (2014). Tribocorrosion properties of different type titanium alloys in simulated body fluid. *The Wear*, 332-333(2015), 679-686.
- [5] Suresh, K., Geetha, M., Richard, C., Landoulsi, J., Ramasawmy, H., Suwas, S., & Asokamani, R. (2012). Effect of equal channel angular extrusion on wear and corrosion behavior of the orthopedic Ti–13Nb–13Zr alloy in simulated body fluid. *The Materials Science & Engineering*, 32(2012), 763-771.
- [6] Raducanu, D., Vasilescu, E., Cojocaru, V., Cinca, I., Drob, P., Vasilescu, C., & Drob, S. (2011). Mechanical and corrosion resistance of a new nanostructured Ti-Zr-Ta-Nb alloy. *The Journal of the Mechanical Behavior of Biomedical Materials*, 4(2011), 1421-1430.
- [7] Zheng, C., Nie, F., Zheng, Y., Cheng, Y., Wei, C., & Valiev, R. (2011). Enhanced in vitro biocompatibility of ultrafine-grained titanium with hierarchical porous surface. *The Applied Surface Science*, 257(2011), 5634-5640.
- [8] Zhao, X., Yang, X., Liu, X., Wang, X., & Langdon, T. (2010). The processing of pure titanium through multiple passes of ECAP at room temperature. *The Materials Science & Engineering, A* 527(2010), 6335-6339.

- [9] Elias, C., Meyers, M., Valiev, R., & Monteiro, S. (2013). Ultrafine grained titanium for biomedical applications: An overview of performance. *The Journal of Material Science & Technology*, 2(4), 340-350.
- [10] Bindu, S., Sanosh, K., Smetana, K., Balakrishnan, A., & Kim, T. (2009). An in vivo evaluation of ultra-fine grained titanium implants. *The Journal of Material Science & Technology*, 25(4), 556-560.
- [11] Shah, F., Trobos, M., Thomsen, P. & Palmquist, P. (2015). Commercially pure titanium (cp-Ti) versus titanium alloy (Ti6Al4V) materials as bone anchored implants- Is one truly better than the other? *The Materials Science & Engineering, C* 62(2016), 960-966.
- [12] Latysh, V., Krallics, G., Alexandrov, I., & Fodor, A. (2006). Application of bulk nanostructured materials in medicine. *The Current Applied Physics*, 6(2016), 262-266.
- [13] Ueno, H., Kakihata, K., Kaneko, Y., Hashimoto, S., & Vinogradov, A. (2011). Enhanced fatigue properties of nanostructured austenitic SUS 316 stainless steel. *The Acta Materials*, 59(2011), 7060-7069.
- [14] Ávila Ambriz, J. L., Almaraz, G. M. D., Gómez, E. C., & Juárez, J. C. V. (2015). Fatigue Endurance Under Rotating Bending and Torsion Testing, of AISI 6063-T5 Aluminum Alloy. *International Journal of Advanced Materials Research*, 1(4), 120-125.
- [15] Dabirrahmani, D., Bokor, D., & Appleyard, R. (2014). A novel dynamic mechanical testing technique for reverse shoulder replacements. *Annals of biomedical engineering*, 42(4), 727-732.
- [16] Horgan, C. O., & Murphy, J. G. (2015). Reverse Poynting effects in the torsion of soft biomaterials. *Journal of Elasticity*, 118(2), 127-140.

Appendix A

	SDP – WEEKLY MEETING REPORT
	Department of Electrical Engineering Prince Mohammad bin Fahd University

SEMESTER:	Spring	ACADEMIC YEAR:	2016/2017
PROJECT TITLE	Torsional property of Nano Structured Titanium for use in Biomedical Application		
SUPERVISORS	Advisor: Dr.Faramarz Djavanroodi Co-advisor: Dr. Nader Sawalhi		

Month 1: February

ID Number	Member Name
Ahmad Al-Ahmad (AMA)	201102813
Ahmed Al-Zahrani* (AAZ)	201300471
Masoud Al-Mari (MSM)	201301057
Mohammed Al-Shehri (MMS)	201300159
Saleh Al-Shammeri (SMS)	201203373

List the tasks conducted this month and the team member assigned to conduct these tasks

#	Task description	Team member assigned	Progress 0%-100%	Delivery proof
1	Gantt chart	SMS	100%	
2	Introduction	SMS, AMA, AAZ	100%	
3	Literature Review	MSM, MMS, AAZ	100%	
4	Modifying Literature Review	ALL	100%	

List the tasks planned for the month of March and the team member/s assigned to conduct these tasks

#	Task description	Team member/s assigned
1	Searching for Workshop	SMS, AMA
2	Drawing Solidworks Module	SMS
3	Simulation	MSM, MMS, AAZ
4	Writing Chapter 3	MSM, MMS, AAZ

- **To be Filled by Project Supervisor and team leader:**
- **Please have your supervisor fill according to the criteria shown below**

Outcome f: An understanding of professional and ethical responsibility.				
Criteria	None (1)	Low (2)	Moderate (3)	High (4)
f1. Demonstrate an understanding of engineering professional and ethical standards in dealing with public safety and interest	Fails to Demonstrate an understanding of engineering professional and ethical standards in dealing with public safety and interest	Shows limited and less than adequate understanding of engineering professional and ethical standards in dealing with public safety and interest	Demonstrates satisfactory an understanding of engineering professional and ethical standards in dealing with public safety and interest	Understands appropriately and accurately the engineering professional and ethical standards in dealing with public safety and interest
Outcome d: An ability to function on multidisciplinary teams.				
Criteria	None (1)	Low (2)	Moderate (3)	High (4)
d1. Ability to develop team work plans and	Fails to develop team work plans and allocate	Shows limited and less than adequate ability to develop	Demonstrates satisfactory ability to	Understands and applies proper and accurate team work

allocate resources and tasks	resources and tasks	team work plans and allocate resources and tasks	develop team work plans and allocate resources and tasks	plans and allocate resources and tasks
d2. Ability to participate and function effectively in team work projects	Fails to participate and function effectively in team work projects	Shows limited and less than adequate ability to participate and function effectively in team work projects	Demonstrates satisfactory ability to participate and function effectively in team work projects	Understands and participates properly and function effectively in team work projects
d3. Ability to communicate effectively with team members	Fails to communicate effectively with team members	Shows limited and less than adequate ability to communicate effectively with team members	Demonstrates satisfactory ability to communicate effectively with team members	3. Understands and communicates properly and effectively with team members

Indicate the extent to which you agree with the above statement, using a scale of 1-4 (1=None; 2=Low; 3=Moderate; 4=High)

#	Name	Criteria (d1)	Criteria (d2)	Criteria (d3)	Criteria (f1)
1	Ahmad Al-Ahmad	4	4	4	4
2	Ahmed Al-Zahrani*	4	4	4	4
3	Masoud Al-Mari	4	4	4	4
4	Mohammed Al-Shehri	4	4	4	4

	SDP – WEEKLY MEETING REPORT
	Department of Electrical Engineering Prince Mohammad bin Fahd University

SEMESTER:	Spring	ACADEMIC YEAR:	2016/2017
PROJECT TITLE	Torsional property of Nano Structured Titanium for use in Biomedical Application		
SUPERVISORS	Advisor: Dr.Faramarz Djavanroodi Co-advisor: Dr. Nader Sawalhi		

Month 1: April

ID Number	Member Name
Ahmad Al-Ahmad (AMA)	201102813
Ahmed Al-Zahrani* (AAZ)	201300471
Masoud Al-Mari (MSM)	201301057
Mohammed Al-Shehri (MMS)	201300159
Saleh Al-Shammeri (SMS)	201203373

List the tasks conducted this month and the team member assigned to conduct these tasks

#	Task description	Team member assigned	Progress 0%-100%	Delivery proof
1	Machining Copper, Ti	SMS, AMA	80%	
2	Qassim Trip Booking	SMS	100%	
3	Qassim Trip	MSM, MMS, AAZ	100%	
4	Simulation	MSM, AAZ	90%	
5	Midterm Presentation	All	100%	
6	Modifying Design methodology and Implementation	MSM, MMS	100%	

List the tasks planned for the month of May and the team member/s assigned to conduct these tasks

#	Task description	Team member/s assigned
1	Machining Copper, Ti	SMS, AMA
2	Torsion Test	AAZ, SMS
3	Simulation	AAZ, MSM
4	Final Presentation preparation	MSM
5	Final Presentation	All
6	Writing chapter 5, 6	MSM, SMS, AMA

- To be Filled by Project Supervisor and team leader:
- Please have your supervisor fill according to the criteria shown below

Outcome f:				
An understanding of professional and ethical responsibility.				
Criteria	None (1)	Low (2)	Moderate (3)	High (4)
f1. Demonstrate an understanding of engineering professional and ethical standards in dealing with public safety and interest	Fails to Demonstrate an understanding of engineering professional and ethical standards in dealing with public safety and interest	Shows limited and less than adequate understanding of engineering professional and ethical standards in dealing with public safety and interest	Demonstrates satisfactory an understanding of engineering professional and ethical standards in dealing with public safety and interest	Understands appropriately and accurately the engineering professional and ethical standards in dealing with public safety and interest
Outcome d:				
An ability to function on multidisciplinary teams.				
Criteria	None (1)	Low (2)	Moderate (3)	High (4)

d1. Ability to develop team work plans and allocate resources and tasks	Fails to develop team work plans and allocate resources and tasks	Shows limited and less than adequate ability to develop team work plans and allocate resources and tasks	Demonstrates satisfactory ability to develop team work plans and allocate resources and tasks	Understands and applies proper and accurate team work plans and allocate resources and tasks
d2. Ability to participate and function effectively in team work projects	Fails to participate and function effectively in team work projects	Shows limited and less than adequate ability to participate and function effectively in team work projects	Demonstrates satisfactory ability to participate and function effectively in team work projects	Understands and participates properly and function effectively in team work projects
d3. Ability to communicate effectively with team members	Fails to communicate effectively with team members	Shows limited and less than adequate ability to communicate effectively with team members	Demonstrates satisfactory ability to communicate effectively with team members	3. Understands and communicates properly and effectively with team members

Indicate the extent to which you agree with the above statement, using a scale of 1-4 (1=None; 2=Low; 3=Moderate; 4=High)

#	Name	Criteria (d1)	Criteria (d2)	Criteria (d3)	Criteria (f1)
1	Ahmad Al-Ahmad	4	4	4	4
2	Ahmed Al-Zahrani*	4	4	4	4
3	Masoud Al-Mari	4	4	4	4
4	Mohammed Al-Shehri	4	4	4	4

	SDP – WEEKLY MEETING REPORT
	Department of Electrical Engineering Prince Mohammad bin Fahd University

SEMESTER:	Spring	ACADEMIC YEAR:	2016/2017
PROJECT TITLE	Torsional property of Nano Structured Titanium for use in Biomedical Application		
SUPERVISORS	Advisor: Dr.Faramarz Djavanroodi Co-advisor: Dr. Nader Sawalhi		

Month 3: April

ID Number	Member Name
Ahmad Al-Ahmad (AMA)	201102813
Ahmed Al-Zahrani* (AAZ)	201300471
Masoud Al-Mari (MSM)	201301057
Mohammed Al-Shehri (MMS)	201300159
Saleh Al-Shammeri (SMS)	201203373

List the tasks conducted this month and the team member assigned to conduct these tasks

#	Task description	Team member assigned	Progress 0%-100%	Delivery proof
1	Machining Copper, Ti	SMS, AMA	80%	
2	Qassim Trip Booking	SMS	100%	
3	Qassim Trip	MSM, MMS, AAZ	100%	
4	Simulation	MSM, AAZ	90%	
5	Midterm Presentation	All	100%	
6	Modifying Design methodology and Implementation	MSM, MMS	100%	

List the tasks planned for the month of May and the team member/s assigned to conduct these tasks

#	Task description	Team member/s assigned
1	Machining Copper, Ti	SMS, AMA
2	Torsion Test	AAZ, SMS
3	Simulation	AAZ, MSM
4	Final Presentation preparation	MSM
5	Final Presentation	All
6	Writing chapter 5, 6	MSM, SMS, AMA
7	Roll up, Brochure, Video	SMS, MMS, AMA

- To be Filled by Project Supervisor and team leader:
- Please have your supervisor fill according to the criteria shown below

Outcome f: An understanding of professional and ethical responsibility.				
Criteria	None (1)	Low (2)	Moderate (3)	High (4)
f1. Demonstrate an understanding of engineering professional and ethical standards in dealing with public safety and interest	Fails to Demonstrate an understanding of engineering professional and ethical standards in dealing with public safety and interest	Shows limited and less than adequate understanding of engineering professional and ethical standards in dealing with public safety and interest	Demonstrates satisfactory an understanding of engineering professional and ethical standards in dealing with public safety and interest	Understands appropriately and accurately the engineering professional and ethical standards in dealing with public safety and interest

Outcome d: An ability to function on multidisciplinary teams.				
---	--	--	--	--

Criteria	None (1)	Low (2)	Moderate (3)	High (4)
d1. Ability to develop team work plans and allocate resources and tasks	Fails to develop team work plans and allocate resources and tasks	Shows limited and less than adequate ability to develop team work plans and allocate resources and tasks	Demonstrates satisfactory ability to develop team work plans and allocate resources and tasks	Understands and applies proper and accurate team work plans and allocate resources and tasks
d2. Ability to participate and function effectively in team work projects	Fails to participate and function effectively in team work projects	Shows limited and less than adequate ability to participate and function effectively in team work projects	Demonstrates satisfactory ability to participate and function effectively in team work projects	Understands and participates properly and function effectively in team work projects
d3. Ability to communicate effectively with team members	Fails to communicate effectively with team members	Shows limited and less than adequate ability to communicate effectively with team members	Demonstrates satisfactory ability to communicate effectively with team members	3. Understands and communicates properly and effectively with team members

Indicate the extent to which you agree with the above statement, using a scale of 1-4
(1=None; 2=Low; 3=Moderate; 4=High)

#	Name	Criteria (d1)	Criteria (d2)	Criteria (d3)	Criteria (f1)
1	Ahmad Al-Ahmad	4	4	4	4
2	Ahmed Al-Zahrani*	4	4	4	4
3	Masoud Al-Mari	4	4	4	4
4	Mohammed Al-Shehri	4	4	4	4

	SDP – WEEKLY MEETING REPORT
	Department of Electrical Engineering Prince Mohammad bin Fahd University

SEMESTER:	Spring	ACADEMIC YEAR:	2016/2017
PROJECT TITLE	Torsional property of Nano Structured Titanium for use in Biomedical Application		
SUPERVISORS	Advisor: Dr.Faramarz Djavanroodi Co-advisor: Dr. Nader Sawalhi		

Month 4: May

ID Number	Member Name
Ahmad Al-Ahmad (AMA)	201102813
Ahmed Al-Zahrani* (AAZ)	201300471
Masoud Al-Mari (MSM)	201301057
Mohammed Al-Shehri (MMS)	201300159
Saleh Al-Shammeri (SMS)	201203373

List the tasks conducted this month and the team member assigned to conduct these tasks

#	Task description	Team member assigned	Progress 0%-100%	Delivery proof
1	Machining Copper, Ti	SMS, AMA	100%	
2	Torsion Test	AAZ, SMS	100%	
3	Simulation	AAZ, MSM	100%	
4	Final Presentation preparation	MSM	100%	
5	Final Presentation	All	100%	
6	Writing chapter 5, 6	MSM, SMS, AMA	100%	
7	Roll up, Brochure, Video	SMS, MMS, AMA	100%	

- **To be Filled by Project Supervisor and team leader:**
- **Please have your supervisor fill according to the criteria shown below**

Outcome f: An understanding of professional and ethical responsibility.				
Criteria	None (1)	Low (2)	Moderate (3)	High (4)
f1. Demonstrate an understanding of engineering professional and ethical standards in dealing with public safety and interest	Fails to Demonstrate an understanding of engineering professional and ethical standards in dealing with public safety and interest	Shows limited and less than adequate understanding of engineering professional and ethical standards in dealing with public safety and interest	Demonstrates satisfactory an understanding of engineering professional and ethical standards in dealing with public safety and interest	Understands appropriately and accurately the engineering professional and ethical standards in dealing with public safety and interest
Outcome d: An ability to function on multidisciplinary teams.				
Criteria	None (1)	Low (2)	Moderate (3)	High (4)
d1. Ability to develop team work plans and allocate resources and tasks	Fails to develop team work plans and allocate resources and tasks	Shows limited and less than adequate ability to develop team work plans and allocate resources and tasks	Demonstrates satisfactory ability to develop team work plans and allocate resources and tasks	Understands and applies proper and accurate team work plans and allocate resources and tasks
d2. Ability to participate and function effectively in team work projects	Fails to participate and function effectively in team work projects	Shows limited and less than adequate ability to participate and function effectively in team work projects	Demonstrates satisfactory ability to participate and function effectively in team work projects	Understands and participates properly and function effectively in team work projects

d3. Ability to communicate effectively with team members	Fails to communicate effectively with team members	Shows limited and less than adequate ability to communicate effectively with team members	Demonstrates satisfactory ability to communicate effectively with team members	3. Understands and communicates properly and effectively with team members
--	--	---	--	--

Indicate the extent to which you agree with the above statement, using a scale of 1-4
(1=None; 2=Low; 3=Moderate; 4=High)

#	Name	Criteria (d1)	Criteria (d2)	Criteria (d3)	Criteria (f1)
1	Ahmad Al-Ahmad	4	4	4	4
2	Ahmed Al-Zahrani*	4	4	4	4
3	Masoud Al-Mari	4	4	4	4
4	Mohammed Al-Shehri	4	4	4	4

Appendix B

Table 5.2: Project Bill of Materials and Budget

Materials/Process/Task	Comments	Cost
Plane Tickets	From Dammam to Qassim go and return 622 for each	3110 SR
Rental Car	Rented car for transportation in Qassim	150 SR
Copper rode	16 mm thickness and 300 mm long	32 SR
Copper Large specimen machining. Failed	Machined for first time in Modern Precision workshop	350 SR
Copper Small specimen machining. Failed	Machined for first time in Modern Precision workshop	250 SR
Copper Large specimen machining.	Machined for first time in Modern Precision workshop	180 SR
Copper Small specimen machining.	Machined for first time in Modern Precision workshop	180 SR
Micro structure pure Titanium rode	Machined as regular customer in Modern Precision workshop	180 SR
Nano structure pure Titanium two passes machining	Machined as regular customer in Modern Precision workshop	180 SR
Nano structure pure Titanium four passes machining	Machined as regular customer in Modern Precision workshop	180 SR
Roll up banner	Done by Naif Stationery	250 SR
Brochure	15 copies each copy cost 4 SR	60 SR
Total		5102 SR

Appendix C

Test Report

ID:	Big Copper	Test Date:	2017-05-15
T _m :	4.27Nm	τ_m :	305MPa
T _{eL} :	2.36Nm	τ_{eL} :	168MPa
T _{p0.2} :	/Nm	$\tau_{p0.2}$:	/MPa
W:	14.03m ³	I _p :	29.12m ⁴
T1:	0.48Nm	T2:	1.79Nm
ϕ_b :	377.40		

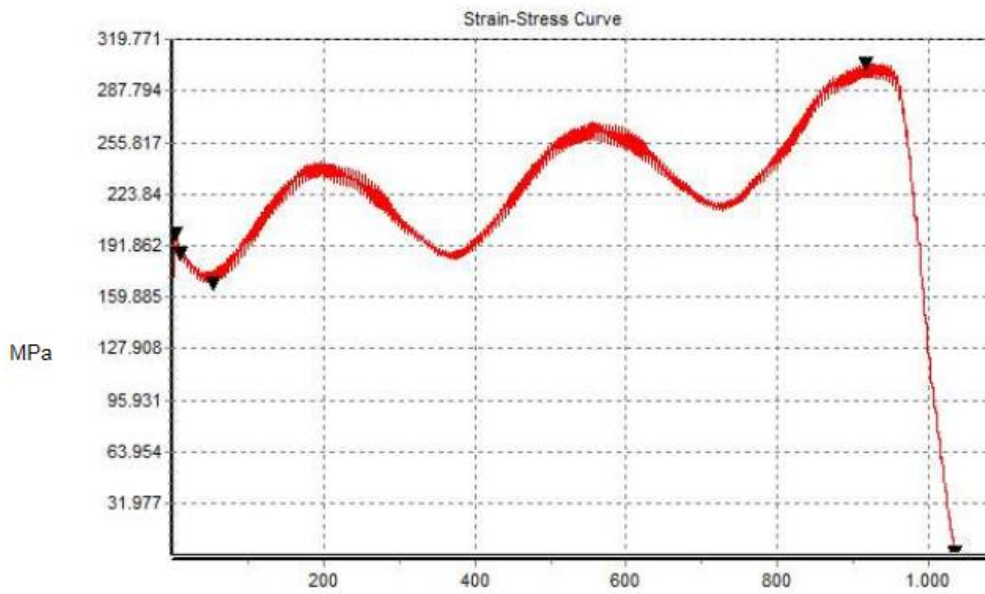

Test Report

ID:	Small Copper	Test Date:	2017-05-15
Tm:	4.01Nm	τ_m :	260MPa
TeL:	2.25Nm	τ_{eL} :	146MPa
Tp0.2:	2.49Nm	$\tau_{p0.2}$:	162MPa
W:	15.39m3	I _p :	32.94m4
T1:	1.62Nm	T2:	1.75Nm
ϕ_b :	217.54		

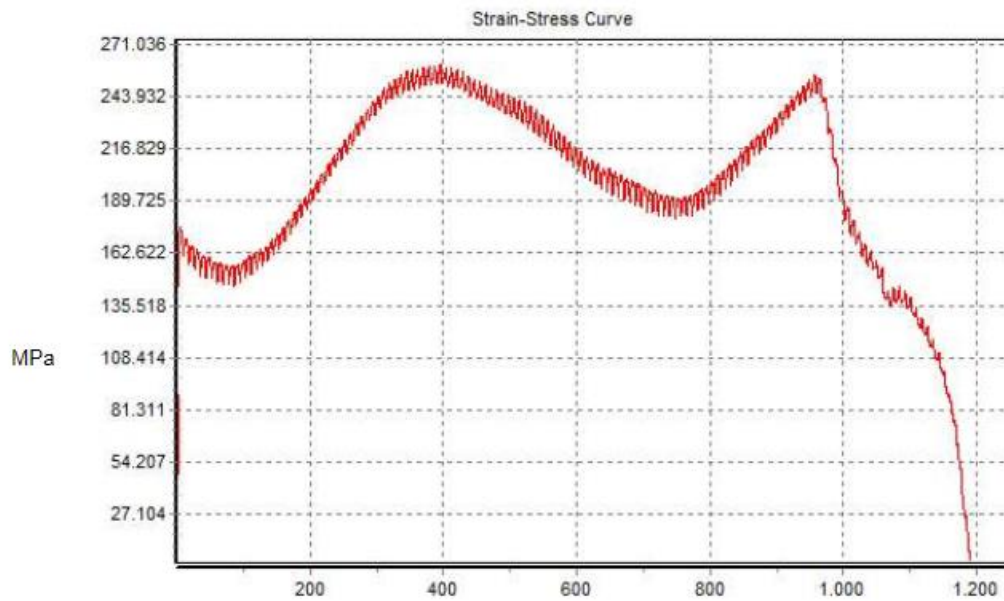

Test Report

ID:	TITANUM 1	Test Date:	2017-05-09
T _m :	8.45Nm	τ _m :	505MPa
T _{eL} :	3.98Nm	τ _{eL} :	240MPa
T _{p0.2} :	4.37Nm	τ _{p0.2} :	260MPa
W:	16.73m ³	I _p :	36.80m ⁴
T ₁ :	1.96Nm	T ₂ :	3.40Nm
φ _b :	49.68		

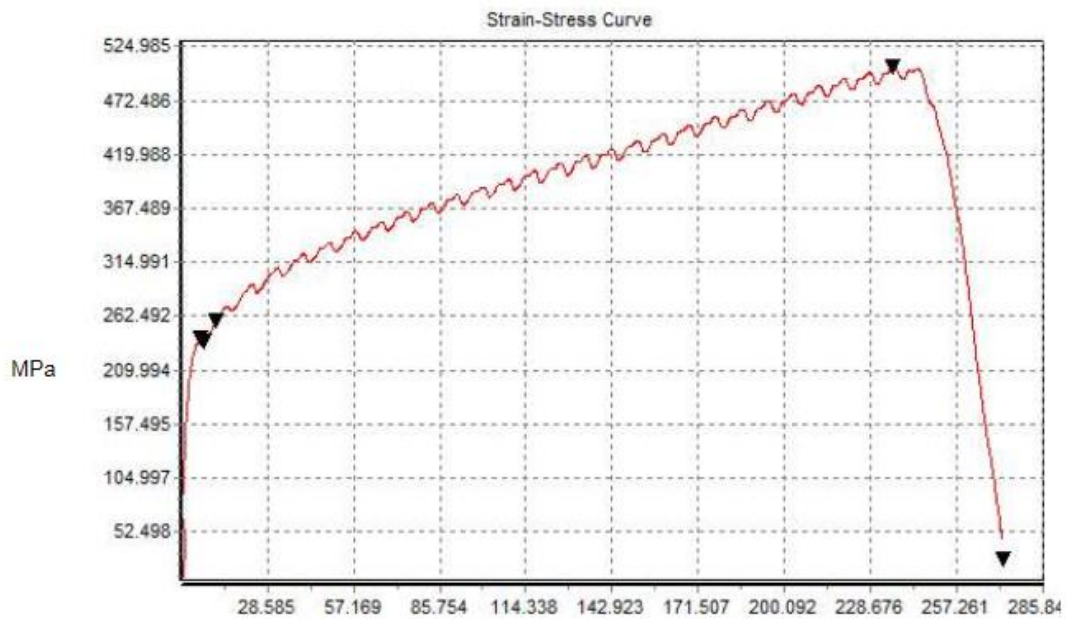

Test Report

ID:	TITANIUM 2	Test Date:	2017-05-09
T _m :	12.24Nm	τ_m :	730MPa
T _{eL} :	10.65Nm	τ_{eL} :	635MPa
T _{p0.2} :	10.54Nm	$\tau_{p0.2}$:	630MPa
W:	16.73m ³	I _p :	36.80m ⁴
T ₁ :	1.36Nm	T ₂ :	5.02Nm
ϕ_b :	38.39		

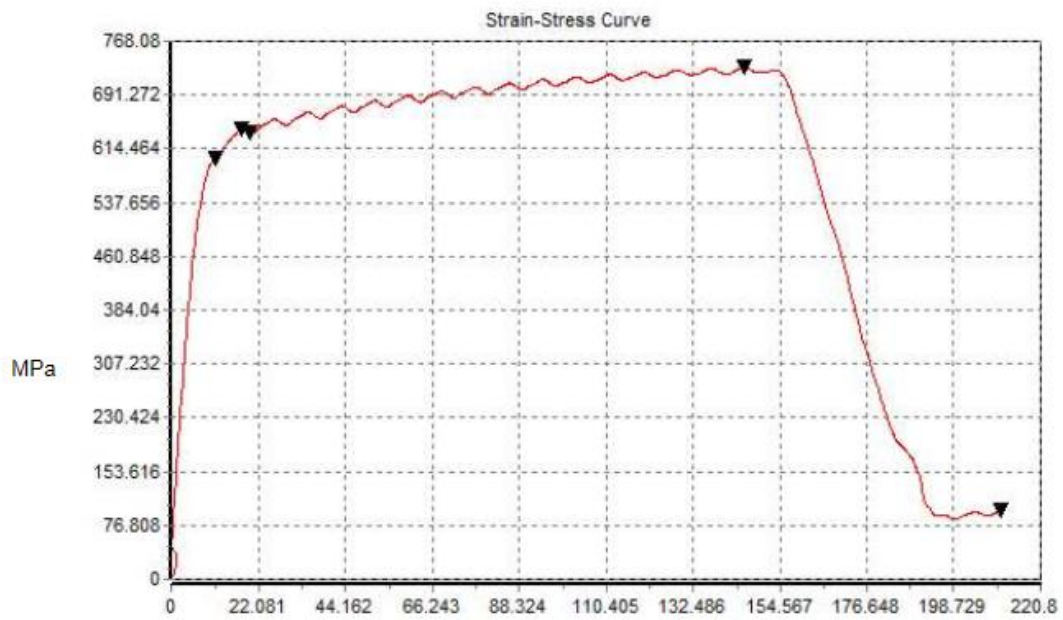

Test Report

ID:	TITANIUM 3	Test Date:	2017-05-09
Tm:	11.65Nm	τ_m :	715MPa
TeL:	0.03Nm	τ_{eL} :	2MPa
Tp0.2:	8.53Nm	$\tau_{p0.2}$:	525MPa
W:	16.27m3	Ip:	35.48m4
T1:	1.54Nm	T2:	4.72Nm
ϕ_b :	50.87		

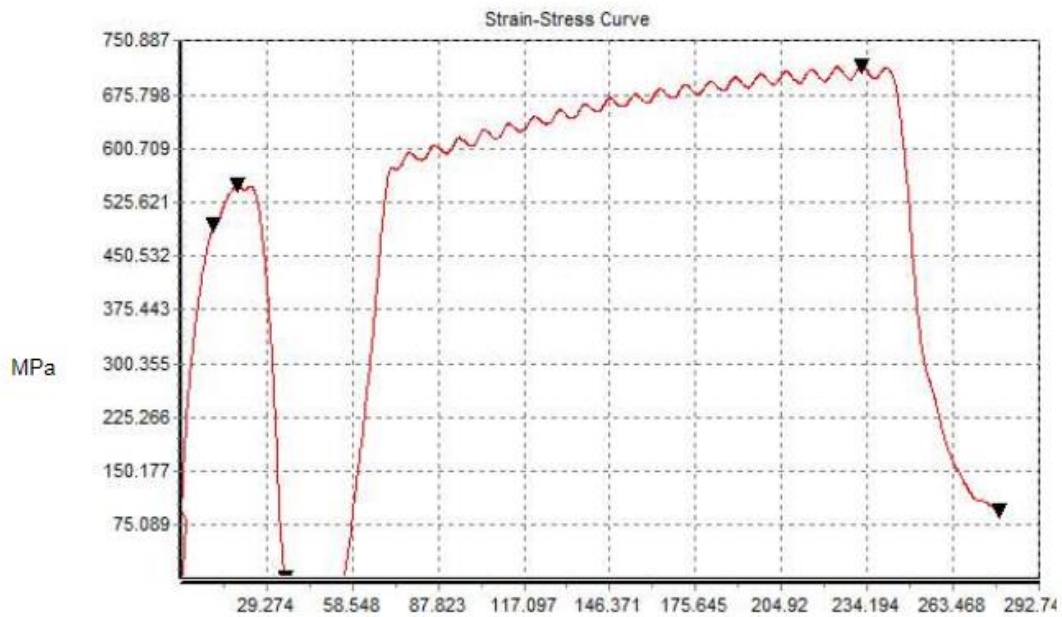



Figure 3.6: Torsion testing machine NDW 500



Figure 3.9 Die ECAP Process after one pass



Figure 3.10: 300 mm length and circler base with 16 mm diameter Copper



Figure 3.11: Two Specimen with 53.23 mm and 36 mm length for torsion test



Figure 3.12: CNC Lathe Machine



Figure 3.13: CNC Milling Machine



Figure 3.14: 2 passes Nanostructure Titanium with scale



Figure 3.15: 4 passes Nanostructure Titanium 50 mm length, 22 mm Diameter



Figure 3.18: Titanium specimens with different stages scale

Appendix D

No.	Field name	Meaning
1	TabellID	Table No.
2	ID	Specimen No.
3	FID	Furnace No.
4	d	Diameter/ thickness
5	a	Width
6	W	Section coefficient
7	Ip	Polar moment of inertia
8	Lo	Gauge length of specimen
9	Lc	Parallel length of specimen
10	TestDate	Test date
11	Tester	Tester
12	TeH	Upper yield torque
13	reH	Upper yield force
14	TeL	Lower yield torque
15	reL	Lower yield strength
17	Tm	Max. torque
18	rm	Anti-torque strength
19	Tp	Fixed non-proportional torque
20	rp	Fixed non-proportional torque

WDW-10 Computer Controlled Electromechanical Universal Testing Machine

		strength
23	Tb	Fracture point torque
24	τ_b	Fracture point strength
	ϕ_b	Fracture point torsion angle
	Tt	Fixed total torsion torque
	τ_t	Fixed torsion strength
25	G	Shear modulus
26	T1	Calculate the first point of shear modulus by two point means
27	T2	Calculate the second point of shear modulus by two point means
28	γ_{max}	Max. non-proportional shear strain
29	γ_{gt}	Max.torque shear strain
30	RelRe	Upper yield force vs. lower yield force
34	Le	Troptometer gauge
35	Tp2	The second fixed non-proportional torque
36	τ_{p2}	The second fixed non-proportional torsion strength
37	Tt2	The second Tt
38	τ_{t2}	The second τ_t
39	τ_{m_i}	Not rounded τ_m
40	τ_{eH_i}	Not rounded τ_{eH}
41	τ_{eL_i}	Not rounded τ_{eL}

WDW-10 Computer Controlled Electromechanical Universal Testing Machine

42	τp_i	Not rounded τp
43	τt_i	Not rounded τt
44	τb_i	Not rounded τb
48	$\tau p2_i$	Not rounded $\tau p2$
49	$\tau t2_i$	Not rounded $\tau t2$
50	Comment	Comment
51	xAxis	X Axis
52	yAxis	Y Axis
53	Spec	Specification
54	Grade	Grade
55	Type	Type
56	Temperature	Temperature
57	p1	The first suffix of Rp
58	t1	The first suffix of Rt
59	p2	The second suffix of Rp
60	t2	The second suffix of Rt
61	Bend	Bend
62	Rebend	Rebend
63	JBS	Jointing breaking state
64	JBP	Jointing breaking position
65	MML	Mother material length
66	MMW	Mother material weight

Model Information

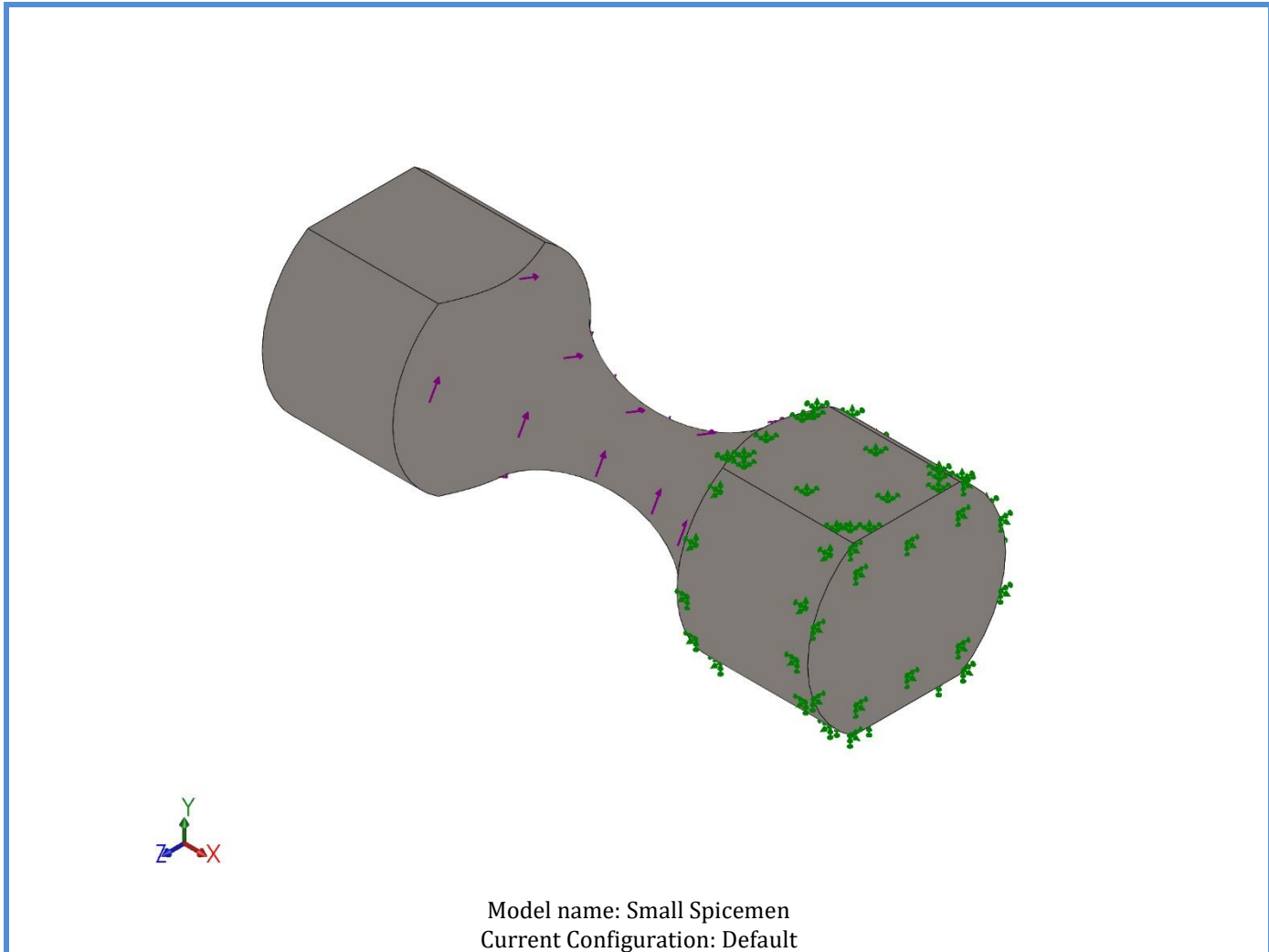

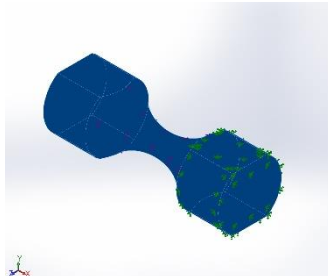
Solid Bodies			
Document Name and Reference	Treated As	Volumetric Properties	Document Path/Date Modified
Cut-Extrude1 	Solid Body	Mass:0.0121586 kg Volume:2.69591e-006 m ³ Density:4510 kg/m ³ Weight:0.119154 N	C:\Users\Masoud\Desktop \pmu\assiment 3\New folder\الجاهز\solid works\Small Spicemen- torsion1\Ti\New folder\Small Spicemen.SLDPRT

Study Properties

Study name	torsion1
Analysis type	Static
Mesh type	Solid Mesh
Thermal Effect:	On
Thermal option	Include temperature loads
Zero strain temperature	298 Kelvin
Include fluid pressure effects from SOLIDWORKS Flow Simulation	Off
Solver type	FFEPlus
Inplane Effect:	Off
Soft Spring:	Off
Inertial Relief:	Off
Incompatible bonding options	Automatic
Large displacement	Off
Compute free body forces	On
Friction	Off
Use Adaptive Method:	Off
Result folder	SOLIDWORKS document (C:\Users\Masoud\Desktop\pmu\assiment 3\New folder\الجاهز\solid works)

Units

Unit system:	SI (MKS)
Length/Displacement	mm
Temperature	Kelvin
Angular velocity	Rad/sec
Pressure/Stress	N/m ²

Material Properties

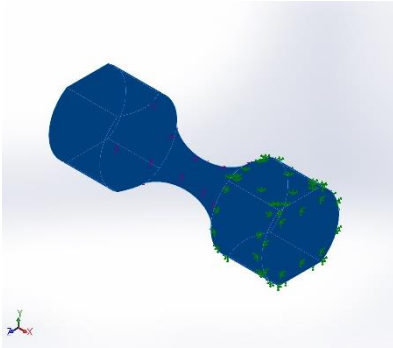
Model Reference	Properties	Components
	Name: Commercially Pure CP-Ti UNS R50700 Grade 4 (SS) Model type: Linear Elastic Isotropic Default failure criterion: Unknown Yield strength: 5e+008 N/m² Tensile strength: 5.5e+008 N/m² Elastic modulus: 1.05e+011 N/m² Poisson's ratio: 0.37 Mass density: 4510 kg/m³ Shear modulus: 4.5e+010 N/m² Thermal expansion coefficient: 9e-006 /Kelvin	SolidBody 1(Cut-Extrude1)(Small Spicemen)
Curve Data:N/A		

Loads and Fixtures

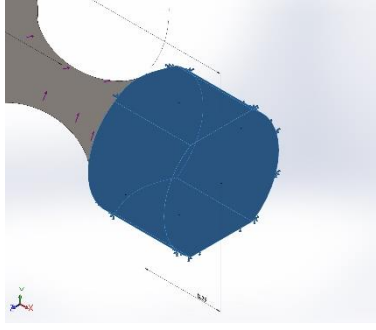
Fixture name	Fixture Image	Fixture Details		
Fixed-1		Entities: 5 face(s) Type: Fixed Geometry		
Resultant Forces				
Components	X	Y	Z	Resultant
Reaction force(N)	0.00104356	0.00244939	-0.00126117	0.00294603
Reaction Moment(N.m)	0	0	0	0

Load name	Load Image	Load Details
-----------	------------	--------------

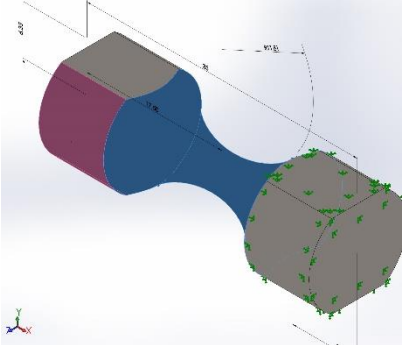
Torque-1		<p>Entities: 1 face(s) Reference: Face< 1 > Type: Apply torque Value: 5 N.m</p>
----------	---	--

Mesh information

Mesh type	Solid Mesh
Mesher Used:	Standard mesh
Automatic Transition:	Off
Include Mesh Auto Loops:	On
Jacobian points	4 Points
Element Size	0.169173 mm
Tolerance	1.065e-005 mm
Mesh Quality	High

Mesh information - Details

Total Nodes	2106341
Total Elements	1512166
Maximum Aspect Ratio	28.659
% of elements with Aspect Ratio < 3	99.9
% of elements with Aspect Ratio > 10	0.00245
% of distorted elements(Jacobian)	0
Time to complete mesh(hh:mm:ss):	00:01:35
Computer name:	MASOUD

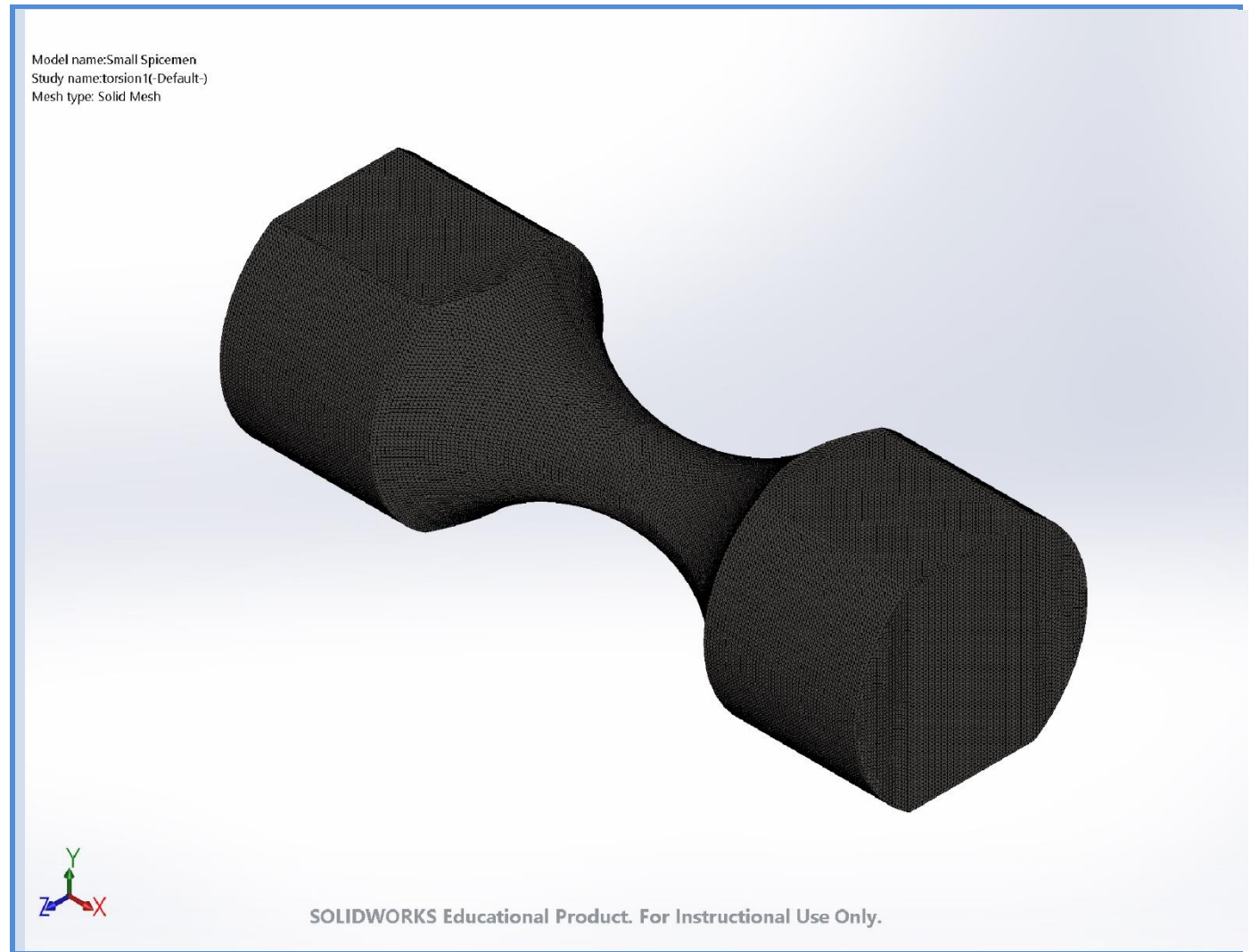

Study Results

Name	Type	Min	Max
Stress1	VON: von Mises Stress	0.0113238 N/m ² Node: 2032301	3.307e+008 N/m ² Node: 5513

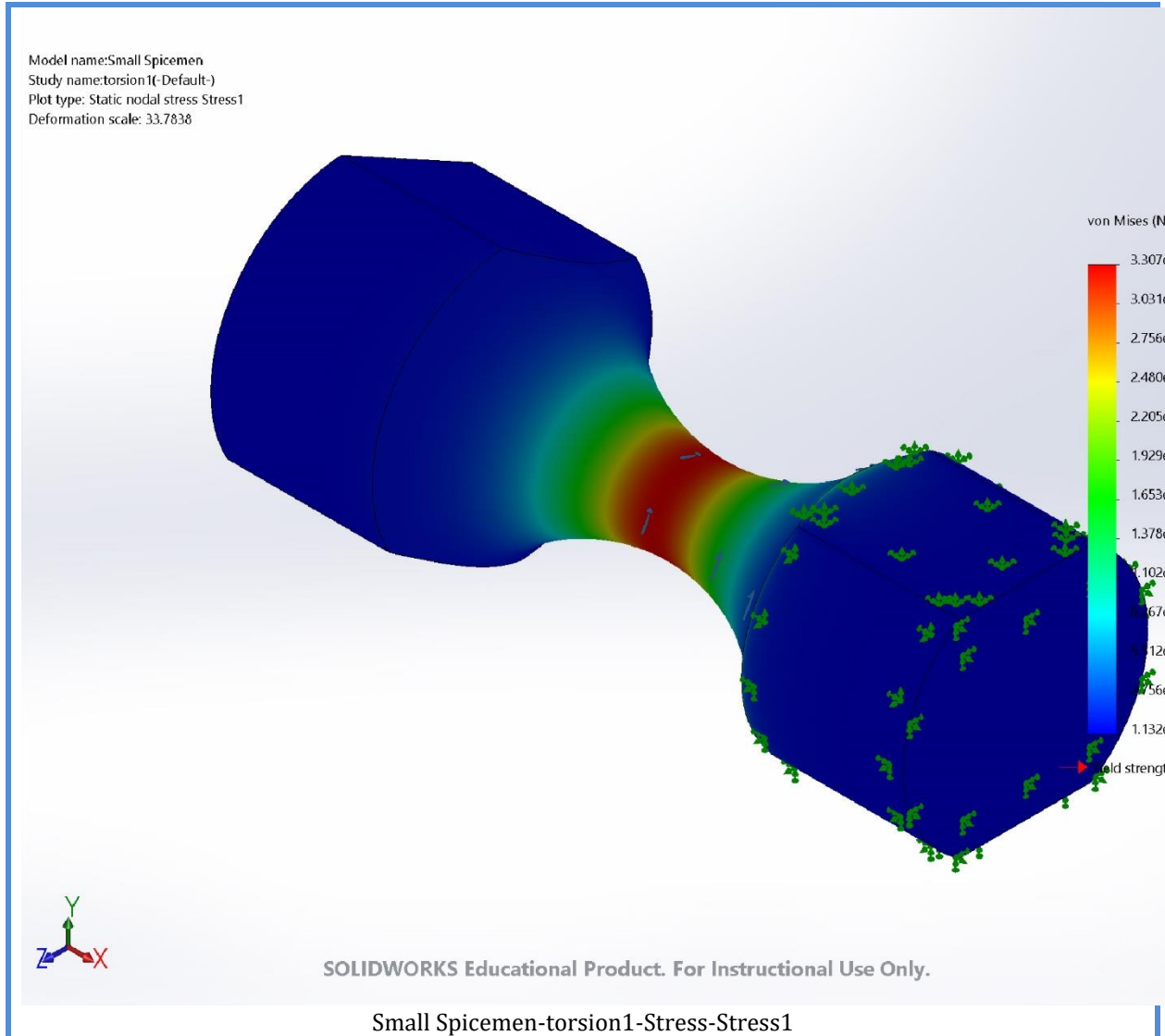

Name	Type	Min	Max
Displacement1	URES: Resultant Displacement	0 mm Node: 163	0.1036 mm Node: 5209

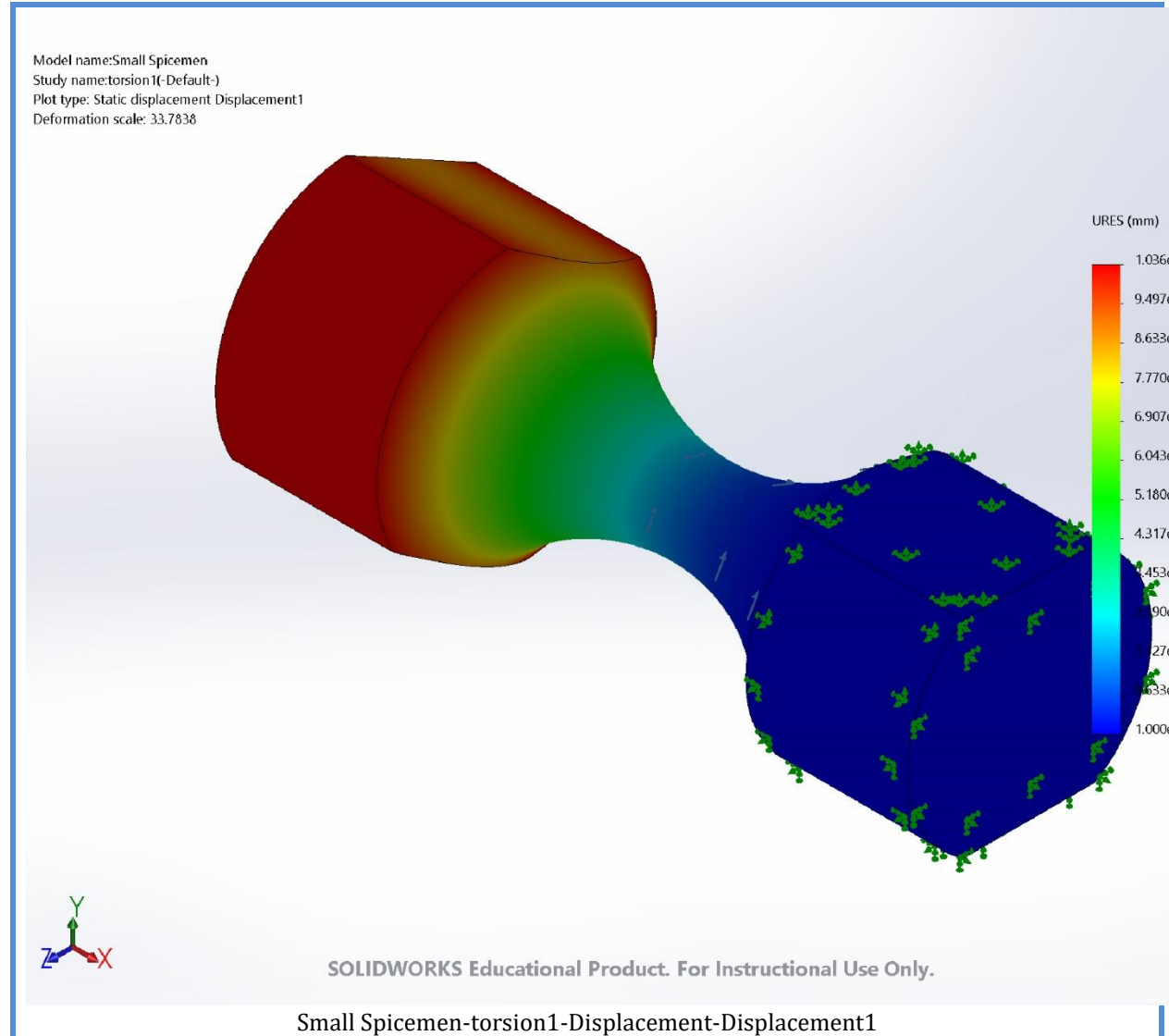

Name	Type	Min	Max
Strain1	ESTRN: Equivalent Strain	1.11899e-008 Element: 136750	0.00283716 Element: 47419

Model name: Small Spicemen
Study name: torsion1 (- Default)
Plot type: Static strain Strain1
Deformation scale: 33.7838

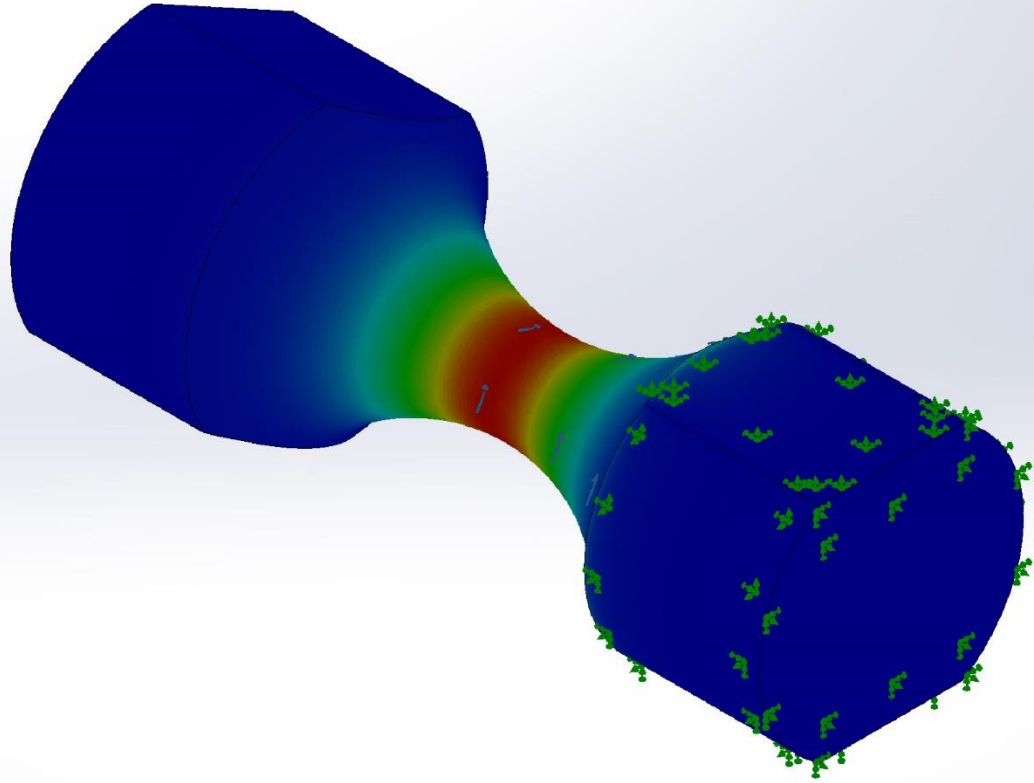

SOLIDWORKS Educational Product. For Instructional Use Only.

Small Spicemen-torsion1-Strain-Strain1

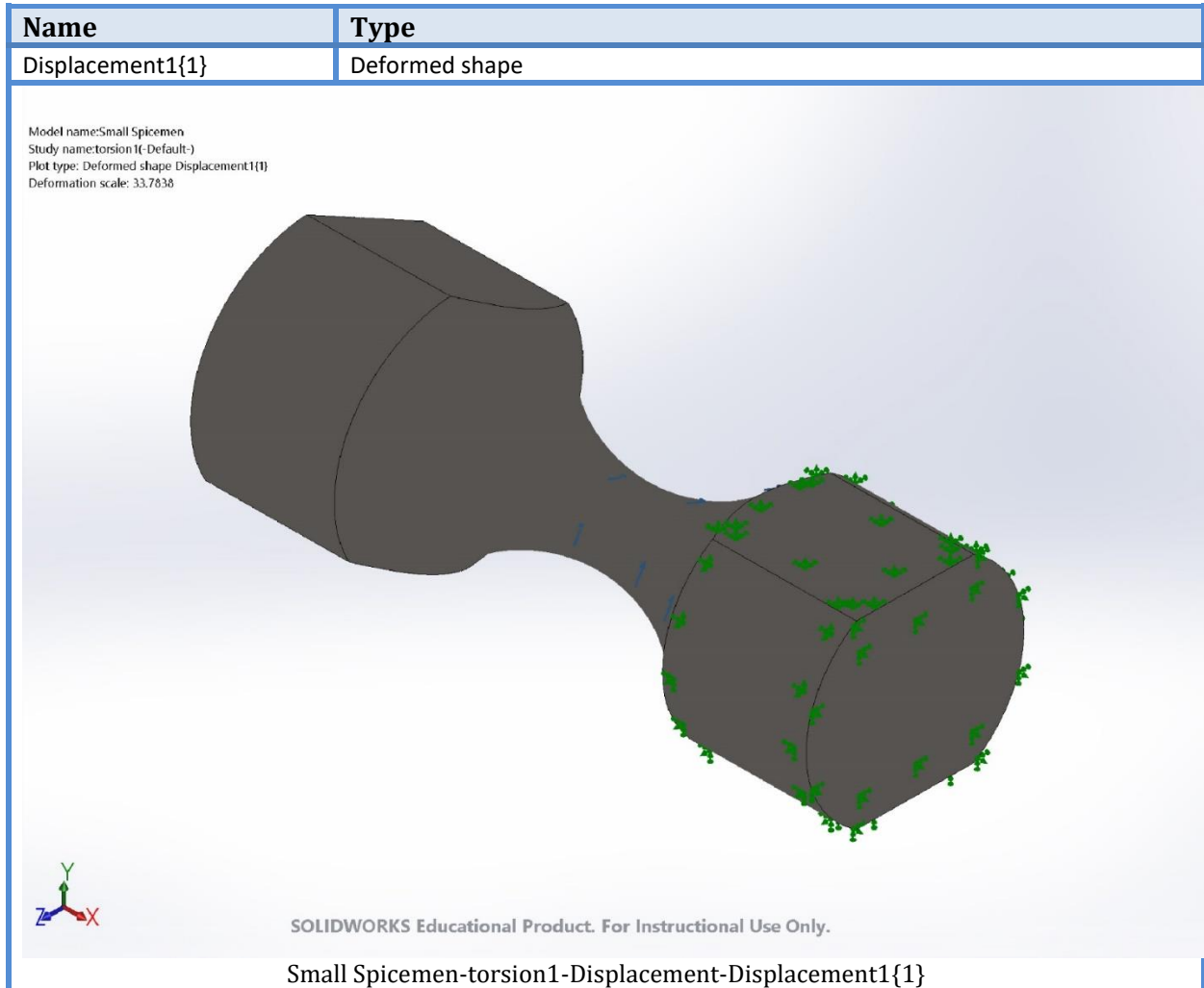

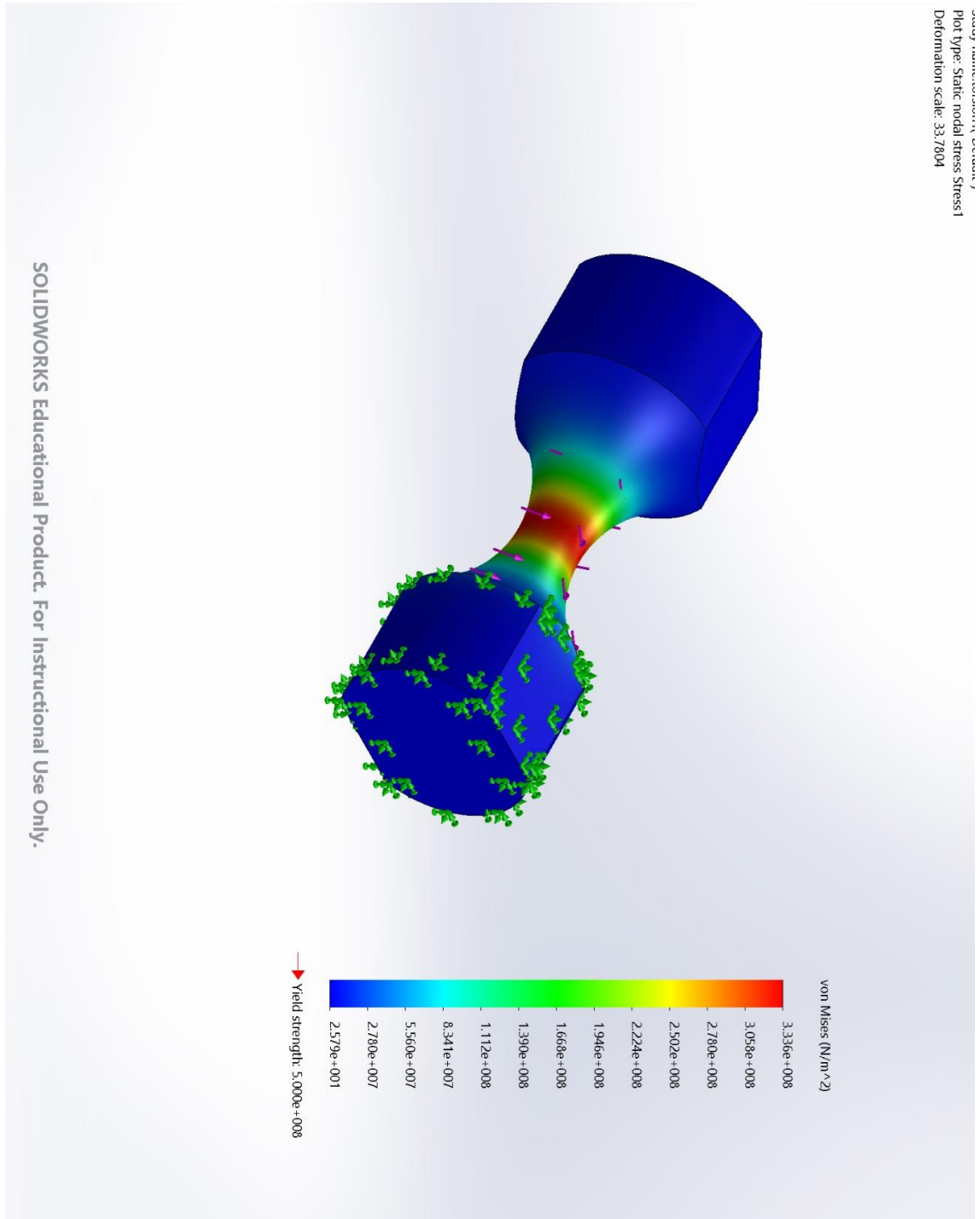

Image-1

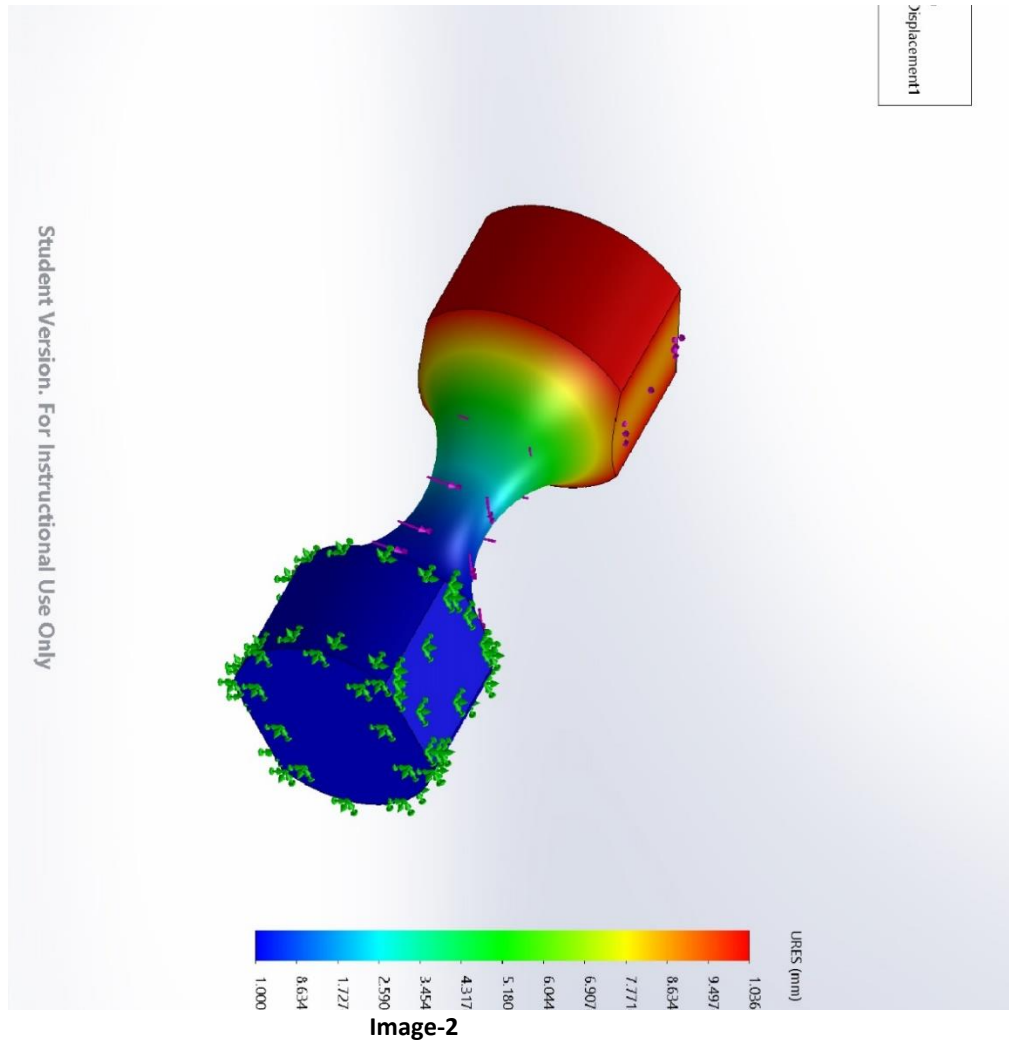

Image-2

Project

First Saved	Sunday, May 28, 2017
Last Saved	Wednesday, May 31, 2017
Product Version	18.1 Release
Save Project Before Solution	No
Save Project After Solution	No

Contents

- [Units](#)
- [Model \(B4\)](#)
 - [Geometry](#)
 - [Geom/Solid1](#)
 - [Coordinate Systems](#)
 - [Mesh](#)
 - [Static Structural \(B5\)](#)
 - [Analysis Settings](#)
 - [Loads](#)
 - [Solution \(B6\)](#)
 - [Solution Information](#)
 - [Results](#)
- [Material Data](#)
 - [Titanium Alloy](#)

Report Not Finalized

Not all objects described below are in a finalized state. As a result, data may be incomplete, obsolete or in error. View first state problem. To finalize this report, edit objects as needed and solve the analyses.

Units

TABLE 1

Unit System	Metric (mm, kg, N, s, mV, mA) Degrees rad/s Celsius
Angle	Degrees
Rotational Velocity	rad/s
Temperature	Celsius

Model (B4)

Geometry

TABLE 2
Model (B4) > Geometry

Object Name	<i>Geometry</i>
State	Fully Defined
Definition	
Source	C:\Users\Fluid Codes\Desktop\Project\tianiumtest_files\dp0\Geom\DM\Geom.scdoc

Type	SpaceClaim
Length Unit	Meters
Element Control	Program Controlled
Display Style	Body Color
Bounding Box	
Length X	35. mm
Length Y	10.716 mm
Length Z	12.7 mm
Properties	
Volume	2696. mm ³
Mass	1.2164e-002 kg
Scale Factor Value	1.
Statistics	
Bodies	1
Active Bodies	1
Nodes	2768929
Elements	676818
Mesh Metric	None
Basic Geometry Options	
Solid Bodies	Yes
Surface Bodies	Yes
Line Bodies	Yes
Parameters	Independent
Parameter Key	
Attributes	Yes

Attribute Key	
Named Selections	Yes
Named Selection Key	
Material Properties	Yes
Advanced Geometry Options	
Use Associativity	Yes
Coordinate Systems	Yes
Coordinate System Key	
Reader Mode Saves Updated File	No
Use Instances	Yes
Smart CAD Update	Yes
Compare Parts On Update	No
Attach File Via Temp File	Yes
Temporary Directory	C:\Users\Fluid Codes\AppData\Local\Temp
Analysis Type	3-D
Mixed Import Resolution	None
Decompose Disjoint Geometry	Yes
Enclosure and Symmetry Processing	Yes

TABLE 3
Model (B4) > Geometry > Parts

Object Name	<i>Geom\Solid1</i>
State	Meshed
Graphics Properties	
Visible	Yes

Transparency	1
Definition	
Suppressed	No
Stiffness Behavior	Flexible
Coordinate System	Default Coordinate System
Reference Temperature	By Environment
Behavior	None
Material	
Assignment	Titanium Alloy
Nonlinear Effects	Yes
Thermal Strain Effects	Yes
Bounding Box	
Length X	35. mm
Length Y	10.716 mm
Length Z	12.7 mm
Properties	
Volume	2696. mm ³
Mass	1.2164e-002 kg
Centroid X	2.6845e-006 mm
Centroid Y	2.3345 mm
Centroid Z	-1.9278e-004 mm
Moment of Inertia Ip1	0.20035 kg·mm ²
Moment of Inertia Ip2	1.8853 kg·mm ²
Moment of Inertia Ip3	1.8629 kg·mm ²
Statistics	

Nodes	2768929
Elements	676818
Mesh Metric	None
CAD Attributes	
PartTolerance:	0.00000001
Color:175.156.143	

Coordinate Systems

TABLE 4
Model (B4) > Coordinate Systems > Coordinate System

Object Name	<i>Global Coordinate System</i>
State	Fully Defined
Definition	
Type	Cartesian
Coordinate System ID	0.
Origin	
Origin X	0. mm
Origin Y	0. mm
Origin Z	0. mm
Directional Vectors	
X Axis Data	[1. 0. 0.]
Y Axis Data	[0. 1. 0.]
Z Axis Data	[0. 0. 1.]

Mesh

TABLE 5
Model (B4) > Mesh

Object Name	<i>Mesh</i>
State	Solved

Display	
Display Style	Body Color
Defaults	
Physics Preference	Mechanical
Relevance	0
Element Order	Program Controlled
Sizing	
Size Function	Adaptive
Relevance Center	Fine
Element Size	0.20 mm
Initial Size Seed	Assembly
Transition	Fast
Span Angle Center	Fine
Automatic Mesh Based Defeaturing	On
Defeature Size	Default
Minimum Edge Length	6.84110 mm
Quality	
Check Mesh Quality	Yes, Errors
Error Limits	Standard Mechanical
Target Quality	Default (0.050000)
Smoothing	Medium
Mesh Metric	None
Inflation	
Use Automatic Inflation	None
Inflation Option	Smooth Transition

Transition Ratio	0.272
Maximum Layers	5
Growth Rate	1.2
Inflation Algorithm	Pre
View Advanced Options	No
Advanced	
Number of CPUs for Parallel Part Meshing	Program Controlled
Straight Sided Elements	No
Number of Retries	Default (4)
Rigid Body Behavior	Dimensionally Reduced
Mesh Morphing	Disabled
Triangle Surface Mesher	Program Controlled
Topology Checking	No
Pinch Tolerance	Please Define
Generate Pinch on Refresh	No
Statistics	
Nodes	2768929
Elements	676818

Static Structural (B5)

TABLE 6
Model (B4) > Analysis

Object Name	<i>Static Structural (B5)</i>
State	Solved
Definition	
Physics Type	Structural
Analysis Type	Static Structural

Solver Target	Mechanical APDL
Options	
Environment Temperature	22. °C
Generate Input Only	No

TABLE 7
Model (B4) > Static Structural (B5) > Analysis Settings

Object Name	<i>Analysis Settings</i>
State	Fully Defined
Step Controls	
Number Of Steps	1.
Current Step Number	1.
Step End Time	1. s
Auto Time Stepping	Program Controlled
Solver Controls	
Solver Type	Program Controlled
Weak Springs	Off
Solver Pivot Checking	Program Controlled
Large Deflection	Off
Inertia Relief	Off
Rotordynamics Controls	
Coriolis Effect	Off
Restart Controls	
Generate Restart Points	Program Controlled
Retain Files After Full Solve	No
Combined Restart Files	Program Controlled
Nonlinear Controls	

Newton-Raphson Option	Program Controlled
Force Convergence	Program Controlled
Moment Convergence	Program Controlled
Displacement Convergence	Program Controlled
Rotation Convergence	Program Controlled
Line Search	Program Controlled
Stabilization	Off
Output Controls	
Stress	Yes
Strain	Yes
Nodal Forces	No
Contact Miscellaneous	No
General Miscellaneous	No
Store Results At	All Time Points
Analysis Data Management	
Solver Files Directory	C:\Users\Fluid Codes\Desktop\Project\taniumtest_files\dp0\SYS\MECH\
Future Analysis	None
Scratch Solver Files Directory	
Save MAPDL db	No
Delete Unneeded Files	Yes
Nonlinear Solution	No
Solver Units	Active System
Solver Unit System	nmm

TABLE 8
Model (B4) > Static Structural (B5) > Loads

Object Name	<i>Fixed Support</i>	<i>Moment</i>
-------------	----------------------	---------------

State	Fully Defined	
Scope		
Scoping Method	Geometry Selection	
Geometry	1 Face	
Definition		
Type	Fixed Support	Moment
Suppressed	No	
Define By		Vector
Magnitude		8450. N-mm (ramped)
Direction		Defined
Behavior		Deformable
Advanced		
Pinball Region		All

FIGURE 1
Model (B4) > Static Structural (B5) > Moment

Solution (B6)

TABLE 9
Model (B4) > Static Structural (B5) > Solution

Object Name	<i>Solution (B6)</i>
State	Solved
Adaptive Mesh Refinement	
Max Refinement Loops	1.
Refinement Depth	2.
Information	
Status	Done
MAPDL Elapsed Time	11 m 36 s

MAPDL Memory Used	12.048 GB
MAPDL Result File Size	921.63 MB
Post Processing	
Beam Section Results	No

TABLE 10
Model (B4) > Static Structural (B5) > Solution (B6) > Solution Information

Object Name	<i>Solution Information</i>
State	Solved
Solution Information	
Solution Output	Solver Output
Newton-Raphson Residuals	0
Identify Element Violations	0
Update Interval	2.5 s
Display Points	All
FE Connection Visibility	
Activate Visibility	Yes
Display	All FE Connectors
Draw Connections Attached To	All Nodes
Line Color	Connection Type
Visible on Results	No
Line Thickness	Single
Display Type	Lines

TABLE 11
Model (B4) > Static Structural (B5) > Solution (B6) > Results

Object Name	<i>Maximum Principal Stress</i>	<i>Maximum Principal Elastic Strain</i>	<i>Shear Stress</i>
State	Solved		

Scope			
Scoping Method	Geometry Selection		
Geometry	All Bodies		
Definition			
Type	Maximum Principal Stress	Maximum Principal Elastic Strain	Shear Stress
By	Time		
Display Time	Last		
Calculate Time History	Yes		
Identifier			
Suppressed	No		
Orientation			XY Plane
Coordinate System			Global Coordinate System
Integration Point Results			
Display Option	Averaged		
Average Across Bodies	No		
Results			
Minimum	-16.417 MPa	2.7986e-003 mm/mm	-642.34 MPa
Maximum	643.15 MPa	8.5197 mm/mm	642.28 MPa
Minimum Occurs On	Geom\Solid1		
Maximum Occurs On	Geom\Solid1		
Information			
Time	1. s		
Load Step	1		

Substep	1
Iteration Number	1

FIGURE 2
Model (B4) > Static Structural (B5) > Solution (B6) > Maximum Principal Stress

TABLE 12
Model (B4) > Static Structural (B5) > Solution (B6) > Maximum Principal Stress

Time [s]	Minimum [MPa]	Maximum [MPa]
1.	-16.417	643.15

FIGURE 3
Model (B4) > Static Structural (B5) > Solution (B6) > Maximum Principal Stress > Figure

FIGURE 4
Model (B4) > Static Structural (B5) > Solution (B6) > Maximum Principal Elastic Strain

TABLE 13
Model (B4) > Static Structural (B5) > Solution (B6) > Maximum Principal Elastic Strain

Time [s]	Minimum [mm/mm]	Maximum [mm/mm]
1.	2.7986e-003	8.5197

FIGURE 5
Model (B4) > Static Structural (B5) > Solution (B6) > Maximum Principal Elastic Strain > Figure

FIGURE 6
Model (B4) > Static Structural (B5) > Solution (B6) > Shear Stress

TABLE 14
Model (B4) > Static Structural (B5) > Solution (B6) > Shear Stress

Time [s]	Minimum [MPa]	Maximum [MPa]
1.	-642.34	642.28

FIGURE 7
Model (B4) > Static Structural (B5) > Solution (B6) > Shear Stress > Figure

Material Data

Titanium Alloy

TABLE 15
Titanium Alloy > Constants

Density	4.512e-006 kg mm ⁻³
Isotropic Secant Coefficient of Thermal Expansion	9.4e-006 C ⁻¹
Specific Heat	5.22e+005 mJ kg ⁻¹ C ⁻¹
Isotropic Thermal Conductivity	2.19e-002 W mm ⁻¹ C ⁻¹
Isotropic Resistivity	1.7e-003 ohm mm

TABLE 16
Titanium Alloy > Appearance

Red	Green	Blue
88	72	117

TABLE 17
Titanium Alloy > Compressive Ultimate Strength

Compressive Ultimate Strength MPa
0

TABLE 18
Titanium Alloy > Compressive Yield Strength

Compressive Yield Strength MPa
930

TABLE 19
Titanium Alloy > Tensile Yield Strength

Tensile Yield Strength MPa
480

TABLE 20
Titanium Alloy > Tensile Ultimate Strength

Tensile Ultimate Strength MPa
550

TABLE 21
Titanium Alloy > Isotropic Secant Coefficient of Thermal Expansion

Zero-Thermal-Strain Reference Temperature C
22

TABLE 22
Titanium Alloy > Isotropic Elasticity

Temperature C	Young's Modulus MPa	Poisson's Ratio	Bulk Modulus MPa	Shear Modulus MPa
	103.42	0.37	132.59	37.745

TABLE 23
Titanium Alloy > Isotropic Relative Permeability

Relative Permeability
1

Torque	Stress	Strain	Shear Stress
500	38.05641	0.504125	38.00488853
1000	76.11282	1.008249	76.00977707
1500	114.1692	1.512374	114.0146637
2000	152.2256	2.016499	152.0195541
2500	190.282	2.520623	190.024437
3000	228.3384	3.024748	228.0293274
3500	266.3948	3.528873	266.0342102
4000	304.4513	4.032998	304.0391083
4500	342.5077	4.537122	342.0439758
5000	380.5641	5.041247	380.0488739
5500	418.6205	5.545372	418.0537567
6000	456.6769	6.049496	456.0586548
6500	494.7333	6.553621	494.0635376
7000	532.7896	7.057746	532.0684204
7500	570.8461	7.56187	570.0733032
8000	608.9025	8.065995	608.0782166
8450	643.1532	8.519707	642.2826233
8500	646.9589	8.57012	646.0830841
9000	685.0153	9.074244	684.0879517

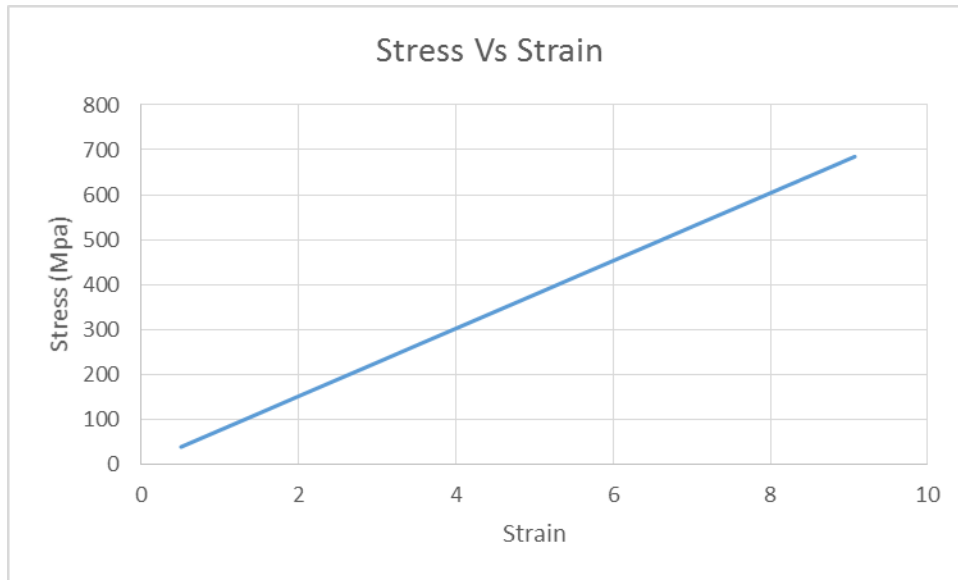

TITANIUM Grade 1

Commercial pure titanium

The data given is for information not for design

Chemical composition (weight %) (Maximum values unless range is shown)										
O	N	C	H	Fe	Al	V	Ni	Mo	Others	Residuals
0.18	0.03	0.08	0.015	0.2						0.4

Unalloyed titanium offering optimum ductility and cold formability with useful strength, high-impact toughness, and excellent weldability. Highly corrosion resistant in oxidizing and mildly reducing environments, including chlorides.

Mechanical properties at room temperature		
	Minimum values	Typical values
Yield Strength	170 MPa	220 MPa
Ultimate Strength	240 MPa	345 MPa
Elongation in 50 mm, A5	25 %	37 %
Reduction in Area	30 %	%
Hardness		115 HV
Modulus of elasticity		103 GPa
Charpy V-Notch Impact		95-162 J

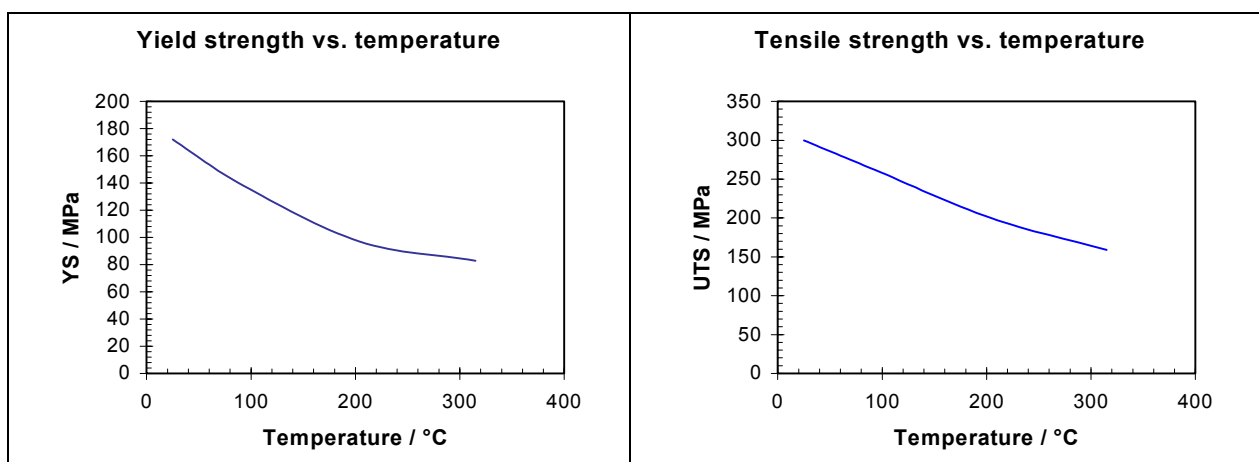

Fatigue properties at room temperature (Stress to cause failure in 10^7 Cycles)		
Rotating bend		
Smooth	$K_t=1$	193 MPa
Notch	$K_t=3$	123 MPa

Physical properties	
Melting point, ± 15 °C	1670 °C
Density	4.51 g/cm ³
Beta transus, ± 15 °C	890 °C
Thermal expansion, 20 - 100 °C	$8.6 \cdot 10^{-6} \text{ K}^{-1}$
Thermal expansion, 0 - 300 °C	$9.2 \cdot 10^{-6} \text{ K}^{-1}$
Thermal conductivity, room temperature	20.8 W/mK
Thermal conductivity, 400 °C	14 W/mK
Specific heat, room temperature	0.56 J/gK
Specific heat, 400 °C	0.60 J/gK
Electrical resistivity, room temperature	52 $\mu\text{W}\cdot\text{cm}$
Poisson's ratio	0.34-0.40

Heat treating			
		Temperature	Time
Annealing	air-cooled	650-760 °C	6 min - 2 hours
Stress relieving	air-cooled	480-595 °C	15 min - 4 hours

Weldability – excellent

Grade 1 has very good weldability. Being substantially single-phase material, the microstructure of the alpha phase is not affected greatly by thermal treatments or welding temperatures. Therefore, the mechanical properties of a correctly welded joint are equal to, or exceed those of the parent metal and show good ductility

Available mill products

Bar, billet, ingot, extrusions, plate, sheet, strip, tubing, wire, pipe, forging

Typical Applications

For corrosion resistance in the chemical and marine industries; in airframe construction where maximum ease of formability is desired

Industry specifications	ASTM Gradel, JIS Grade , TIA, RMI 25, TIMETAL 35A, ST-40
Sheet and plate	ASTM B265 Gr1, Mil-T-9046 CP-4
Bars and billets	ASTM B348 Gr1
Tube	ASTM B337 Gr1, ASTM B338 Gr1
Forging	ASTM B381 Gr1
Casting	ASTM F467 Gr1 ASTM F468 Gr1 DIN 3.7025 BSTA 1

TITANIUM Grade 2

Commercial pure titanium

The data given is for information not for design

Chemical composition (weight %) (Maximum values unless range is shown)										
O	N	C	H	Fe	Al	V	Ni	Mo	Others	Residuals
0.25	0.03	0.08	0.015	0.3						0.4

Grade 2 is the most widely used titanium alloy in all product forms for industrial service, offering an excellent balance of moderate strength and reasonable ductility. Highly corrosion-resistant in highly oxidizing and mildly reducing environments, including chlorides.

Mechanical properties at room temperature		
	Minimum values	Typical values
Yield Strength	275 MPa	350-450 MPa
Ultimate Strength	345 MPa	485 MPa
Elongation in 50 mm, A5	20 %	28 %
Reduction in Area	30 %	55 %
Hardness		160-200 HV
Modulus of elasticity		103 GPa
Charpy V-Notch Impact		40-82 J

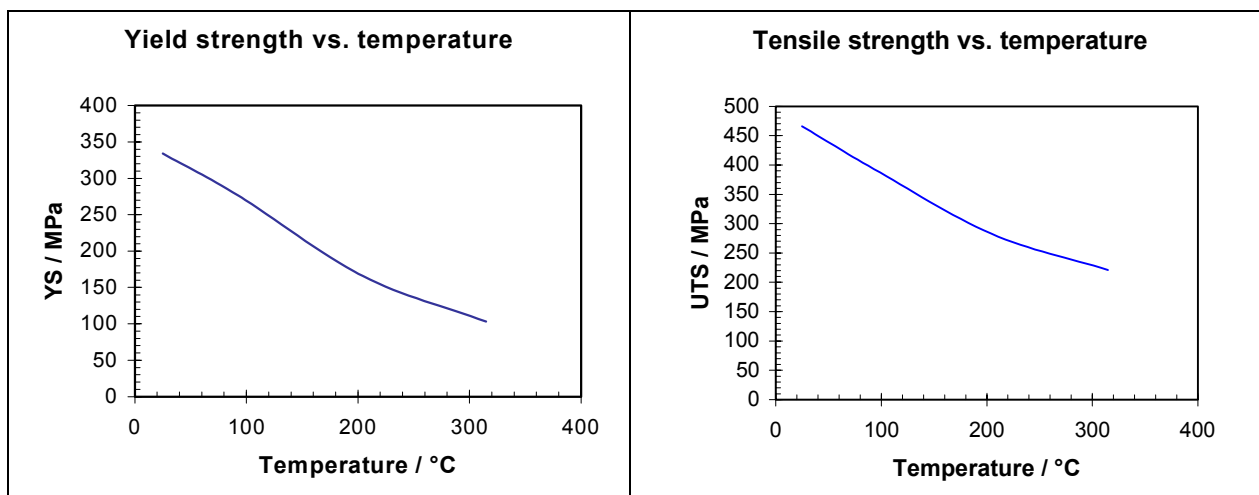

Fatigue properties at room temperature (Stress to cause failure in 10^7 Cycles)		
Rotating bend		
Smooth	$K_t=1$	230 MPa
Notch	$K_t=3$	155 MPa

Physical properties	
Melting point, ± 15 °C	1660 °C
Density	4.51 g/cm ³
Beta transus, ± 15 °C	910 °C
Thermal expansion, 20 - 100 °C	$8.6 \cdot 10^{-6}$ K ⁻¹
Thermal expansion, 0 - 300 °C	$9.7 \cdot 10^{-6}$ K ⁻¹
Thermal conductivity, room temperature	20.8 W/mK
Thermal conductivity, 400 °C	15 W/mK
Specific heat, room temperature	0.52 J/gK
Specific heat, 400 °C	0.60 J/gK
Electrical resistivity, room temperature	56 μ W*cm
Poisson's ratio	0.34-0.40

Heat treating			
		Temperature	Time
Annealing	air-cooled	650-760 °C	6 min - 2 hours
Stress relieving	air-cooled	480-595 °C	15 min - 4 hours

Weldability – excellent

Grade 2 has very good weldability. Being substantially single phase material, the microstructure of the alpha phase is not affected greatly by thermal treatments or welding temperatures. Therefore, the mechanical properties of a correctly welded joint are equal to, or exceed those of the parent metal and show good ductility

Available mill products

Bar, billet, ingot, extrusions, plate, sheet, strip, tubing, wire, pipe, forging, casting

Typical Applications

For corrosion resistant in the chemical and offshore industries, in aircraft construction where a certain strength level and ease of formability is desired. Also used in heat exchangers, hypochlorite systems, fire water systems, ballast water systems, risers, fittings, flanges, fasteners, forgings, pumps, valves.

Industry specifications ASTM Grade 2, AMS 4902, JIS Grade 2, TIB, RMI 40, ST-50

Sheet and plate	ASTM B265 Gr2, MIL-T-9046 CP-3, AMS 4900
Bars and billets	ASTM B348 Gr2
Tube	ASTM B337 Gr2, ASTM B338 Gr2
Forging	ASTM B381 Gr2
Casting	ASTM B367 Gr2, ASTM F467 Gr2, ASTM F468 Gr2

TITANIUM Grade 3

Commercial pure titanium

The data given is for information not for design

Chemical composition (weight %) (Maximum values unless range is shown)										
O	N	C	H	Fe	Al	V	Ni	Mo	Others	Residuals
0.35	0.05	0.08	0.015	0.30						0.4

Unalloyed titanium offering optimum ductility and cold formability with useful strength, high-impact toughness, and excellent weldability. Highly corrosion resistant in oxidizing and mildly reducing environments, including chlorides.

Mechanical properties at room temperature		
	Minimum values	Typical values
Yield Strength	380 MPa	460 MPa
Ultimate Strength	450 MPa	595 MPa
Elongation in 50 mm, A5	18 %	25 %
Reduction in Area	30 %	%
Hardness		180-220 HV
Modulus of elasticity		103 GPa
Charpy V-Notch Impact		24-48 J

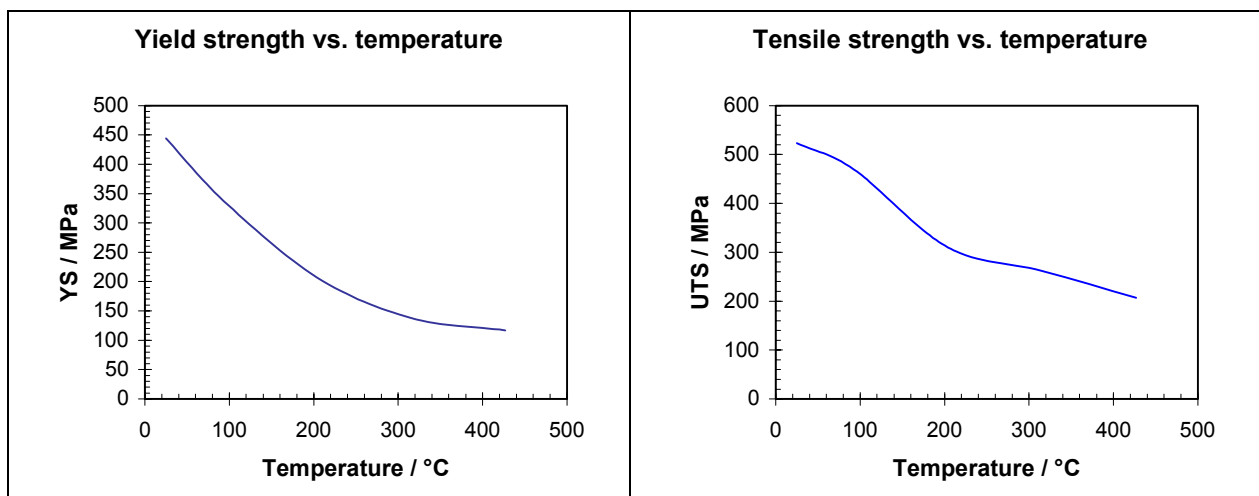

Fatigue properties at room temperature (Stress to cause failure in 10^7 Cycles)				
Rotating bend			Direct stress limit	
Smooth	$K_t=1$	380 MPa	Smooth	$K_t=1$ 280 MPa
Notch	$K_t=3$	165 MPa	Notch	$K_t=3$ 123 MPa

Physical properties	
Melting point, ± 15 °C	1680 °C
Density	4.51 g/cm ³
Beta transus, ± 15 °C	920 °C
Thermal expansion, 20 - 100 °C	8.6 *10 ⁻⁶ K ⁻¹
Thermal expansion, 0 - 300 °C	9.2 *10 ⁻⁶ K ⁻¹
Thermal conductivity, room temperature	17 W/mK
Thermal conductivity, 400 °C	16 W/mK
Specific heat, room temperature	0.54 J/gK
Specific heat, 400 °C	0.60 J/gK
Electrical resistivity, room temperature	56 μW*cm
Poisson's ratio	0.34-0.40

Heat treating				
		Temperature	Time	
Annealing	air-cooled	650-760 °C	6 min -	2 hours
Stress relieving	air-cooled	480-595 °C	15 min -	4 hours

Weldability – excellent

Grade 3 has very good weldability. Being substantially single phase material, the microstructure of the alpha phase is not affected greatly by thermal treatments or welding temperatures. Therefore, the mechanical properties of a correctly welded joint are equal to, or exceed those of the parent metal and show good ductility

Available mill products

Bar, billet, ingot, extrusions, plate, sheet, strip, tubing, wire, pipe, forging, casting

Typical Applications

Equivalent to Grade 1 and 2, and eminently suitable where high strength is needed

Industry specifications	ASTM Grade 3, AMS 4900, JIS Grade 3, TIC, RMI 55, ST-70
Sheet and plate	ASTM B265 Gr3, MIL-T-9046 CP-2, AMS 4900
Bars and billets	ASTM B348 Gr3
Tube	ASTM B337 Gr3, ASTM B338 Gr2
Forging	ASTM B381 Gr3
Casting	ASTM B367 Gr3, ASTM F467 Gr3 ASTM F468 Gr3, DIN 3.7055

TITANIUM Grade 4

Commercial pure titanium

The data given is for information not for design

Chemical composition (weight %) (Maximum values unless range is shown)										
O	N	C	H	Fe	Al	V	Ni	Mo	Others	Residuals
0.40	0.05	0.08	0.015	0.50						0.4

Unalloyed titanium offering reasonable high strength with good weldability. Good corrosion resistance in neutral to oxidizing environments, including chlorides.

Mechanical properties at room temperature		
	Minimum values	Typical values
Yield Strength	485 MPa	560 MPa
Ultimate Strength	550 MPa	685 MPa
Elongation in 50 mm, A5	15 %	23 %
Reduction in Area	30 %	%
Hardness		250 HV
Modulus of elasticity		104 GPa
Charpy V-Notch Impact		13-27 J

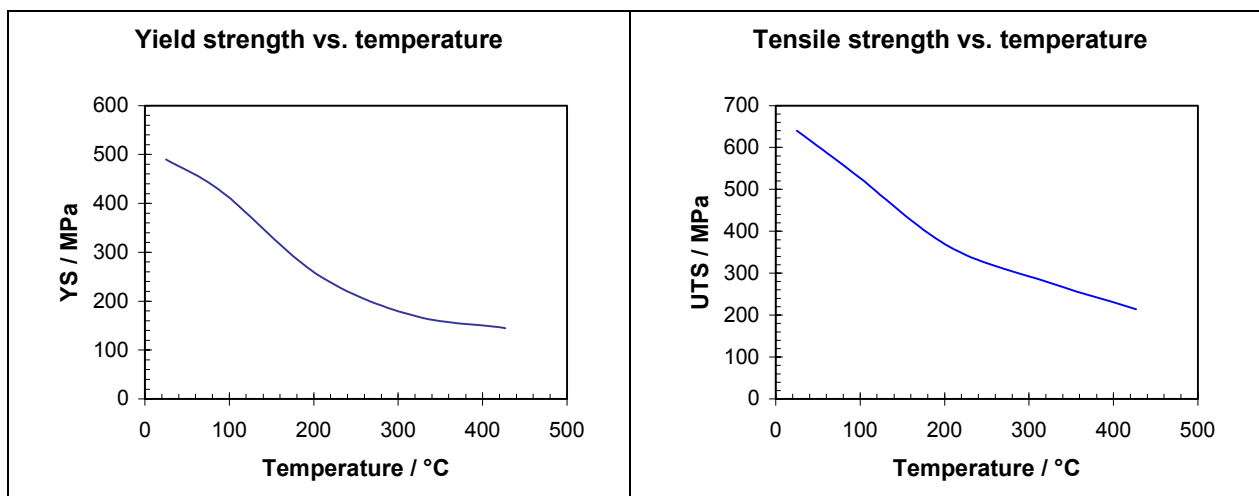

Fatigue properties at room temperature (Stress to cause failure in 10^7 Cycles)	
	Direct stress limit
	Smooth $K_t=1$ 375 MPa

Physical properties	
Melting point, ± 15 °C	1660 °C
Density	4.54 g/cm ³
Beta transus, ± 15 °C	950 °C
Thermal expansion, 20 - 100 °C	8.6 *10 ⁻⁶ K ⁻¹
Thermal expansion, 0 - 300 °C	9.2 *10 ⁻⁶ K ⁻¹
Thermal conductivity, room temperature	17.3 W/mK
Thermal conductivity, 400 °C	W/mK
Specific heat, room temperature	0.54 J/gK
Specific heat, 400 °C	0.40 J/gK
Electrical resistivity, room temperature	60 μW*cm
Poisson's ratio	0.34-0.40

Heat treating			
		Temperature	Time
Annealing	air-cooled	650-760 °C	6 min - 2 hours
Stress relieving	air-cooled	480-595 °C	6 min - hours

Weldability – excellent

Grade 4 has very good weldability. Being substantially single-phase material, the microstructure of the alpha phase is not affected greatly by thermal treatments or welding temperatures. Therefore, the mechanical properties of a correctly welded joint are equal to, or exceed those of the parent metal and show good ductility

Available mill products

Bar, billet, ingot, extrusions, plate, sheet, strip, tubing, wire, pipe, forging, casting

Typical Applications

For corrosion resistance in the chemical and marine industries and for aircraft construction

Industry specifications	ASTM Grade 4, JIS Grade 4, TID, RMI 70
Sheet and plate	AMS 4901, MIL-T-9046 CP-1
Bars and billets	ASTM B348 Gr4
Forging	ASTM B381 Gr4
Bar, forging and circular forging	AMS 4921
Bar, billet and forging blank	ASTM F467 Gr4, ASTM F468 Gr4
	DIN 3.7065
	BSTA 6,7,8,9

TITANIUM Grade 5

Ti - 6Al - 4V Alpha-beta alloy

The data given is for information not for design

Chemical composition (weight %) (Maximum values unless range is shown)										
O	N	C	H	Fe	Al	V	Ni	Mo	Others	Residuals
0.20	0.05	0.08	0.015	0.40	5.5-6.75	3.5-4.5				0.4

This is the most widely used titanium alloy. It has very high strength but relatively low ductility. The main application of this alloy is in aircraft and spacecraft. Offshore use is growing. The alloy is weldable and can be precipitation hardened.

Mechanical properties at room temperature		
	Minimum values	Typical values
Yield Strength	825 MPa	910 MPa
Ultimate Strength	895 MPa	1000 MPa
Elongation in 50 mm, A5	10 %	18 %
Reduction in Area	20 %	%
Hardness		330-390 HV
Modulus of elasticity		114 GPa
Charpy V-Notch Impact		20-27 J

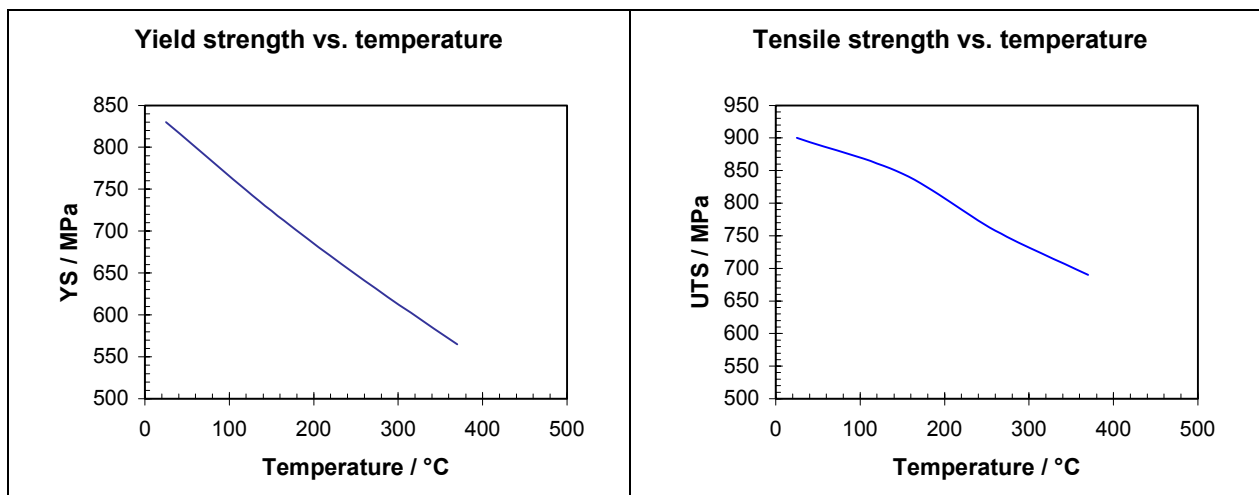

Fatigue properties at room temperature (Stress to cause failure in 10^7 Cycles)					
Rotating bend			Direct stress limit		
Smooth	$K_t=1$	430-520 MPa	Smooth	$K_t=1$	376 MPa
Notch	$K_t=3$	MPa	Notch	$K_t=3$	270 MPa

Physical properties	
Melting point, ± 15 °C	1650 °C
Density	4.43 g/cm ³
Beta transus, ± 15 °C	995 °C
Thermal expansion, 20 - 100 °C	$9.0 \cdot 10^{-6} \text{ K}^{-1}$
Thermal expansion, 0 - 300 °C	$9.5 \cdot 10^{-6} \text{ K}^{-1}$
Thermal conductivity, room temperature	6.6 W/mK
Thermal conductivity, 400 °C	13 W/mK
Specific heat, room temperature	0.57 J/gK
Specific heat, 400 °C	0.65 J/gK
Electrical resistivity, room temperature	171 $\mu\text{W}\cdot\text{cm}$
Poisson's ratio	0.30-0.33

Heat treating		
	Temperature	Time
Solution treating temperature	950-970°C	1 hour
Ageing temperature	480-595°C	4-8hours
Annealing	710-790°C	1-4hours
Stress relieving	480-650°C	1-4hours

Weldability – good

Since the two-phase microstructure of alpha-beta titanium alloys responds to thermal treatment, the temperatures encountered during the welding cycle can affect the material being welded.

Available mill products

Bar, billet, extrusions, plate, sheet, strip, wire

Typical Applications

Compressor blades, discs and rings for jet engines, aircraft components, pressure vessels, rocket engine cases, offshore pressure vessels.

Industry specifications

ASTM Grade5, ST-AI40, AMS4911D, MIL-T-9047G

Sheet and plate

ASTM B265 Gr5, AMS 4911

Bars and billets

ASTM B348 Gr5

Bars, billets and forging (+circular forging)

AMS 4928, AMS 4965, AMS 4967

Extruded products

AMS 4935

Castings

ASTM B367 Gr5

TITANIUM Grade 6

Ti-5Al-2.5Sn

The data given is for information not for design

Chemical composition (weight %) (Maximum values unless range is shown)										
O	N	C	H	Fe	Al	V	Sn	Mo	Others	Residuals
0.20	0.05	0.08	0.02	0.50	4.0-6.0		2.0-3.0			0.40

An alloy for airframe and jet engine applications requiring good weldability, stability and strength at elevated temperatures.

Mechanical properties at room temperature		
	Minimum values	Typical values
Yield Strength	795 MPa	900 MPa
Ultimate Strength	825 MPa	970 MPa
Elongation in 50 mm, A5	10 %	16 %
Reduction in Area	25 %	%
Hardness		330-350 HV
Modulus of elasticity		110 GPa
Charpy V-Notch Impact		14 J

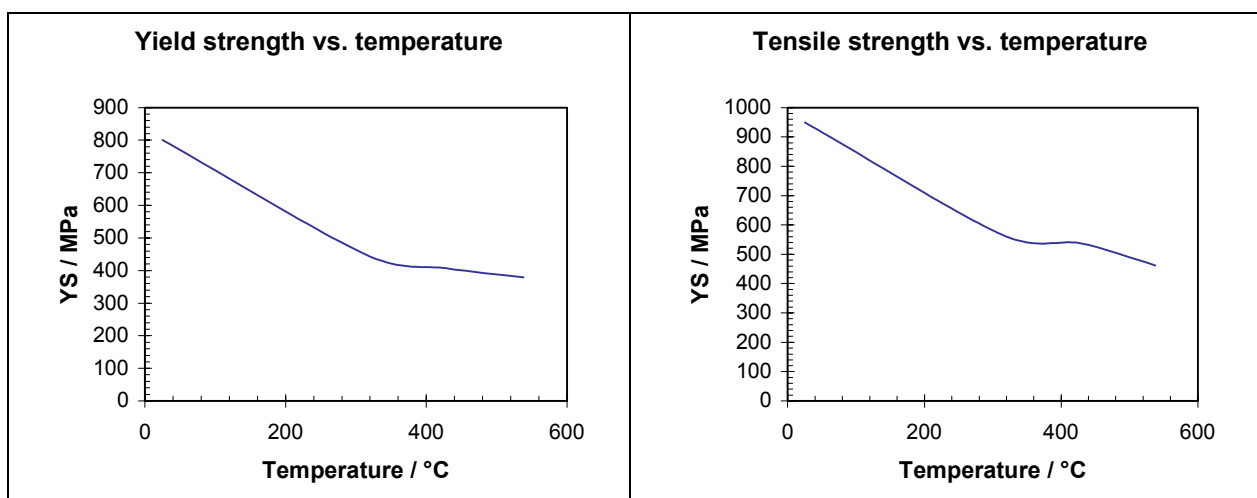

Physical properties	
Melting point, ± 15 °C	1600 °C
Density	4.48 g/cm ³
Beta transus, ± 15 °C	1040 °C
Thermal expansion, 20 - 100 °C	9.4 *10 ⁻⁶ K ⁻¹
Thermal expansion, 0 - 300 °C	9.5 *10 ⁻⁶ K ⁻¹
Thermal conductivity, room temperature	7.8 W/mK
Thermal conductivity, 400 °C	W/mK
Specific heat, room temperature	0.53 J/gK
Specific heat, 400 °C	J/gK
Electrical resistivity, room temperature	160 μW*cm
Poisson's ratio	

Heat treating				
		Temperature	Time	
Annealing	air-cooled	650-760 °C	6 min -	2 hours
Stress relieving	air-cooled	480-595 °C	15 min -	4 hours

Weldability – good

Grade 6 has good weldability

Available mill products

Bar, billett, ingot, plate, sheet, strip, wire, pipe, forging, casting

Typical Applications

Weldable alloy for forgings and sheet metal parts such as aircraft engine compressor blades and ducting, steam turbine blades, rocket engine, ordnance components. Good oxidation resistance and strength at 315-540 °C. Good stability at elevated temperatures. Can be cold-worked and used only in annealed condition

Industry specifications

ASTM Grade6, AMS 4966B, RMI 5Al-2.4Sn, TIMETAL 5-2.5, TITA2

Sheet and plate

AMS 4910, MIL-T-9046 A-1, ASTM B265 Gr6

Bars and billets

ASTM B348 Gr6

Forging

ASTM B381 Gr6, AMS 4966

Bar, forging and circular forgings

AMS 4926

Bar, billett and forging blank

MIL-T-9047

Casting

ASTM B367 Gr6

TITANIUM Grade 7

Commercial pure titanium - 0.15%Pd

The data given is for information not for design

Chemical composition (weight %) (Maximum values unless range is shown)										
O	N	C	H	Fe	Al	V	Ni	Mo	Pd	Residuals
0.25	0.03	0.08	0.015	0.30					0.12-0.25	0.40

Most corrosion-resistant titanium alloy offering outstanding resistance to general and localized crevice corrosion in a wide range of oxidizing and reducing acid environments including chlorides, with a good balance of moderate strength, reasonable ductility and excellent weldability. Physical and mechanical properties equivalent to Grade 2.

Mechanical properties at room temperature		
	Minimum values	Typical values
Yield Strength	275 MPa	350 MPa
Ultimate Strength	345 MPa	485 MPa
Elongation in 50 mm, A5	20 %	28 %
Reduction in Area	30 %	%
Hardness		150 HV
Modulus of elasticity		103 GPa
Charpy V-Notch Impact		40-82 J

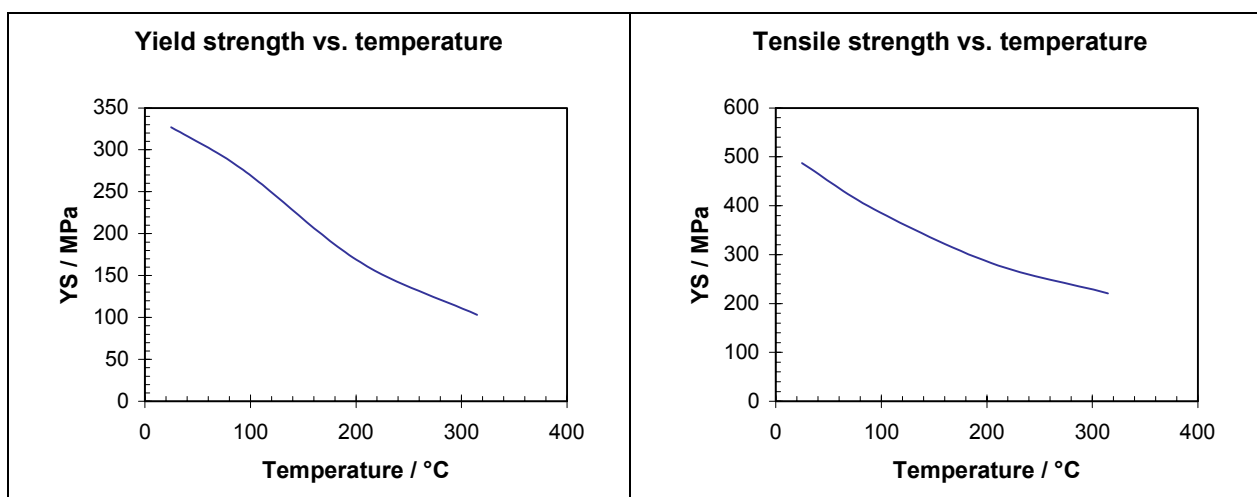

Physical properties	
Melting point, ± 15 °C	1660 °C
Density	4.51 g/cm ³
Beta transus, ± 15 °C	915 °C
Thermal expansion, 20 - 100 °C	8.6 *10 ⁻⁶ K ⁻¹
Thermal expansion, 0 - 300 °C	9.2 *10 ⁻⁶ K ⁻¹
Thermal conductivity, room temperature	20.8 W/mK
Thermal conductivity, 400 °C	16 W/mK
Specific heat, room temperature	0.52 J/gK
Specific heat, 400 °C	0.60 J/gK
Electrical resistivity, room temperature	56 μW*cm
Poisson's ratio	

Heat treating				
		Temperature	Time	
Annealing	air-cooled	650-760 °C	6 min -	2 hours
Stress relieving	air-cooled	480-595 °C	15 min -	4 hours

Weldability – excellent

Grade 7 has very good weldability. Being substantially single phase material, the microstructure of the alpha phase is not affected greatly by thermal treatments or welding temperatures. Therefore, the mechanical properties of a correctly welded joint are equal to, or exceed those of the parent metal and show good ductility.

Available mill products

Bar, billet, ingot, extrusions, plate, sheet, strip, tubing, wire, pipe, forging, casting

Typical Applications

Good corrosion resistance for chemical processing industry applications in which the liquid medium is mildly reducing or varies between oxidizing and reducing. Palladium improves resistance to crevice corrosion. Grade 7 has good formability.

Industry specifications **ASTM Grade7, RMI 0.2 % Pd, TIMETAL 50A Pd, ST-50Pd**

Sheet and plate	ASTM B265 Gr7
Bars and billets	ASTM B348 Gr7
Forging	ASTM B381 Gr7
Casting	ASTM B367 Gr7
Tube	ASTM B337 Gr7, ASTM B338 Gr7

TITANIUM Grade 9

Ti-3Al-2-5V

The data given is for information not for design

Chemical composition (weight %) (Maximum values unless range is shown)										
O	N	C	H	Fe	Al	V	Ni	Mo	Others	Residuals
0.15	0.02	0.08	0.015	0.25	2.5-3.5	2.0-3.0				0.4

This alloy is sometimes referred to as "half 6-4". It offers 20-50% higher strength than C.P. grades, but is more formable and weldable than Ti-6Al-4V. Grade 9 combines strength, weldability and formability. The alloy has excellent formability plus higher tensile strength than the strongest unalloyed grade.

Mechanical properties at room temperature		
	Minimum values	Typical values
Yield Strength	485 MPa	610 MPa
Ultimate Strength	620 MPa	740 MPa
Elongation in 50 mm, A5	15 %	17 %
Reduction in Area	25 %	%
Hardness		260-320 HV
Modulus of elasticity		107 GPa
Charpy V-Notch Impact		48-102 J

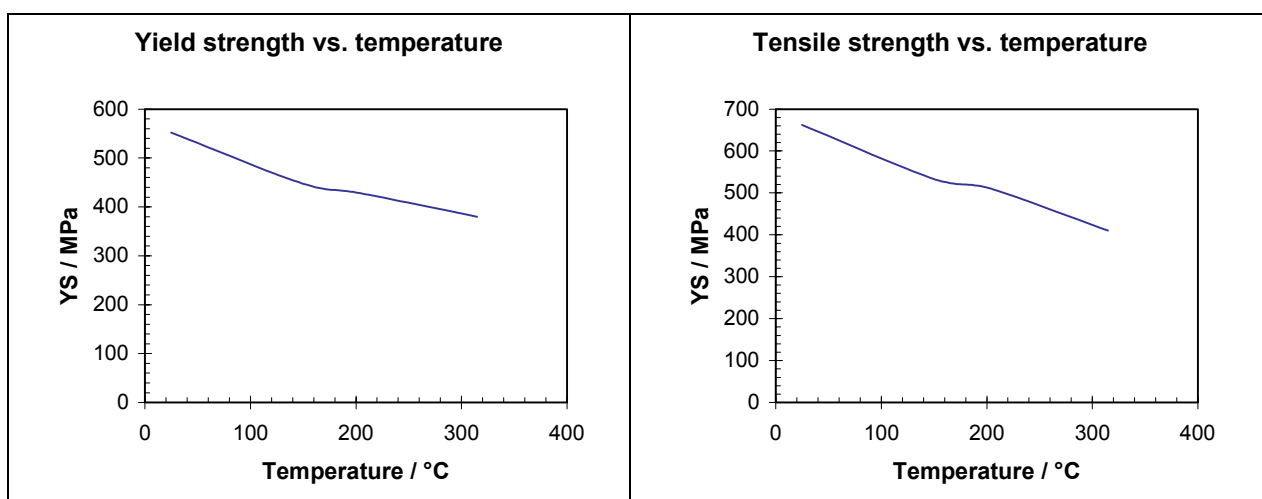

Fatigue properties at room temperature (Stress to cause failure in 10^7 Cycles)	
Rotating bend	
Smooth $K_t=1$	373 MPa
Notch $K_t=3$	MPa

Physical properties	
Melting point, ± 15 °C	1700 °C
Density	4.48 g/cm ³
Beta transus, ± 15 °C	935 °C
Thermal expansion, 20 - 100 °C	9.5 *10 ⁻⁶ K ⁻¹
Thermal expansion, 0 - 300 °C	9.9 *10 ⁻⁶ K ⁻¹
Thermal conductivity, room temperature	8.3 W/mK
Thermal conductivity, 400 °C	W/mK
Specific heat, room temperature	0.54 J/gK
Specific heat, 400 °C	J/gK
Electrical resistivity, room temperature	126 μW*cm
Poisson's ratio	0.34

Heat treating			
		Temperature	Time
Annealing	air-cooled	595-760 °C	1 - 3 hours
Stress relieving	air-cooled	315-650 °C	1 - 3 hours

Weldability – good

Grade 9 has good weldability. Since the two-phase microstructure of alpha-beta titanium alloys respond to thermal treatment, the temperatures encountered during the welding cycle can affect the material being welded. A properly chosen filler rod can improve the toughness and ductility of alpha-beta welds.

Available mill products

Billet, ingot, plate, sheet, strip, tubing (welded), wire, pipe

Typical Applications

Grade 9 is used in aircraft hydraulic tubing and fittings, foil. It is principally used as tubing in aircraft and engine hydraulic systems, for high strength corrosion resisting applications such as pipes and vessels and as foil for honeycomb applications.

Industry specifications ASTM Grade9, TIMETAL 3 - 2.5

Sheet and plate	ASTM B265 Gr9, MIL-T-9046 AB-5
Bars and billets	ASTM B348 Gr9
Bar, billet and forging blank	MIL-T-9047
Forging	ASTM B381 Gr9
Tube	ASTM B337 Gr9, ASTM B338 Gr9, AMS 4943, AMS 4944

TITANIUM Grade 12

Ti - 0.3Mo - 0.8Ni

The data given is for information not for design

Chemical composition (weight %) (Maximum values unless range is shown)										
O	N	C	H	Fe	Al	V	Ni	Mo	Others	Residuals
0.25	0.03	0.08	0.015	0.30			0.6-0.9	0.2-0.4		0.4

Highly weldable, near-alpha titanium alloy exhibiting improved strength and optimum ASME Code design allowable at increased temperatures, combined with superior crevice corrosion resistance, and excellent resistance under oxidizing to mildly reducing conditions, especially chlorides.

Mechanical properties at room temperature		
	Minimum values	Typical values
Yield Strength	345 MPa	465 MPa
Ultimate Strength	485 MPa	610 MPa
Elongation in 50 mm, A5	18 %	22 %
Reduction in Area	25 %	%
Hardness		170-240 HV
Modulus of elasticity		103 GPa
Charpy V-Notch Impact		16-27 J

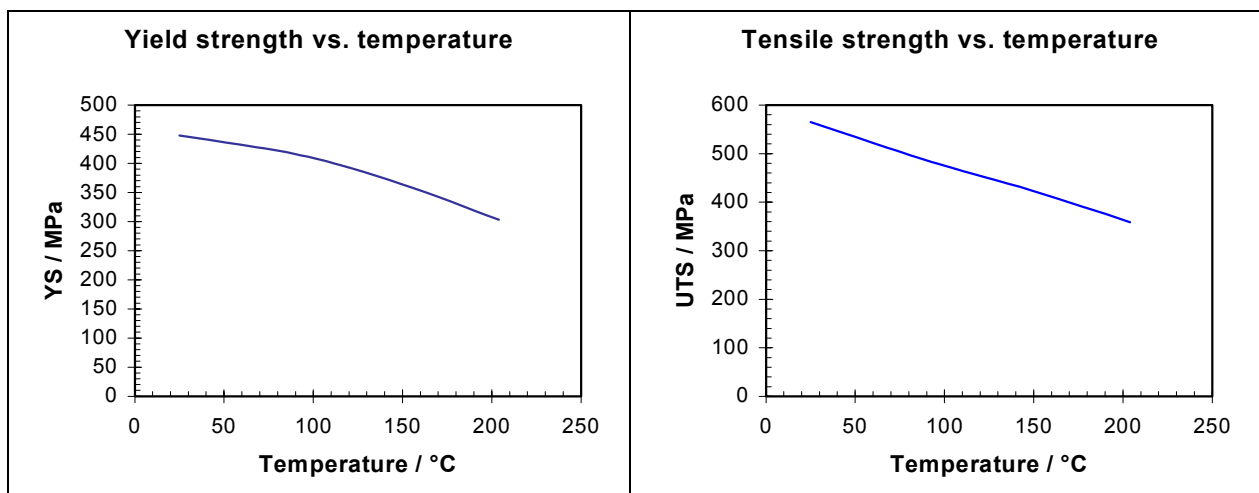

Physical properties	
Melting point, ± 15 °C	1660 °C
Density	4.51 g/cm ³
Beta transus, ± 15 °C	890 °C
Thermal expansion, 20 - 100 °C	9.5 *10 ⁻⁶ K ⁻¹
Thermal expansion, 0 - 300 °C	9.6 *10 ⁻⁶ K ⁻¹
Thermal conductivity, room temperature	19 W/mK
Thermal conductivity, 400 °C	W/mK
Specific heat, room temperature	0.54 J/gK
Specific heat, 400 °C	J/gK
Electrical resistivity, room temperature	52 μW*cm
Poisson's ratio	

Heat treating		
		Temperature
Annealing	air-cooled	730-815 °C
Stress relieving	air-cooled	540-650 °C

Weldability – excellent

Grade 12 has very good weldability. Being substantially single-phase material, the microstructure of the alpha phase is not affected greatly by thermal treatments or welding temperatures. Therefore, the mechanical properties of a correctly welded joint are equal to, or exceed those of the parent metal and show good ductility.

Available mill products

Billet, ingot, plate, sheet, strip, tubing (welded), wire, pipe, forging

Typical Applications

Grade 12 is developed specifically for the process industries and is similar to the Ti-Pd alloys. Grade 12 has improved resistance to crevice corrosion in hot brines, and extends titanium's usefulness in harsh environments.

Industry specifications

ASTM Grade12, TIMETAL Code12

Sheet and plate	ASTM B265 Gr12
Bars and billets	ASTM B348 Gr12
Forging	ASTM B381 Gr12
Tube	ASTM B337 Gr12, ASTM B338 Gr12

TITANIUM Grade 16

Commercial pure titanium - 0.05%Pd (Grade 2 with Pd)

The data given is for information not for design

Chemical composition (weight %) (Maximum values unless range is shown)										
O	N	C	H	Fe	Al	V	Ni	Mo	Pd	Residuals
0.25	0.03	0.08	0.015	0.30					0.04-0.08	0.40

Corrosion-resistant titanium alloy offering outstanding resistance to general and localized crevice corrosion in a wide range of oxidizing and reducing acid environments including chlorides. Has a good balance of moderate strength, reasonable ductility and excellent weldability.

Mechanical properties at room temperature		
	Minimum values	Typical values
Yield Strength	275 MPa	350 MPa
Ultimate Strength	345 MPa	485 MPa
Elongation in 50 mm, A5	20 %	28 %
Reduction in Area	%	%
Hardness		150 HV
Modulus of elasticity		103 GPa
Charpy V-Notch Impact		40-82 J

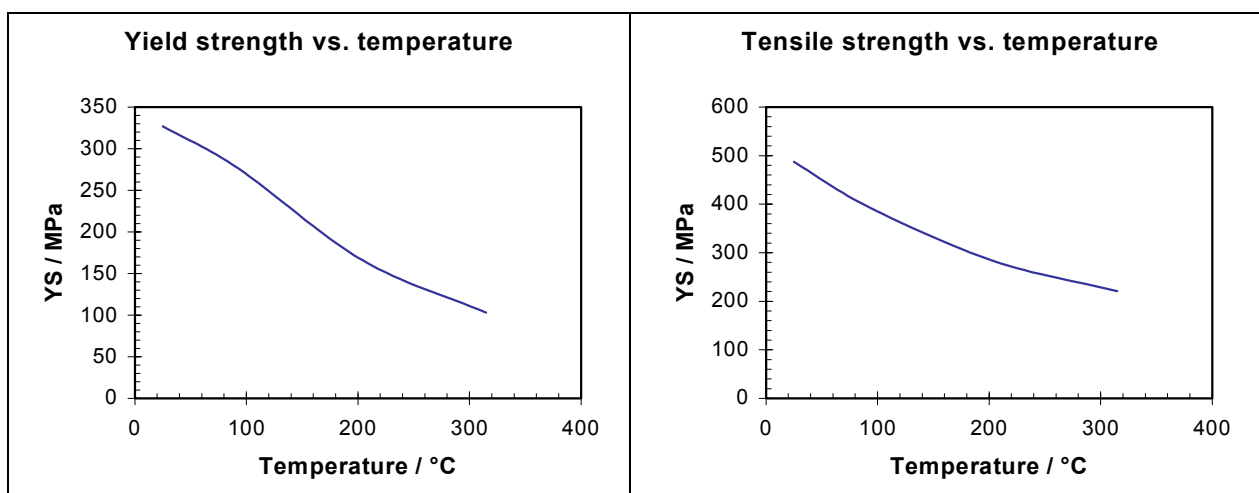

Physical properties	
Melting point, ± 15 °C	1660 °C
Density	4.51 g/cm ³
Beta transus, ± 15 °C	915 °C
Thermal expansion, 20 - 100 °C	8.6 *10 ⁻⁶ K ⁻¹
Thermal expansion, 0 - 300 °C	9.2 *10 ⁻⁶ K ⁻¹
Thermal conductivity, room temperature	20.8 W/mK
Thermal conductivity, 400 °C	16 W/mK
Specific heat, room temperature	0.52 J/gK
Specific heat, 400 °C	0.60 J/gK
Electrical resistivity, room temperature	56 μW*cm
Poisson's ratio	0.34-0.40

Heat treating			
		Temperature	Time
Annealing	air-cooled	650-760 °C	6 min - 2 hours
Stress relieving	air-cooled	480-595 °C	15 min - 4 hours

Weldability – excellent

Grade 16 has very good weldability. Being substantially single phase material, the microstructure of the alpha phase is not affected greatly by thermal treatments or welding temperatures. Therefore, the mechanical properties of a correctly welded joint are equal to, or exceed those of the parent metal and show good ductility.

Available mill products

Bar, billet, ingot, extrusions, plate, sheet, strip, tubing, wire, pipe, forging, casting

Typical Applications

Good corrosion resistance for chemical processing industry applications in which the liquid medium is mildly reducing or varies between oxidizing and reducing.

Palladium improves resistance to crevice corrosion. Grade 16 has good formability.

Industry specifications ASTM Grade16

Sheet and plate	ASTM B265
Bars and billets	ASTM B348
Forging	ASTM B381
Casting	ASTM B367
Tube	ASTM B337, ASTM B338

TITANIUM Grade 17

Commercial pure titanium with 0.05%Pd (Grade 1 with Pd)

The data given is for information not for design

Chemical composition (weight %) (Maximum values unless range is shown)										
O	N	C	H	Fe	Al	V	Ni	Mo	Pd	Residuals
0.18	0.03	0.08	0.015	0.2					0.04-0.08	0.4

This alloy is the same as Grade 1, but with Pd for better corrosion resistance. Grade 17 has optimum ductility and cold formability with useful strength, high-impact toughness, and excellent weldability. Very resistant to crevice corrosion.

Mechanical properties at room temperature		
	Minimum values	Typical values
Yield Strength	170 MPa	220 MPa
Ultimate Strength	240 MPa	345 MPa
Elongation in 50 mm, A5	25 %	37 %
Reduction in Area	35 %	%
Hardness		115 HV
Modulus of elasticity		103 GPa
Charpy V-Notch Impact		95-162 J

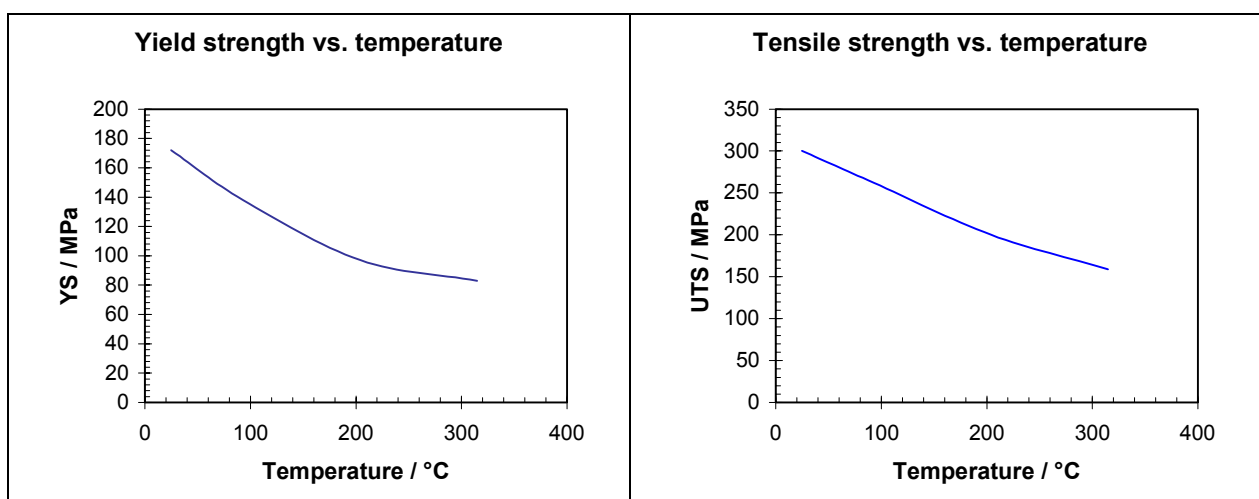

Fatigue properties at room temperature (Stress to cause failure in 10^7 Cycles)		
Rotating bend		
Smooth	$K_t=1$	193 MPa
Notch	$K_t=3$	123 MPa

Physical properties	
Melting point, ± 15 °C	1670 °C
Density	4.51 g/cm ³
Beta transus, ± 15 °C	890 °C
Thermal expansion, 20 - 100 °C	8.6 *10 ⁻⁶ K ⁻¹
Thermal expansion, 0 - 300 °C	9.2 *10 ⁻⁶ K ⁻¹
Thermal conductivity, room temperature	20.8 W/mK
Thermal conductivity, 400 °C	W/mK
Specific heat, room temperature	0.52 J/gK
Specific heat, 400 °C	0.60 J/gK
Electrical resistivity, room temperature	54 μW*cm
Poisson's ratio	0.34-0.40

Heat treating			
		Temperature	Time
Annealing	air-cooled	650-760 °C	6 min - 2 hours
Stress relieving	air-cooled	480-595 °C	15 min - 4 hours

Weldability – excellent

Grade 17 has very good weldability. Being substantially single-phase material, the microstructure of the alpha phase is not affected greatly by thermal treatments or welding temperatures. Therefore, the mechanical properties of a correctly welded joint are equal to, or exceed those of the parent metal and show good ductility

Available mill products

Bar, billet, ingot, extrusions, plate, sheet, strip, tubing, wire, pipe, forging

Typical Applications

Very good corrosion resistance for chemical processing industry applications in which the liquid medium is mildly reducing or varies between oxidizing and reducing. Palladium improves resistance to crevice corrosion. Grade 11 has good formability.

Industry specifications ASTM Grade17

Sheet and plate	ASTM B265
Bars and billets	ASTM B348
Tube	ASTM B337, ASTM B338
Forging	ASTM B381

TITANIUM Grade 19

Beta-C

The data given is for information not for design

Chemical composition (weight %) (Maximum values unless range is shown)										
O	N	C	H	Fe	Al	V	Cr	Mo	Zr	Residuals
0.12	0.03	0.05	0.015	0.3	3.0-4.0	7.5-8.5	5.5-6.5	3.5-4.5	3.5-4.5	0.4

This metastable-beta alloy is strip-producible and cold-formable. The alloy is age-hardenable to a wide range of strengths. Beta-C is also being evaluated as extruded tubular for deep sour well applications. The alloy is superior resistant to general Corrosion pitting-, crevice- and stress Corrosion cracking in high temperature environments containing FeCl₃, NaCl, CO₂ and H₂S.

Mechanical properties at room temperature		
	Minimum values	Typical values
Yield Strength	1105 MPa	1150 MPa
Ultimate Strength	1170 MPa	1250 MPa
Elongation in 50 mm, A5	6 %	9 %
Reduction in Area	%	30 %
Hardness		360-420 HV
Modulus of elasticity		102 GPa
Charpy V-Notch Impact		11-16 J

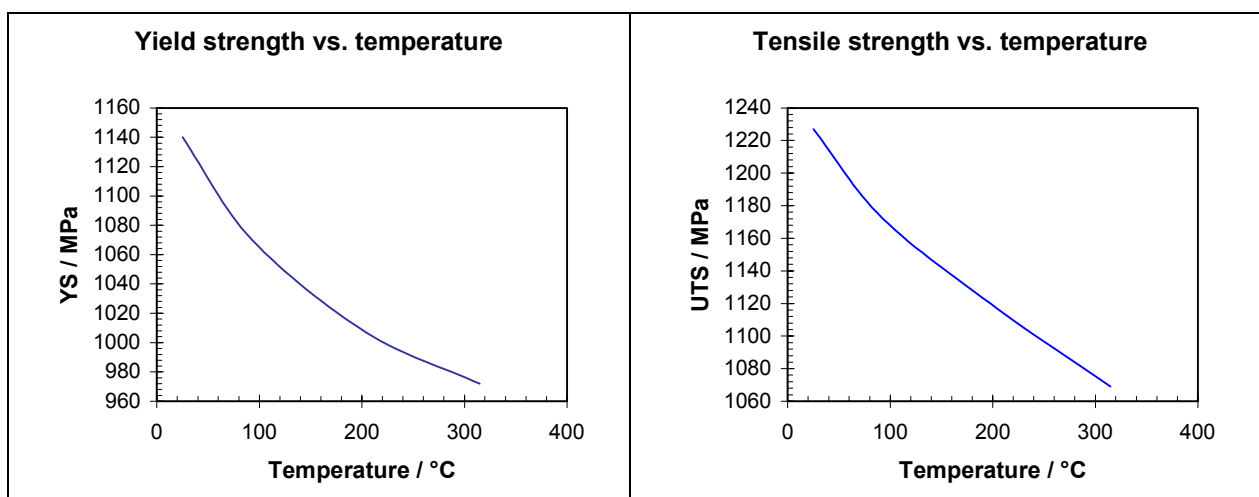

Fatigue properties at room temperature (Stress to cause failure in 10 ⁷ Cycles)			
Direct stress fatigue limit			
Smooth	K _t =1	600	MPa
Notch	K _t =3	275	MPa

Physical properties	
Melting point, ± 15 °C	1650 °C
Density	4.82 g/cm ³
Beta transus, ± 15 °C	730 °C
Thermal expansion, 20 - 100 °C	8.3 *10 ⁻⁶ K ⁻¹
Thermal expansion, 0 - 300 °C	9.5 *10 ⁻⁶ K ⁻¹
Thermal conductivity, room temperature	6.2 W/mK
Thermal conductivity, 400 °C	W/mK
Specific heat, room temperature	0.52 J/gK
Specific heat, 400 °C	J/gK
Electrical resistivity, room temperature	160 μW*cm
Poisson's ratio	0.34

Heat treating				
		Temperature	Time	
Annealing	air-cooled/water	705-760°C	6min -	30min
Stress relieving	air-cooled	705-760°C	6min -	30min
Solution treating	water quench	815-925°C	1 hour	
Aging	air-cooled	455-540°C	8hours -	24hours

Weldability – fair

Beta - C is weldable in annealed or solution treated Condition. The weld has often low strength and good ductility. To gain fully strength in metastable alloys it is important to weld the alloy in annealed Condition. The welds have to be cold worked (sandblasting, hammering) after welding. At the end the welds goes through solution treatment and aging. This treatment usually gives the weld a satisfactory ductility.

Available mill products

Billet, billett, plate, sheet, ingot, wire, pipe, forging

Typical Applications

Heavy sections where deep hardening and high strength with good fracture toughness are required. The alloy has been used for springs, fasteners, torsion bars, sheet, rivets and foil applications. Tubing and casing down hole production equipment.

Industry specifications

Sheet and plate	MIL-T-909046 B-3
Bar, billett and forging blank	MIL-T-9047
	ASM 4957
	ASM 4958

TITANIUM Grade 21

Beta - 21S

The data given is for information not for design

Chemical composition (weight %) (Maximum values unless range is shown)										
O	N	C	H	Fe	Mo	Nb	Al	Si	Others	Residuals
0.15	0.05	0.05	0.015	0.4	14.0-16.0	2.2-3.2	2.3	3.5		0.4

Beta - 21S is a metastable beta alloy that offers high specific strength and good formability, and has been designed for improved oxidation resistance, elevated temperature strength, creep resistance and thermal stability. It is most useful for application above 300 °C. Because it can be economically rolled to foil and is compatible with most fibres, it is also well suited for metal matrix composites.

Mechanical properties at room temperature*		
	Minimum values	Typical values
Yield Strength	965 MPa	1100 MPa
Ultimate Strength	1030 MPa	1150 MPa
Elongation in 50 mm, A5	6 %	10 %
Reduction in Area	%	%
Hardness		360-420 HV
Modulus of elasticity		72-85 GPa
Charpy V-Notch Impact		103-110 J

* Aged at 600 °C

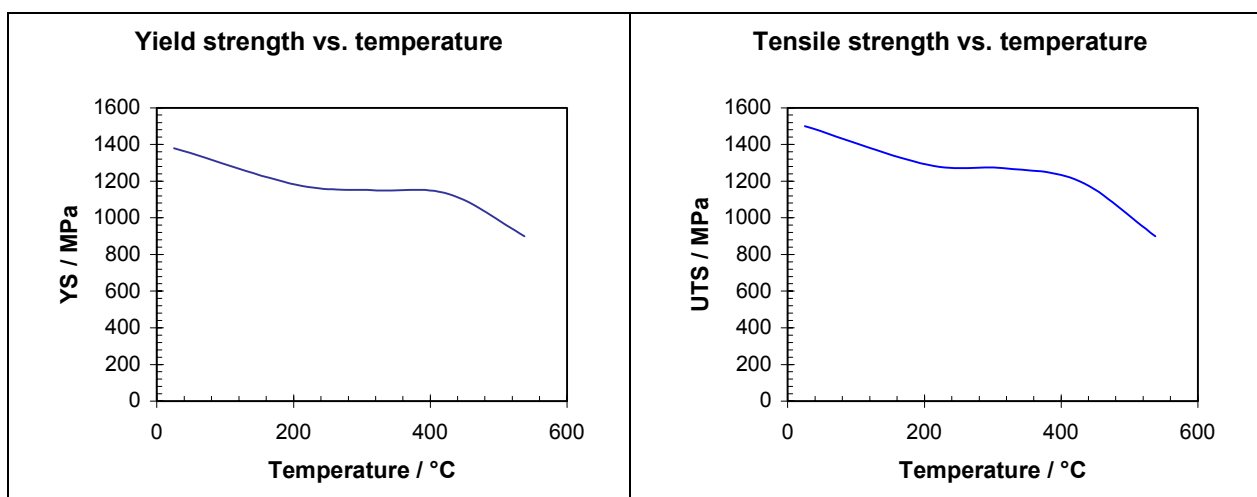

Physical properties	
Melting point, ± 15 °C	°C
Density	4.9 g/cm ³
Beta transus, ± 15 °C	815 °C
Thermal expansion, 30 °C	7.1 *10 ⁻⁶ K ⁻¹
Thermal expansion, 200 °C	7.9 *10 ⁻⁶ K ⁻¹
Thermal conductivity, room temperature	7.6 W/mK
Thermal conductivity, 400 °C	16.9 W/mK
Specific heat, room temperature	0.5 J/gK
Specific heat, 400 °C	0.6 J/gK
Electrical resistivity, room temperature	135 μW*cm
Poisson's ratio	0.34

Heat treating			
		Temperature	Time
Annealing	air-cooled	815-845 °C	3-30 min
Stress relieving	air-cooled	510-650 °C	8-16 hours

Weldability – fair

Available mill products

Forging, tube

Typical Applications

Warm airframes of engine structures, honeycomb, fasteners, metal matrix composites. TIMETAL 21S is useful for applications from 230°C to 600°C. The alloy is resistant to aircraft hydraulic fluids. It is well suited for metal matrix composites because it can be economically rolled to foil, is compatible with most fibers, and is sufficiently stable up to 820°C.

Industry specifications

TIMETAL 21S

TITANIUM Grade 23

Ti - 6Al - 4V ELI (Extra low interstitials)

The data given is for information not for design

Chemical composition (weight %) (Maximum values unless range is shown)										
O	N	C	H	Fe	Al	V	Ni	Mo	Others	Residuals
0.13	0.03	0.08	0.0125	0.25	5.5-6.5	3.5-4.5				0.4

An alpha-beta alloy based on Grade 5. The amount of interstitial elements (O, N, C) is reduced. Improved stress corrosion cracking (SCC) properties in seawater compared to Grade 5. Especially suited for thick wall highly stressed parts.

Mechanical properties at room temperature

	Minimum values	Typical values
Yield Strength	790(760) MPa	825 MPa
Ultimate Strength	860(825) MPa	895 MPa
Elongation in 50 mm, A5	10 (7.5) %	15 %
Reduction in Area	25 (15) %	%
Hardness		350 HV
Modulus of elasticity		114 GPa
Charpy V-Notch Impact		24-40 J

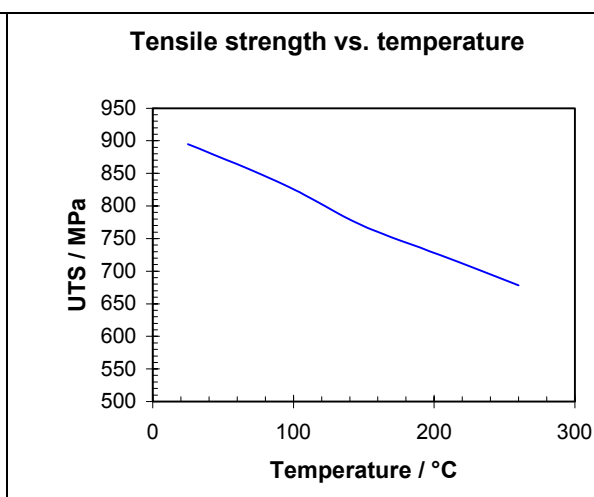
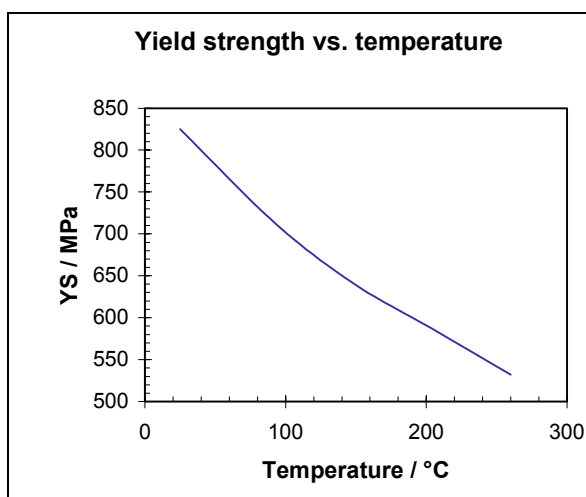

Fatigue properties at room temperature

300 MPa unnotched

140 MPa notched with stress concentration factor $K_t=3.1$

Physical properties	
Melting point, ± 15 °C	1650 °C
Density	4.43 g/cm ³
Beta transus, ± 15 °C	980 °C
Thermal expansion, 20 - 100 °C	9.2 *10 ⁻⁶ K ⁻¹
Thermal expansion, 0 - 300 °C	9.5 *10 ⁻⁶ K ⁻¹
Thermal conductivity, room temperature	7.3 W/mK
Thermal conductivity, 400 °C	W/mK
Specific heat, room temperature	0.57 J/gK
Specific heat, 400 °C	J/gK
Electrical resistivity, room temperature	165 μW*cm
Poisson's ratio	0.34

Heat treating				
		Temperature	Time	
Solution treating temperature	water quench	900-950°C	1 hour	
Ageing temperature		480-590°C	4hours	8hours
Full annealing	air-cooled	700-830°C	15 min -	2 hours
Stress relieving	air-cooled	480-650°C	60min -	4hours

Weldability – good

The same welding procedure as for Grade 5 can be used, but special filler metal required

Available mill products

Bar, billett, extrusions, plate, sheet, strip, wire

Typical Applications

Surgical implants, offshore- and seawater applications, high pressure cryogenic vessels down to -195 °C. Improved stress corrosion resistance compared to Grade 5.

Industry specifications

ASTM - B265, B348, B363, B381, B861, B862 and F136
AMS - 4907, 4930 and 4956

TITANIUM Grade 26

Commercial pure titanium - 0.1%Ru (Grade 2 with Ru)

The data given is for information not for design

Chemical composition (weight %) (Maximum values unless range is shown)										
O	N	C	H	Fe	Al	V	Ni	Mo	Ru	Residuals
0.25	0.03	0.08	0.015	0.30					0.08-0.14	0.40

Corrosion-resistant titanium alloy offering outstanding resistance to general and localized crevice corrosion in a wide range of oxidizing and reducing acid environments including chlorides, with a good balance of moderate strength, reasonable ductility and excellent weldability. Mechanical properties similar to Grade 2, but improved corrosion resistance.

Mechanical properties at room temperature		
	Minimum values	Typical values
Yield Strength	275 MPa	350 MPa
Ultimate Strength	345 MPa	485 MPa
Elongation in 50 mm, A5	20 %	28 %
Reduction in Area	30 %	%
Hardness		150 HV
Modulus of elasticity		103 GPa
Charpy V-Notch Impact		40-82 J

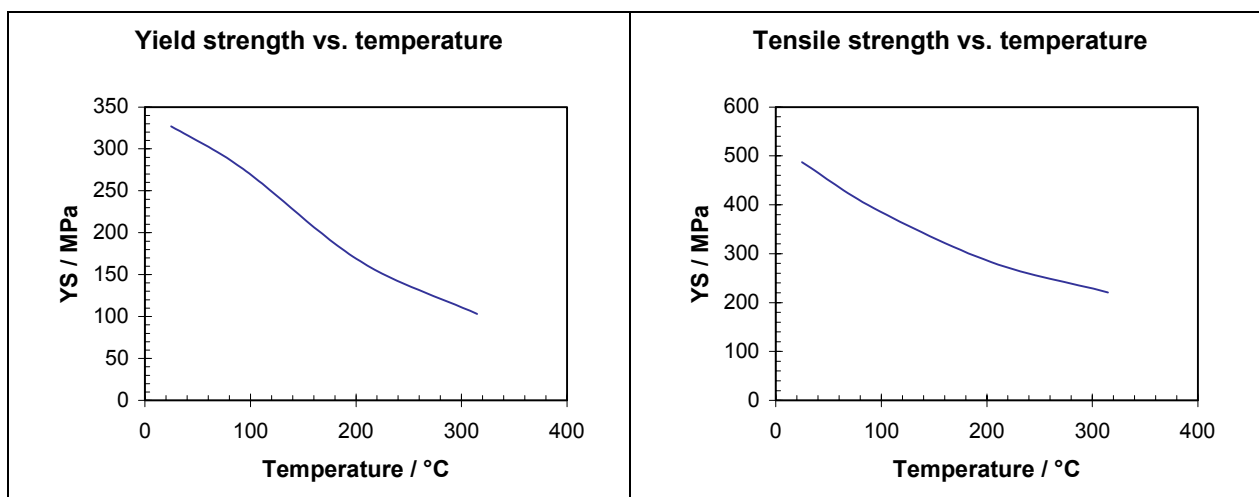

Physical properties	
Melting point, ± 15 °C	1660 °C
Density	4.51 g/cm ³
Beta transus, ± 15 °C	915 °C
Thermal expansion, 20 - 100 °C	8.6 *10 ⁻⁶ K ⁻¹
Thermal expansion, 0 - 300 °C	9.2 *10 ⁻⁶ K ⁻¹
Thermal conductivity, room temperature	20.8 W/mK
Thermal conductivity, 400 °C	16 W/mK
Specific heat, room temperature	0.52 J/gK
Specific heat, 400 °C	0.6 J/gK
Electrical resistivity, room temperature	56 μW*cm
Poisson's ratio	

Heat treating			
		Temperature	Time
Annealing	air-cooled	650-760 °C	6 min - 2 hours
Stress relieving	air-cooled	480-595 °C	15 min - 4 hours

Weldability – excellent

Grade 26 has very good weldability. Being substantially single phase material, the microstructure of the alpha phase is not affected greatly by thermal treatments or welding temperatures. Therefore, the mechanical properties of a correctly welded joint are equal to, or exceed those of the parent metal and show good ductility.

Available mill products

Bar, billet, ingot, extrusions, plate, sheet, strip, tubing, wire, pipe, forging, casting

Typical Applications

Good corrosion resistance for chemical processing industry applications in which the liquid medium is mildly reducing or varies between oxidizing and reducing.

Palladium improves resistance to crevice corrosion. Grade 26 has good formability.

Industry specifications ASTM Grade26

Sheet and plate	ASTM B265
Bars and billets	ASTM B348
Forging	ASTM B381
Casting	ASTM B367
Tube	ASTM B337 , ASTM B338

TITANIUM Grade 27

Commercial pure titanium with 0.1%Ru (Grade 1 with Ru)

The data given is for information not for design

Chemical composition (weight %) (Maximum values unless range is shown)										
O	N	C	H	Fe	Al	V	Ni	Mo	Ru	Residuals
0.18	0.03	0.08	0.015	0.2					0.08-0.14	0.4

This alloy is the same as Grade 1, but with Ruthenium for better corrosion resistance. Grade 27 has optimum ductility and cold formability with useful strength, high-impact toughness, and excellent weldability. Very resistant to crevice corrosion.

Mechanical properties at room temperature		
	Minimum values	Typical values
Yield Strength	170 MPa	220 MPa
Ultimate Strength	240 MPa	345 MPa
Elongation in 50 mm, A5	25 %	37 %
Reduction in Area	30 %	%
Hardness		115 HV
Modulus of elasticity		103 GPa
Charpy V-Notch Impact		95-162 J

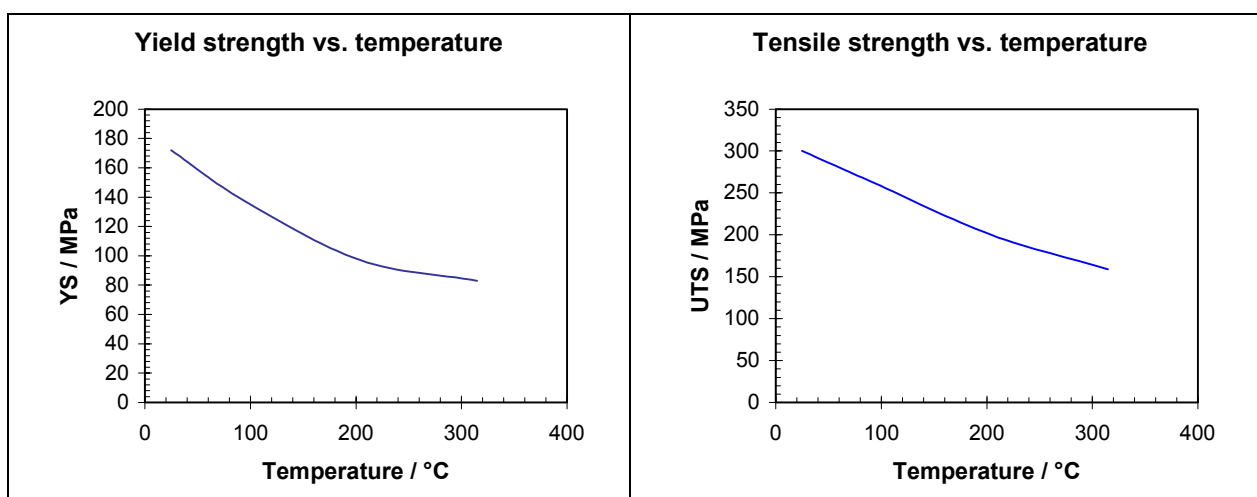

Fatigue properties at room temperature (Stress to cause failure in 10^7 Cycles)		
Rotating bend		
Smooth	$K_t=1$	193 MPa
Notch	$K_t=3$	123 MPa

Physical properties	
Melting point, ± 15 °C	1670 °C
Density	4.51 g/cm ³
Beta transus, ± 15 °C	890 °C
Thermal expansion, 20 - 100 °C	$8.6 \cdot 10^{-6} \text{ K}^{-1}$
Thermal expansion, 0 - 300 °C	$9.2 \cdot 10^{-6} \text{ K}^{-1}$
Thermal conductivity, room temperature	20.8 W/mK
Thermal conductivity, 400 °C	W/mK
Specific heat, room temperature	0.52 J/gK
Specific heat, 400 °C	0.60 J/gK
Electrical resistivity, room temperature	56 $\mu\text{W}\cdot\text{cm}$
Poisson's ratio	0.34-0.40

Heat treating			
		Temperature	Time
Annealing	air-cooled	650-760 °C	6 min - 2 hours
Stress relieving	air-cooled	480-595 °C	15 min - 4 hours

Weldability – excellent

Grade 27 has very good weldability. Being substantially single-phase material, the microstructure of the alpha phase is not affected greatly by thermal treatments or welding temperatures. Therefore, the mechanical properties of a correctly welded joint are equal to, or exceed those of the parent metal and show good ductility.

Available mill products

Bar, billet, ingot, extrusions, plate, sheet, strip, tubing, wire, pipe, forging

Typical Applications

Very good corrosion resistance for chemical processing industry applications in which the liquid medium is mildly reducing or varies between oxidizing and reducing. Palladium improves resistance to crevice corrosion. Grade 11 has good formability.

Industry specifications	ASTM Grade27
Sheet and plate	ASTM B265
Bars and billets	ASTM B348
Tube	ASTM B337, ASTM B338
Forging	ASTM B381

TITANIUM Grade 28

Ti - 3Al - 2.5V - 0.1 Ru (Grade 9 with Ru)

The data given is for information not for design

Chemical composition (weight %) (Maximum values unless range is shown)										
O	N	C	H	Fe	Al	V	Ni	Mo	Ru	Residuals
0.15	0.03	0.08	0.015	0.25	2.5-3.5	2.0-3.0			0.08-0.14	0.4

Grade 9 with Ruthenium for improved corrosion resistance.

Mechanical properties at room temperature		
	Minimum values	Typical values
Yield Strength	485 MPa	610 MPa
Ultimate Strength	620 MPa	740 MPa
Elongation in 50 mm, A5	15 %	17 %
Reduction in Area	25 %	%
Hardness		260-320 HV
Modulus of elasticity		107 GPa
Charpy V-Notch Impact		48-102 J

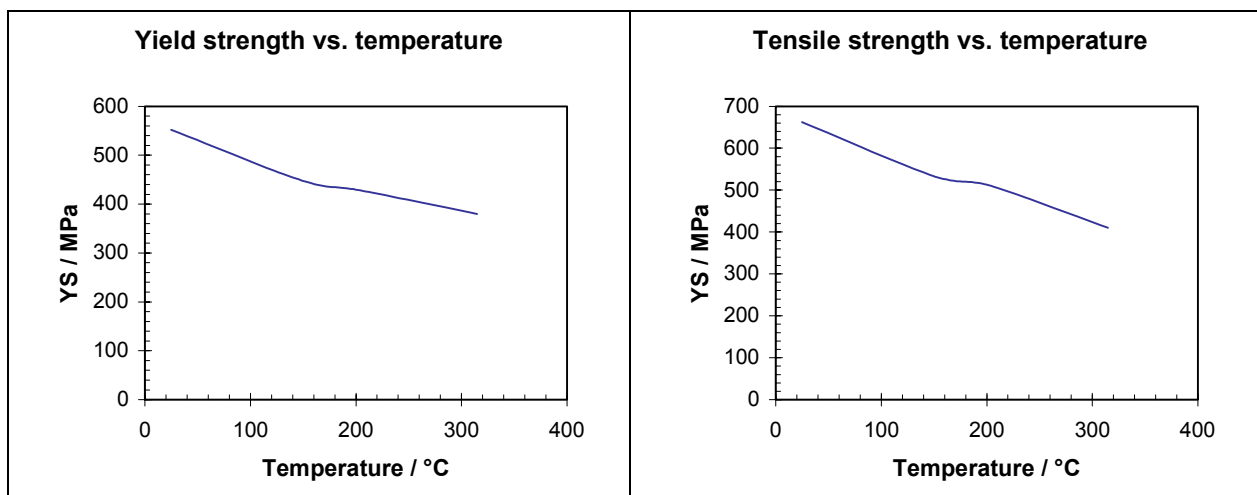

Fatigue properties at room temperature (Stress to cause failure in 10^7 Cycles)	
Rotating bend	
Smooth $K_t=1$	373 MPa

Physical properties	
Melting point, ± 15 °C	1700 °C
Density	4.48 g/cm ³
Beta transus, ± 15 °C	935 °C
Thermal expansion, 20 - 100 °C	9.5 *10 ⁻⁶ K ⁻¹
Thermal expansion, 0 - 300 °C	9.9 *10 ⁻⁶ K ⁻¹
Thermal conductivity, room temperature	7.9 W/mK
Thermal conductivity, 400 °C	7.6 W/mK
Specific heat, room temperature	0.55 J/gK
Specific heat, 400 °C	J/gK
Electrical resistivity, room temperature	126 μW*cm
Poisson's ratio	0.34

Heat treating			
		Temperature	Time
Annealing	air-cooled	595-760°C	1 - 3 hours
Stress relieving	air-cooled	315-650°C	0.5 - 3 hours
Solution treating	water quench	870-925°C	15 -20hours
Aging	air-cooled	480-510°C	2 - 8hours

Weldability – good

Same procedure as Grade 9, but special filler material is recommended.

Available mill products

Billet, ingot, plate, sheet, strip, tubing (welded), wire, pipe

Typical Applications

Seawater applications.

High crevice corrosion temperature.

Industry specifications ASTM Grade 28

ASTM B265, B337, B338, B381, B861, B862

TITANIUM Grade 29

Ti - 6Al - 4V - 0.1Ru ELI (Extra low interstitials)

The data given is for information not for design

Chemical composition (weight %) (Maximum values unless range is shown)										
O	N	C	H	Fe	Al	V	Ni	Mo	Ru	Residuals
0.13	0.03	0.08	0.0125	0.25	5.5-6.5	3.5-4.5			0.08-0.14	0.4

Grade 23 with Ruthenium for improved corrosion resistance. High crevice corrosion temperature, improved stress corrosion resistance compared to Grade 5.

Mechanical properties at room temperature		
	Minimum values	Typical values
Yield Strength	790(760) MPa	825 MPa
Ultimate Strength	860(825) MPa	895 MPa
Elongation in 50 mm, A5	10 (7.5) %	15 %
Reduction in Area	25 (15) %	%
Hardness		350 HV
Modulus of elasticity		114 GPa
Charpy V-Notch Impact		24-40 J

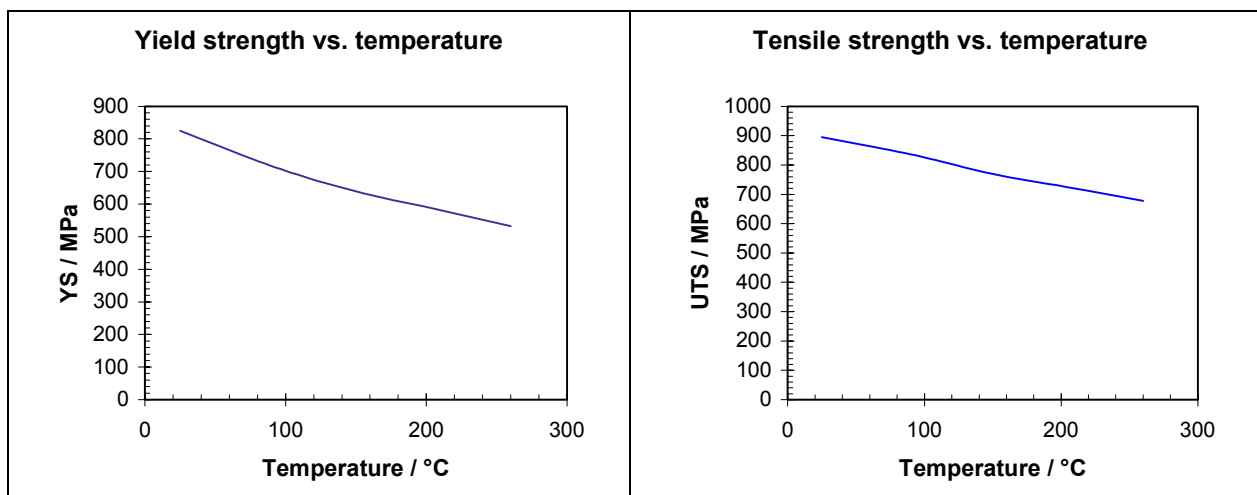

Fatigue properties at room temperature (Stress to cause failure in 10^7 Cycles)

300 MPa unnotched

140 MPa notched with stress concentration factor $K_t=3.1$

Physical properties	
Melting point, ± 15 °C	1650 °C
Density	4.43 g/cm ³
Beta transus, ± 15 °C	990 °C
Thermal expansion, 20 - 100 °C	9.2 *10 ⁻⁶ K ⁻¹
Thermal expansion, 0 - 300 °C	9.5 *10 ⁻⁶ K ⁻¹
Thermal conductivity, room temperature	7.3 W/mK
Thermal conductivity, 400 °C	W/mK
Specific heat, room temperature	0.57 J/gK
Specific heat, 400 °C	J/gK
Electrical resistivity, room temperature	165 μW*cm
Poisson's ratio	0.34

Heat treating			
		Temperature	Time
Solution treating temperature	water quench	900-950 °C	1 hour
Ageing temperature		480-590 °C	4hours 8hours
Full annealing	air-cooled	700-830 °C	15min - 2hours
Stress relieving	air-cooled	480-650 °C	60min - 4hours

Weldability – good

The same welding procedure as for Grade 5 can be used, but special filler metal required

Available mill products

Bar, billett, extrusions, plate, sheet, strip, wire

Typical Applications

Seawater and offshore applications

High crevice corrosion temperature, improved stress corrosion resistance compared to Grade 5.

Industry specifications

ASTM - B265, B348, B363, B381, B861, B862 and F136

AMS - 4907, 4930 and 4956

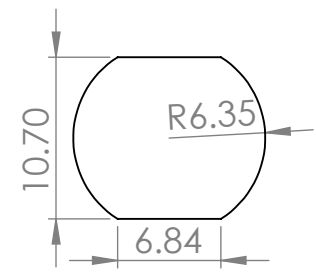
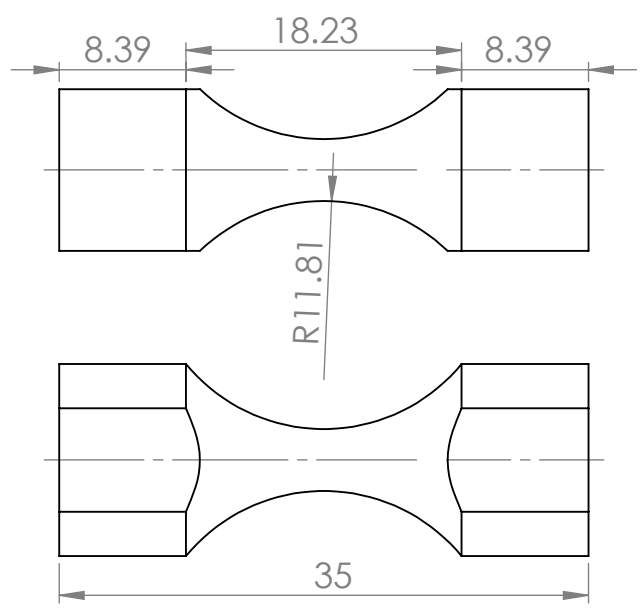
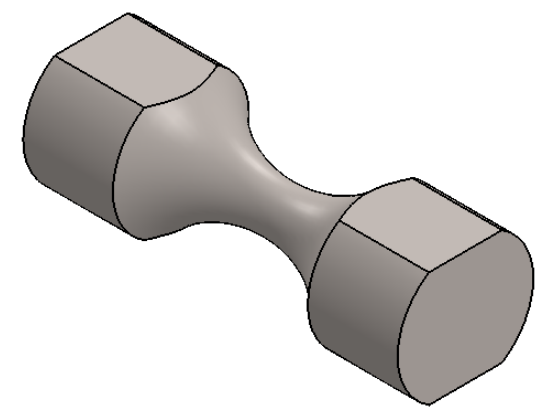

Units mm

		Units mm			
	NAME			TITLE: Torsional property of Nano-Structured Titanium for use in Biomedical Application	
SMS	Saleh AL Shammari				
AAZ	Ahmed AL Zahrani				
MSM	Masoud AL Marri				
MMS	Mohammed AL Shehri				
AMA	Ahmed Alahmed	MATERIAL:		DWG Name.	
		Pure Titanium		Pure Titanium Specimen	
				A4	
				SCALE:2:1	
				SHEET 1 OF 1	

**SOLIDWORKS Student Edition.
For Academic Use Only.**

TITLE: Torsional property of Nano-Structured Titanium for use in Biomedical Application

DWG Name: Pure Titanium Specimen

A4

SCALE:2:1

SHEET 1 OF 1

6 5 4 3 2 1

D

D

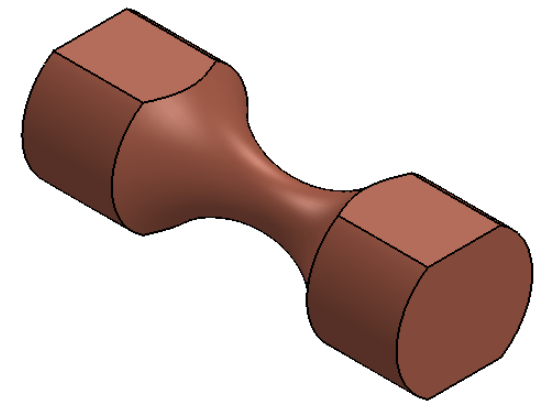
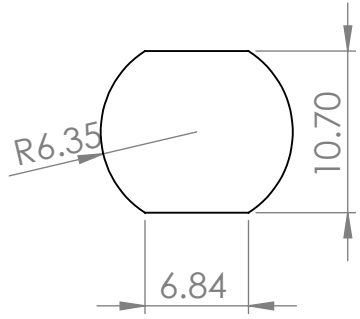
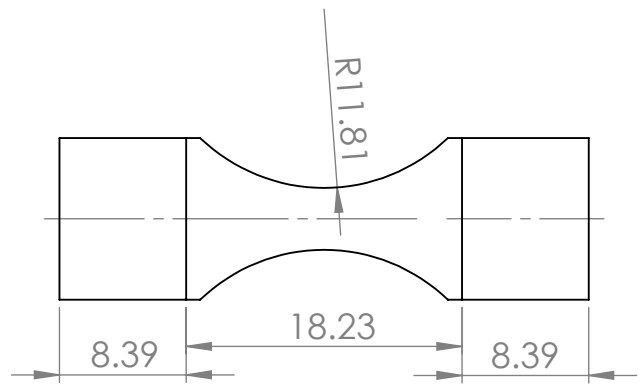

C

C

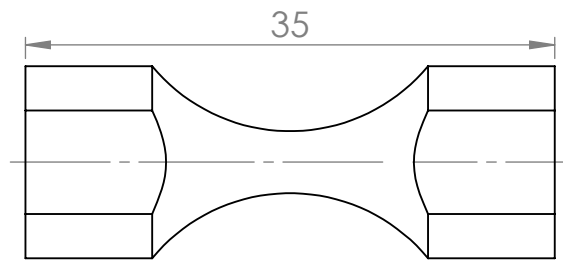

B

B

		Units mm			
	NAME			TITLE: Torsional property of Nano-Structured Titanium for use in Biomedical Application	
SMS	Saleh AL Shammari				
AAZ	Ahmed AL Zahrani				
MSM	Masoud AL Marri				
MMS	Mohammed AL Shehri				
AMA	Ahmed Alahmed	MATERIAL:		DWG Name.	
		Copper		Copper Small Spicemen	
				SCALE:2:1	SHEET 1 OF 1

**SOLIDWORKS Student Edition.
For Academic Use Only.**

Copper Small Spicemen

A4

6 5 4 3 2 1

A

A

6 5 4 3 2 1

D

D

C

C

B

B

A

A

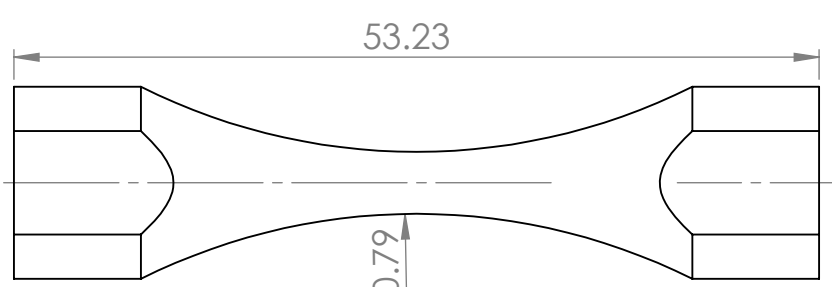
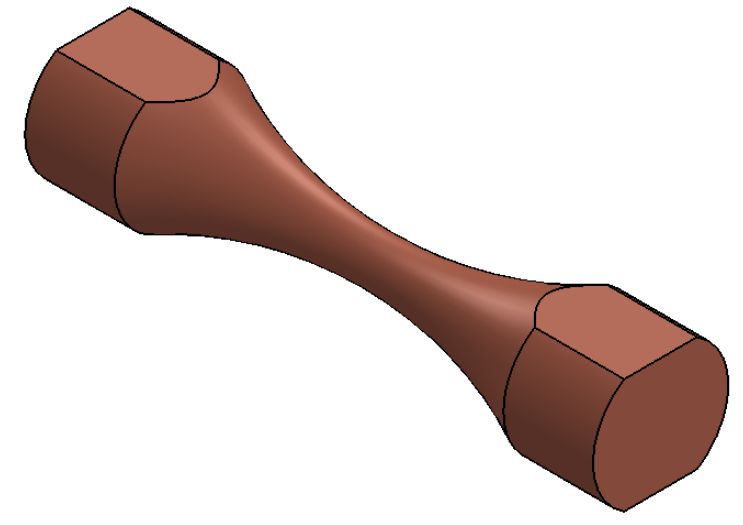
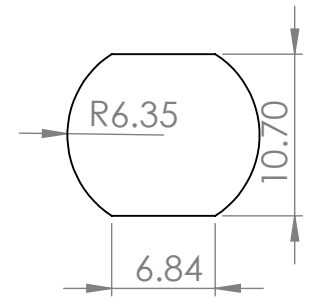
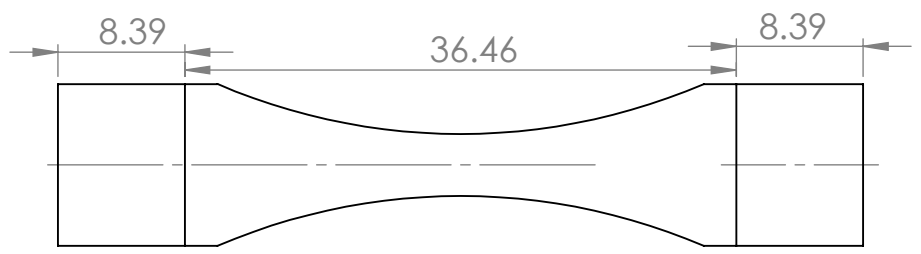

**SOLIDWORKS Student Edition.
For Academic Use Only.**

		Units mm			
	NAME			TITLE: Torsional property of Nano-Structured Titanium for use in Biomedical Application	
SMS	Saleh AL Shammari				
AAZ	Ahmed AL Zahrani				
MSM	Masoud AL Marri				
MMS	Mohammed AL Shehri				
AMA	Ahmed Alahmed	MATERIAL:		DWG Name.	A4
			Copper	Copper Large Specimen	
				SCALE:2:1	SHEET 1 OF 1

6 5 4 3 2 1

6

5

4

3

2

1

D

D

C

C

B

B

A

A

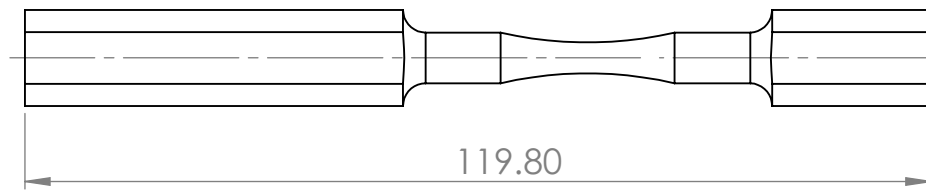
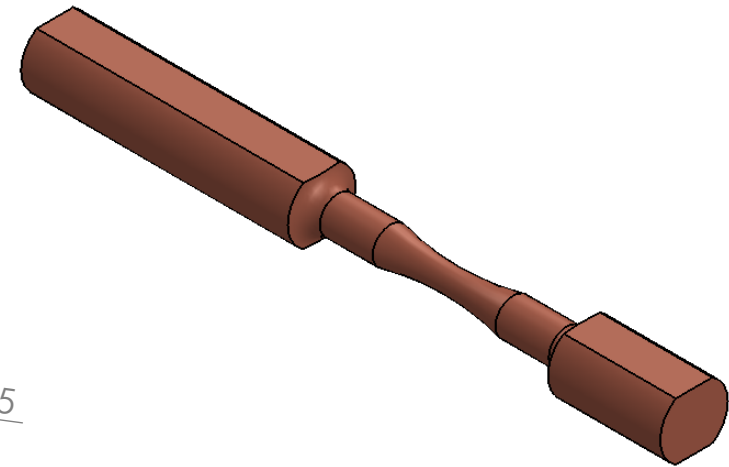
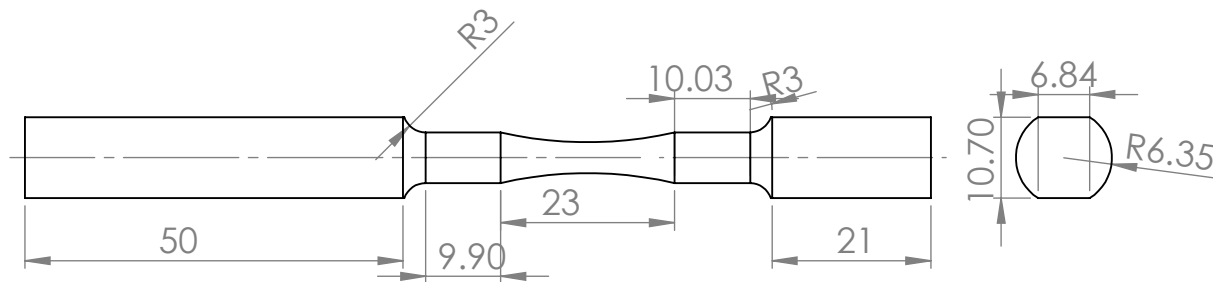

Units mm

		Units mm			
	NAME			TITLE: Torsional property of Nano-Structured Titanium for use in Biomedical Application	
SMS	Saleh AL Shammari				
AAZ	Ahmed AL Zahrani				
MSM	Masoud AL Marri				
MMS	Mohammed AL Shehri				
AMA	Ahmed Alahmed	MATERIAL:		DWG Name.	A4
			Copper	Copper Large Specimen Failed	
				SCALE:1:1	SHEET 1 OF 1

SOLIDWORKS Student Edition. For Academic Use Only.

Copper Large Specimen Failed

SCALE:1:1

SHEET 1 OF 1

6

5

4

3

2

1