



جامعة الأمير محمد بن فهد
PRINCE MOHAMMAD BIN FAHD UNIVERSITY

College of Engineering

Department of Mechanical Engineering

Spring 2016-17

Senior Design Project Report

Helical Wind Turbine

**In partial fulfillment of the requirements for the
Degree of Bachelor of Science in Mechanical Engineering**

Team Members

	Student Name	Student ID
1	Mohammed Alsayid	201300090
2	Ahmed Alramadhan	201200322
3	Mubarak Alwesmi	201202485
4	Muath Almansoor	201002152
5	Ameen Alnaseer	201100306

Project Advisors

Dr.Nader Sawalhi

Abstract

The project is about creating a Gorlov Vertical Wind Turbine and testing its performance. Throughout the course of the study, it is proven that the turbine is much more efficient than its predecessors due to the nature of it grasping wind, and harnessing its energy.

Conventional sources of power have become very expensive. Common street lights consume a lot of energy, this project aims to use the wasted energy of the wind to produce renewable energy source to produce enough power to light one or more street light. In this project we are going to design and assemble a helical wind turbine and attach it to one or more streetlights.

The project will consist of a helical type turbine with an electric generator attached to it directly via a coupling without the use of a gearbox allowing the system to be simple and applicable on a wide scale.

Acknowledgments

As we reach to the end of our journey at Prince Mohammed Bin Fahd University, we now have enough knowledge and skills as Engineers to implement them in the real world, thus we decided to undertake a project that represent our interest as Engineers, as well as enables us to implement what we learned. Moreover this project will provide us with a chance to gain more knowledge, such as aerodynamics and renewable energy.

We would like to take this chance to give our thanks first to our advisor Dr. Nader Sawalhi for his constant support and guidance throughout this course; also we would like to thank our professors and PMU staff for helping us to reach this level of knowledge and skills.

We also want to thank Almutakhaba workshop located in Dammam (Near to Dallah driving school) for their manufacturing of the project, and we would like to thank Mr. Omar for his assistance in manufacturing the project.

Table of Contents

Abstract.....	2
Acknowledgments	3
List of Acronyms (Symbols used in the report).....	6
List of Figures.....	7
List of Tables.....	8
Chapter 1	9
Introduction	9
1.1 Project Definition.....	9
1.2 Project Objectives	9
1.3 Project Specifications.....	10
1.4 Applications	11
Chapter 2	12
Literature review.....	12
2.1 Background.....	12
2.1.1 History of Renewable Energy	12
2.1.2 Wind turbine	13
2.1.3 Types of Wind Turbines	16
2.1.4 Horizontal and Vertical turbine.....	17
2.1.6 Small Scale Wind Turbine	18
2.2 Previous Work	20
2.3 Comparative Study	22
Chapter 3	27
System Design	27
3.1 Design Constraints.....	27
3.2 Design Methodology.....	28
3.2.1 Turbine sizing and estimation of power	28
3.2.2 Wind pressure and Static Loading	37
3.2.3 Shaft sizing	38
3.2.4 Bearing Selection	41
3.2.5 Thrust Bearing Features.....	44
3.3 Product Subsystems and Components	45
3.3.1 Generator selection	45
3.3.2 Brake design.....	47
3.4 Implementation	49
3.5 Final Design Assembly (2D Drawing).....	49
Chapter 4	50
System Testing and Analysis.....	50
4.1 Static Simulation.....	50
4.2 Dynamic simulation.....	51
4.3 Testing	53
Chapter 5	54

Project Management	54
5.1 Project Plan	54
5.2 Contribution of Team Members	54
5.3 Project Execution Monitoring	55
5.4 Challenges and Decision Making	56
5.5 Project Bill of Materials and Budget	56
Chapter 6	58
Project Analysis	58
6.1 Life-long Learning	58
6.2 Impact of Engineering Solutions	60
6.3 Contemporary Issues Addressed	61
Chapter 7	63
Conclusions and Future Recommendations	63
7.1 Conclusions	63
7.2 Future Recommendations	63
References	65
Appendix A: Datasheets	67
Appendix B: 2D Drawing of Parts	93

List of Acronyms (Symbols used in the report)

ρ : Air density

R : Gas constant which is $287.05 \frac{J}{Kg} K$

t : Temperature of air in Kelvin

λ : Tip speed ratio

r : Turbine radius

ω : Angular velocity

V : Wind velocity

C_p : Power coefficient

A : Area

P : Power

σ : The solidity

B : Number of blades

c : Chord length

d : Diameter of the turbine

$\sigma_{x,y}$: Stress

P_w : Wind load on the blade

W : Weight of the turbine

T : The torque

J : Polar moment of inertia

n : Factor of safety

S_y : Yield Strength

F_D : Desired Design Load

l_D : Desired Life

C_{10} : Catalog Load Rating

C_0 : Static Load Rating

List of Figures

Figure 1.1	Permanent Magnet Generator	10
Figure 2.1	Blyth's Wind Turbine	14
Figure 2.2	Blade Profile	16
Figure 2.3	Vertical and Horizontal Turbine	17
Figure 2.4	Rotor Shaft and Generation unit	18
Figure 2.5	Different Types of Vertical Turbine	22
Figure 2.6	Different Blade Types of Vertical wind Turbine	24
Figure 3.1	Average Temperature in AlKhobar	29
Figure 3.2	Gorlov Turbine	31
Figure 3.3	Power at Different Speeds	34
Figure 3.4	NACA 0018 Profile	35
Figure 3.5	Wind Load at Different Speed	37
Figure 3.6	Shaft	38
Figure 3.7	Deep Groove Ball Bearing	43
Figure 3.8	Thrust Bearing	44
Figure 3.9	Generator	45
Figure 3.10	Power at Different Wind Speed	46
Figure 3.11	Breaking Mechanisms	47
Figure 3.12	Braking Pedal	48
Figure 3.13	Brake Housing	48
Figure 3.14	Assembly 2D Drawing	49
Figure 4.1	Static Simulation (1)	50
Figure 4.2	Static Simulation (2)	51
Figure 4.3	Behavior Corresponding to Frequency number (1)	52
Figure 4.4	Behavior Corresponding to Frequency number (2)	52
Figure 4.5	Behavior Corresponding to Frequency number (3)	52
Figure 6.1	Anemometer	59
Figure 6.2	Tachometer	59
Figure 6.3	Voltmeter	60

List of Tables

Table 2.1	Time Line of Wind Turbine History	15
Table 3.1	Weather Information in AlKhubar	29
Table 3.2	Power at Different Speed	34
Table 3.3	Dimensions and Load Rating for Ball Bearing	42
Table 3.4	Dimensions and Load Rating for Thrust Bearing	43
Table 4.1	Dynamic Simulation	51
Table 4.2	Testing Results	53
Table 5.1	Project Timeline	54
Table 5.2	Work Distribution	55
Table 5.3	Bill of Materials (BOM)	57
Table 5.4	Project Budget Breakdowns	57

Chapter 1

Introduction

1.1 Project Definition

This project is intended to design and manufacture a simple wind turbine to be attached to streetlights in order to provide enough energy to light one or more. The design consists of a helical wind turbine coupled with an electrical generator, which will be attached to a battery to store the excess energy. The project aims not only to use a clean source of energy to power everyday needs, but also to provide a cost reduction in the large amount of funds that are spent yearly on generating power. The turbines that are going to be created are safe in nature, and are very cost efficient. The efficacy in cost will allow for many people to easily get a hold of them and for larger scale needs such as to power companies, as well as powering regular everyday things.

This project will prove to be very beneficial for the country as a whole, considering how the country has recently had a problem with the fluctuation of the oil prices. The project will easily be able to counter this issue, by introducing a new more reliable source of energy.

1.2 Project Objectives

The project aims to tackle some key features in order to ensure its success, these features are as follows.

- Design and construct a wind turbine to produce renewable energy which will reduce the pollution.
- Cut the cost of Lighting Street especially on highways and remote areas.

- Reduce the use of wiring to light the streets.
- Decrease the demand factor for the whole city.
- Allow the creation of mentioned turbine to be cost effective.
- Tailoring various different needs of power rather than just one.
- Make it accessible and easy to use by others.

1.3 Project Specifications

The project consists of various different components in order to put it together, and allow it to work effectively. These components include blades, two blade supports, shaft, battery and a manual breaking system, as well as thrust bearings. The thrust bearing however needs a custom housing to be included in it in order for it to work effectively. The skeleton of the project is then coupled to the permanent magnet generator as shown in figure 1.1, which will serve as the main source of power to the machine. The permanent magnet generator allows us to eliminate the need of using a gearbox.

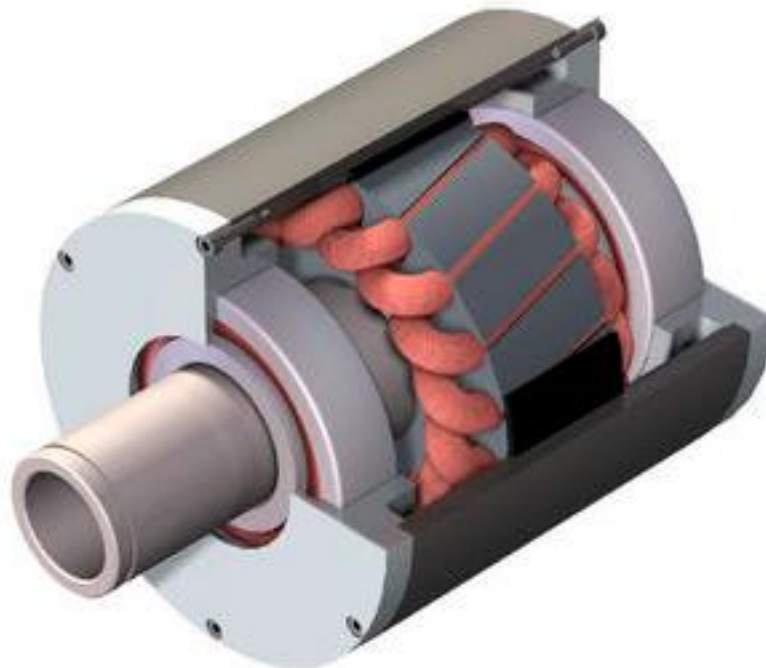

Figure 1.1
Permanent Magnet Generator

1.4 Applications

The turbine will serve various different applications to ensure that it gives the best possible results. These applications are as follows.

- Powering streetlights.
- Charging stations in walking areas.
- Used as a secondary source of power in houses.
- Can replace solar panels in areas where dust is common.

Chapter 2

Literature review

2.1 Background

2.1.1 *History of Renewable Energy*

It was once natural energy, then fossil fuel energy, then back to the natural or renewable energy. In other words, before it was a history of renewable energy, there were the natural sources of energy: wind, water and animals. These forms of powers had propelled several activities in ancient civilizations before 2000 BC including the Mesopotamian, Ancient Egyptians and ancient Chinese civilizations (Renewable Energy World, 2014) [1]. This is because energy has always been the want and need of people since long time ago. Because of this and through time, people went on developing and making use of the natural or renewable sources of power like the windmills, vapor turbine, and until they reached to fusel fossil oil. Then, about forty years ago and after technology advanced enough in several areas, researchers have reached to and kept developing solar energy from the sun as the cheapest and effective one. It is a fact that the energy which the sun supplies to the earth every day is much greater than any other energy used. The cost of the solar energy after researches advanced in this direction, can be cut by use of the photovoltaic's (PV) that uses common metals and this way solar energy will compete with fossil fuel energy generation.

Fossil fuel which is coal, petroleum and natural gas started to replace natural sources of powers: wind, water and animals mid the 19th century (AWEA, 2013) [2]. Coal was the first fossil fuel to be exploited and it was in China back 3490 BC until the Japanese governments in 1868-1912 realized the use of coal in propelling industrialization, encouraged the

development of coal mines. While oil was discovered first by Edwin Drake 1859 who drilled the first oil well in Pennsylvania, USA to mark the history of oil. Along with the discovery of oil, natural gas came to be used as a component of oil stock.

People used wind, water and animals as propeller several activities including sailing dhows, as watering mills in irrigation, farming works and for transporting loads. For more than two millennia 2000 years, wind-powered machines have ground grain and pumped water in fields (AWEA, 2013)[2]. Wind power was widely and always available and not confined to the banks of fast-flowing streams like water, or later, requiring sources of fuel. Wind-powered pumps that time drained the polders of the Holland, and in arid regions such as the American coasts and mid-west or the Australian coasts, as well as wind pumps provided water for livestock and steam engines.

2.1.2 *Wind turbine*

Wind turbine then followed to make use of the wind power and its ability to make employing the air flows that occur naturally in the earth's atmosphere (Renewable Energy World, 2014)[1]. Wind turbines were set on as windmills first whose blades capture this kinetic energy from the wind and turn it into mechanical energy, spinning shafts that moved the lever of pocket. Windmills had only a main drawback which was the seasonality of the wind.

James Blyth began a research program on the use of wind power for electricity generation and storage in the garden of his holiday cottage in Scotland. The wind turbine is created by Blyth was 10-meter high, cloth-sailed wind turbine and he used to charge accumulators developed by the Frenchman Camille Alphonse. Blyth's wind turbine design was 10-meter in diameter and stored the electricity generated in 'accumulators' batteries.

Blyth used the generated power to light his cottage, and even offered the surplus electricity to the people of the village for lighting the village's main street. Surprisingly, his village people turned down the offer as they thought electricity was 'the work of the devil'. Blyth later was able to install a larger wind turbine, which was much-improved version of his first at the Infirmary and Dispensary, where it ran successfully for 30 years. [3]

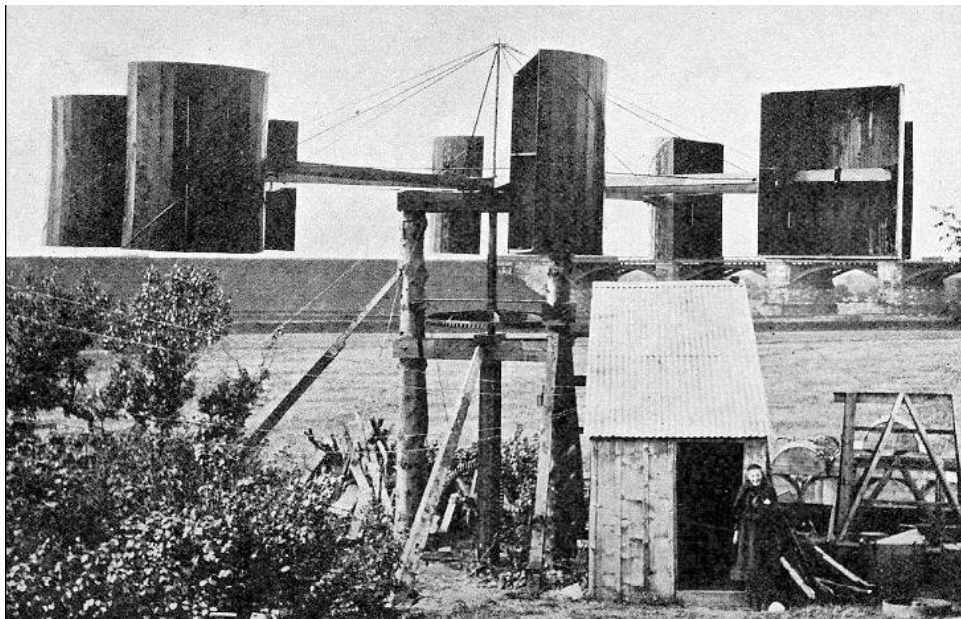

Figure 2.1
Blyth's wind turbine

Considering sources of renewable energy was prompted by the depleting reserve of fossil fuel, environmental issues resulted from it, economic motives and also advance in technology in several fields (Renewable Energy World, 2014)[1]. These factors combined to lead to the steady improvement and optimization of electricity generation wind turbine over time as shown table 2.1 below:

Table 2.1
Time line of wind turbine history

Jul 18, 1887	First electricity producing windmill built in Scotland by the Scottish Professor James Blyth in Glasgow, Scotland.
Jan 1, 1891	A new style of wind turbine by the Danish inventor Poul La Cour who incorporate modern aerodynamic design principles, with capacity of 25 kilowatts
Dec 31, 1900	Turbines produce 30 megawatts by Dutch that had 2500 turbines that are estimated to have produced, at their peak, 30 megawatts.
Jan 1, 1920	The first vertical-axis rotor invented by Frenchman George Darrieus.
Aug 18, 1941	Interest in wind energy decreases after WW2 as a result of cheaper fossil fuels as a result of the fall in fossil fuel prices after World War II
Aug 18, 1960	World first mega-watt turbine built in Vermont USA built to the power grid in Castleton, Vermont USA.
Oct 18, 1973	Advanced horizontal axis turbine designs technology in places such as Germany, consisting of fiberglass and plastic blades with variable pitch blades thus increasing efficiency.
Aug 18, 1980	The oil crisis creates a new interest in large wind turbines and government-sponsored renewable energy research programs start in Germany, Sweden, Canada, Great Britain and the US.

More literature on wind turbine is given by Alsayed (2014) [4]. The turbine is a machine which converts rotational energy into usable work or usable energy according to Alsayed as the change is initiated through mechanical gearing or because of electromagnetic induction, which results in electricity. As a term, there are different terms for different types of turbines including: steam turbines, gas turbines, water turbines and wind turbines; a source of energy is that is becoming more widely used. Wind turbines as the topic of discussion are powered by movement of air that propels the blades or rotors of the turbine, which are generally referred to as airfoils. They are designed to react with wind and capture rotational power that is converted to energy. The shape of the blade has a great effect as it causes pressure to be uneven, higher on one side than on the other, making the blade spin.

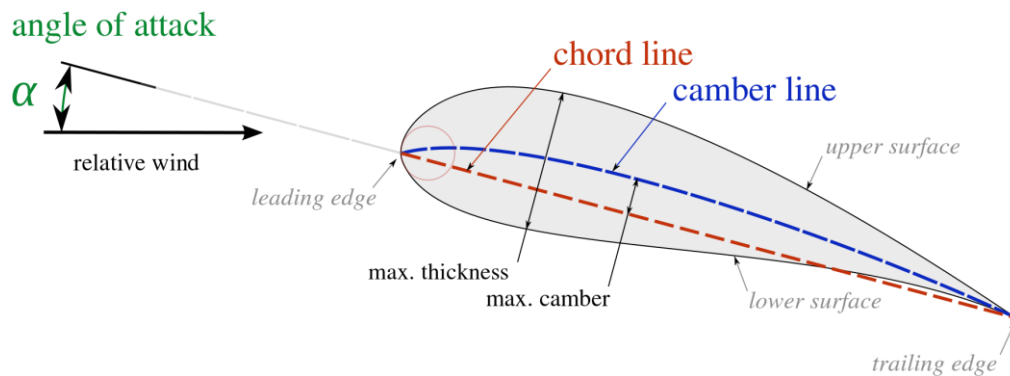

Figure 2.2
Blade Profile

2.1.3 Types of Wind Turbines

A. Types by scale (size and capacity):

From by size and capacity aspect, there are three major types of wind power which are:

- First: large (utility-scale wind) turbines as larger than 100 kilowatts and developed with electricity delivered to the power grid and distributed to the end user by electric utilities or power system operators.
- Second: small wind turbine, which is the type that uses turbines of 100 kilowatts or smaller to directly power a home, farm or small business as its primary use.
- Third: offshore wind, which are wind turbines mounted in bodies of water surfaces around the world where winds are stronger.

B. Types by rotation/wind flow angle:

The two main types of wind turbine are based on the direction/effect of the wind flow as Alajmi, Jelowi, Alsayed & Tareq (2014) [4] introduce them. The first type of wind turbines: horizontal axis wind turbine (HAWT) and second is the vertical axis wind turbine (VAWT).

Figure 2.3 below illustrates the structure of each considering the wind flow direction:

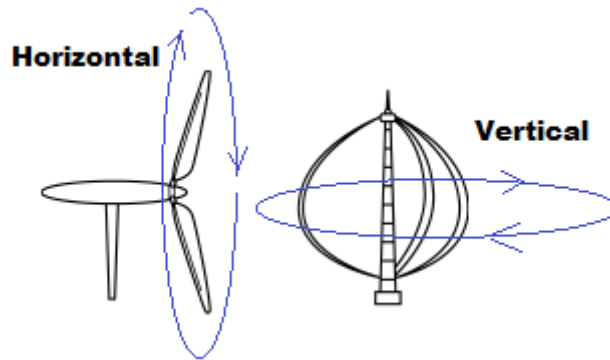

Figure 2.3
Vertical and horizontal turbine

2.1.4 *Horizontal and Vertical turbine*

The horizontal HAWT turbine can be mounted on a large tower and has in general two or three blades and its axis is parallel to the wind flow. The difference in wind speeds on the top and bottom side creates a difference in pressure between the blade surfaces so that an aerodynamic lift is produced or in other words rotation happens. Thus, there exists a drag force perpendicular (upright) to the lift force which opposes the rotation of the blade.

2.1.5 *Additional components of wind turbine system*

Converting wind power to electric energy is discussed by Casini (2016). A stand-alone VAWT systems that can be connected systems with other energy conversion systems like the solar photovoltaic (PV) placed on rooftops, on streets or in gardens, is the subject of this design. The integration of renewable resources in buildings is a key aspect of the 21st-century architecture and to achieve zero energy buildings (ZEB), we need to reduce the consumption of fossil energy in order to cut carbon emissions in urban areas. Besides photovoltaic systems, there are the Vertical Axis Wind Turbines, as business growing globally. Solar cells, also called photovoltaic (PV) cells by scientists according to Casini, convert sunlight directly

into electricity. PV gets its name from the process of converting light –latin photo and its units photons to electricity voltage, which is known as the PV effect. The wind turbine in the end produces the rotary motion that is converted to electric power at the generation unit shown in figure 2.4 below:

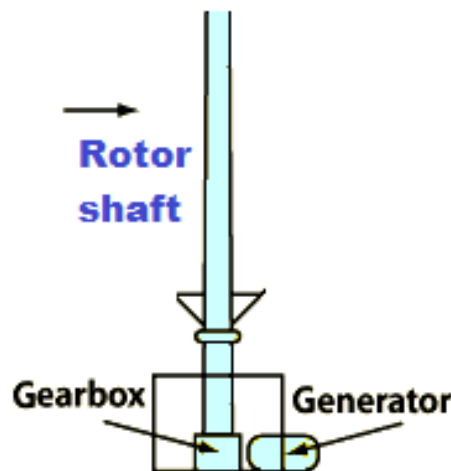

Figure 2.4
Rotor shaft and generation unit

2.1.6 *Small Scale Wind Turbine*

These small scale wind generators (200 W – 1 kW) can be used in this design as stand-alone systems or as grid connected systems, and both can be paired with other energy conversion systems, such as photovoltaic (Casini, 2016). With a height from 2 to 10 meters from ground, small wind turbines can be placed on rooftops, on streets or in gardens, with relatively little visual impact but able to produce energy even from modest wind flows. These small wind turbines may also be coupled to street lighting systems as smart lighting. The analysis of the different types of vertical wind turbines available on the market, what products, and how it is possible to install them on buildings and the benefits achieved in terms of energy production compared to photovoltaic systems.

The conclusion in the study experimented by Casini (2016) is that, small vertical wind turbines can be an effective solution for the production of renewable energy with the aim of

promoting zero energy buildings and the urban model of distributed power generation. In relation to the influence of wind conditions on turbines' performance, the study found it confirming that to identify architectural forms able to maximize the eventual production of wind energy (BAWT). But to carry out a thorough environmental analysis of the wind resource prior to the installation in order to identify the most suitable turbine model and its optimal location. Another finding is that, a true comparison between different products and to direct users and developers in relation to the environmental characteristics of the site.

A domestic VAWT system is the focus of this design is discussed by Rishmany, Daaboul, Tawk† & Saba (2017) [6] where an appropriate airfoil geometry and the optimum number of blades are selected from a series of wind tunnels. Wind as a renewable energy source according to the researchers is not yet fully exploited despite the permanent availability of this source. In addition, in countries where renewable energy regulations are still absent, large scale application is still non-applicable. In this case, a Domestic vertical axis VAWT wind turbine is designed and tested. Design stages first included a series of wind tunnel tests in for the purpose to select the appropriate airfoil geometry and the optimum number of blades. Scaling was then applied in order to obtain a desired output power. The process in general is described as an optimization of system performance where appropriate component selection was realized with the help of a multi-body dynamics analysis tool and finite element analysis.

2.2 Previous Work

About the maintenance problem of wind turbine Alsayed (2014) [4] states that prolonged exposure to wind and atmospheric factors leads to material decay due to turbulence, wind gusts, and wind shear leads to bending stresses along the chord length and using carbon fiber rather than fiber-glass is expensive. Larger blades harvest more energy, but have faster tip speeds and therefore, create more noise as well as they create stress on mechanical and gear components. The solution composes of painting the airfoils with special materials as protection that will protect the leading edges from erosion and extend the lifespan of the airfoils, reduce maintenance costs and, most importantly, increase blade efficiency.

Alternative materials according to Alsayed study can be used according to the article, that have the same properties as carbon fiber as an effective alternative is COC, cellulose nano-crystals which are stronger, lighter cheaper than carbon fiber even though less available. Also, increasing the dimensions of the turbine blades increases the surface area and distributes loads along a larger surface that will in return help in reducing the bending stress and wind shear. A measure to take also to limit the noise from the rotor blades and gearbox a damping system especially in large turbines it can be installed that will produce counter vibrations to decrease the amount of noise produced. Since using large blades causes micro-pitting on gear teeth, the use of advanced additive technologies can be used and will stop further micro-pitting formation in the structure.

As the dimensions of wind turbines increase according to Alsayed study, a design factor is new methods of load control are needed to decrease the stress levels on turbine blades.

Experimental studies in the field of wind turbine blade research showed the morphing

concept is significant for wind turbine technology. The reason is because at critical loads it reduces stress levels. It allows for building structures that have the conflicting abilities of being load carrying while keep being efficient, lightweight and shape adjusted and here a composite plate is inserted into the airfoil section along the chord line and the leading edge of the composite plate is clamped at its center to a vertical spar. The trailing edge of the plate in standard designs is hinged to a vertical web, which is also hinged to the airfoil surfaces for the purpose of allowing relative movement of the skins during rotation. Rotation the composite plate in standard designs, means the camber of the airfoil section is morphed between two different stable shapes.

A car-mounted Small Vertical Axis Wind Turbine (VAWT) for generating electricity is the focus of this prospect by Khan, Moniruzzaman, Feroz & Islam (2012) [7]. The hybrid vehicle technology and its integration with wind energy with the main objective of this project being to design and fabricated a self-starting small vertical axis wind Turbine (VAWT). The study proposes that VAWT can be mounted over the roof of the car or in front other cooler. It is because a car moves through a layer of fluid which always is a disadvantage for the moving car as it poses a drag force due to moving forward. In the research project, the researcher uses this car motion force for developing electrical energy which is built to achieve RPM at minimum wind speed. The Twisted blade o the turbine is the main function which plays the role to rotate it at minimum wind speed of the car. The researcher's optimized view for this project is to set this VAWT in a car and run it by wind where 11.77 watt power can be generated when the turbine is run at 112 rpm speed for the wind speed is 6m/h. As theoretical approach, the design applies the -lift and drag force that states "the lift and drag coefficients are dependent on the Reynolds number and the angle of attack"

The conclusion presented by Khan, Moniruzzaman, Feroz & Islam (2012) is that to achieve RPM at minimum wind speed, a drag force of the windflow produced by the car motion should be used. The Twisted blade of the turbine is the main function which plays the role to rotate the shaft it at minimum wind speed. The experiment optimized view for this project is to set this VAWT in a car and run it by wind and gave positive result considering the experiment 11.77 watt power can be generated when the car's turbine is run at 112 rpm for the wind speed is 6m/s

2.3 Comparative Study

The vertical VAWT turbine has its rotor positioned vertically. The advantages of VAWT turbines become clear when operating at a low speed. There are mainly two main types of vertical VAWT: Savonius and Darrieus. The Savonius wind turbine is well known to be a drag type turbine. This vertical type of turbine has low efficiency in general but it is suitable for areas with turbulent wind. The Darrieus vertical wind turbine needs a motor to start its motion. It is also well suited for places with turbulent wind gusts where it shows high efficiency in such conditions.

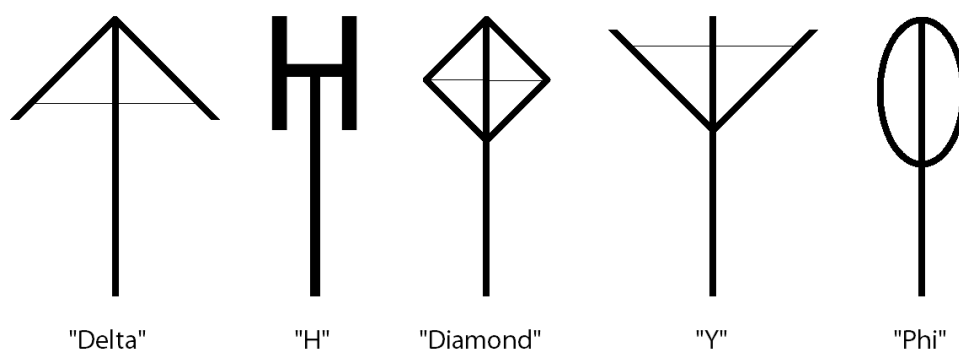

Figure 2.5
Different types of vertical turbines

Rishmany, Daaboul, Tawk† & Saba (2017) found that the Savonius type turbine is not efficient in terms of output power; however, the advantage of such a type of turbine lies in the operating range because this VAWT can operate under low wind speeds. One finding, the recorded a power of 22 Watts with an ideal generator that had no rotary resistance at a wind speed of 8 m/s. The actual results found at a wind speed of 8.5 m/s recorded an output power of 14.5 Watts which is acceptable. The results; are comparable and it can be seen that a mechanical loss of 7.5 W generated by the friction and the vibrations of the turbine if the power recorded in other MSC ADAMS studies is taken as a reference. In conclusion, the manufacturing and testing of a Savonius VAWT type was done, the selection of the Savonius type VAWT is due to the fact that it can operate under low wind speeds. Rishmany, Daaboul, Tawk† & Saba concluded that, a dynamic simulation using the reference to get the configurations of the generator and the forces on the connecting joints and a stress analysis using MSC PATRAN were conducted in order to estimate the performance and to verify the structural integrity of the turbine. Then the turbine was assembled and tested by using a wind tunnel environment in order to control the consistency of the testing conditions and to avoid the fluctuating natural wind, a series of measurement apparatus were used in order to get the wind speed just before the turbine and the corresponding torque and rotational speed of the turbine. The test results were found to be in accordance with the theoretical results and the method will enable sizing wind turbines of higher power outputs.

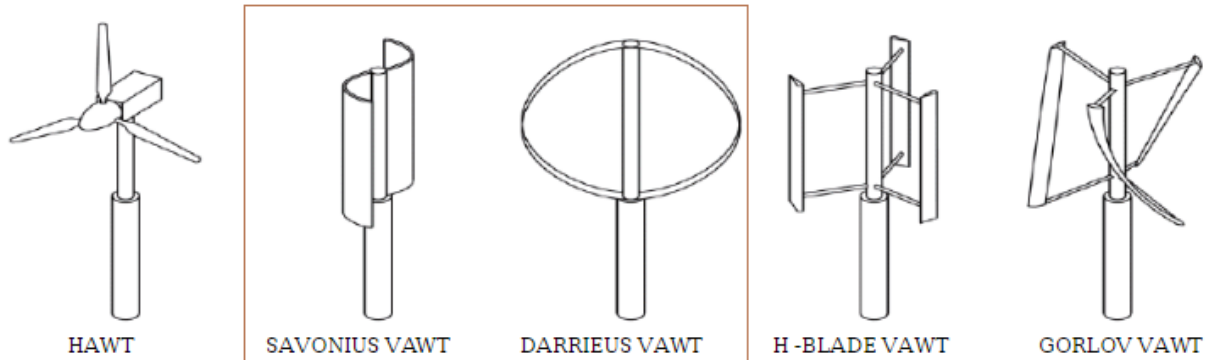

Figure 2.6
Different blade types for vertical wind turbines

For this purpose, every wind-turbine designer settles on different blade geometry for a particular model. Therefore, for best blade performance improvements, the Vortex Generators (VGs) design and installation must be custom-made for each model blade. To identify the best VG positions from the several possible designs, it is necessary to investigate the blade's aerodynamic performance. The analysis led to the “smart blade” development as a proprietary flow analysis that involves flow visualization and advanced image processing.

Using Vortex Generators (VGs) is found to improve wind turbine performance in a study by Dvorak (2016) as the power, loads, and service life of the wind turbine are precisely attached to turbine blades. The Dvorak test, the flow analysis was performed where the Vortex Generators (VGs) were installed close to the blade root and angled to the leading edge.

The purpose of the VGs is to eliminate the flow separation at the inner part of the blades and return the blade to the “as-designed” position. This structure is found to contribute little to loads as they might on outboard region of the blade as determined to decrease flow separation without further increasing drag.

Blade design goal is finding the right blade geometry that generates the most rotary action.

Blade design considers the wind turbine parameters is based on 6 factors which are: (Ragheb, 2015)

- Swept area
- Power and power coefficient
- Tip speed ratio
- Blade chord
- Number of blades
- Angle of attack

The first which is the swept area is the section of air that encloses the turbine in its movement, the shape of the swept area usually depends on the rotor configuration, this way the swept area of an regular HAWT has to be of circular shaped and for a regular straight-bladed vertical axis wind turbine the swept area has a rectangular shape and is calculated using: $(S = 2 R)$ where S is the swept area [m]. The second which is power available from wind for a vertical axis wind turbine can be found from the following formula

$P_{wind} = \frac{1}{2} \times C_p \times A \times V^3$ Where available power is dependent on the cube of the airspeed; and the turbine takes from wind is calculated using the power coefficient. The third which is the power coefficient is directly dependent on tips peed ratio, and defined as the ratio between the tangential speed at blade tip and the actual wind-speed. The third which the chord is the length between leading edge and trailing edge of the blade profile or the plane of rotation as the blade tips lie as they rotate since they actually trace out a circle which lies on the plane of rotation. The fifth which is the number of blades because it has a direct effect in

the smoothness of rotor operation and compensate cycled aerodynamic loads and therefore in building, four and three blades maybe chosen.

Chapter 3

System Design

3.1 Design Constraints

- Engineering-wise, this project requires a lot of parameters to be taken into account, because the helical turbine design has numerous variables that needs to be optimized, such as the blade profile, the inclination angle, twist angle, chord length, height, and width.
- As for sustainability, the helical design puts a lot of cyclic stress over the turbine blades, thus, not all materials are suitable for the design, metallic design may not be compatible with such loads, and thus, composite materials are more suited for this design as they are less prone to fatigue caused by cyclic stresses. The system also needs maintenance for the electric generator, which will be a permanent-magnet type in order to eliminate the use of gearbox. Also the system contains a large battery to store produced energy, the battery needs to be maintained.
- Economically, this project is more ideal on a small scale implementation, as installing the system on a wide scale, street lights for example, is not cost-effective, thus, this the system more suited on smaller scales such as rural areas where producing and transmitting sufficient energy can be very expensive and harmful to the environment.
- As for manufacturability, this project does not have many constraints, blades are made out of ductile material such as aluminum or composite material and

the energy is transmitted to a battery, both of which can be easily manufactured and obtained.

- As for time, we were challenged to come up with design parameters and manufacturing all in one semester, without prior knowledge of aerodynamics.
- The turbine requires an open area, preferably on a high mounting point in order for the wind to have sufficient velocity to spool the blades.

3.2 Design Methodology









3.2.1 Turbine sizing and estimation of power

The parameters fall primarily into two categories, namely those governed by the geometry of the turbine, and those governed by the flow field in which the turbine is designed to be placed. In general, the environmental parameters, or the parameters governed by the flow field in which the turbine is to be placed, are fixed and the designer has little option to change any of them in an attempt to increase efficiency. These parameters include important values such as the free stream velocity, and the density of the air. These parameters will be shown in section 3.2.1.1

3.2.1.1 Local area weather

Table 3.1
Weather information in AlKhubar [8]

Al Khobar, Saudi Arabia historical weather on 26th May over the years

Date	Weather	Max Temp	Min Temp	Wind	Precip	Humidity	Pressure
2009		46 °c	33 °c	9 mph SE	0.0 mm	14%	998 mb
2010		39 °c	29 °c	16 mph NNW	0.0 mm	24%	1006 mb
2011		37 °c	31 °c	15 mph N	0.1 mm	30%	1005 mb
2012		38 °c	30 °c	18 mph N	0.0 mm	37%	1006 mb
2013		37 °c	29 °c	6 mph ENE	0.0 mm	33%	1004 mb
2014		40 °c	33 °c	13 mph NNE	0.0 mm	38%	1006 mb
2015		39 °c	33 °c	8 mph ESE	0.0 mm	29%	1007 mb
2016		36 °c	29 °c	17 mph NNW	0.0 mm	38%	1006 mb

Al Khobar, Saudi Arabia Yearly Monthly Weather Averages

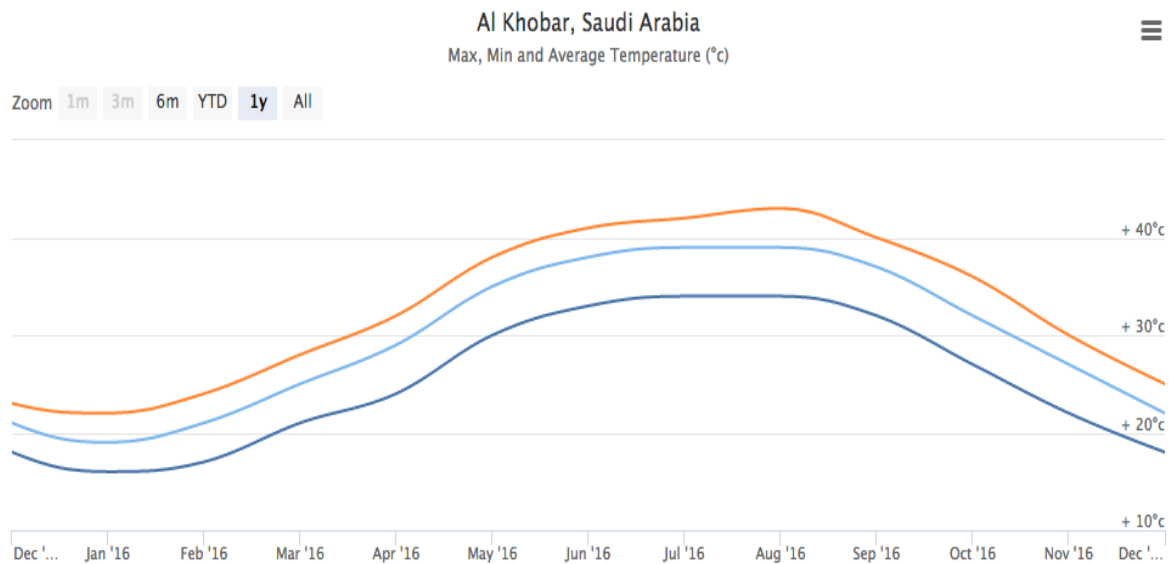

Figure 3.1
Average temperature in AlKhubar [8]

As shown in the table 3.1, the average wind speed in AlKhubar in 2016 is 8 m/s , also as shown in figure 3.1, the average temperature in AlKhubar in 2016 is 39°C , therefore the air density can be calculated using equation 3-1. [9]:

$$\rho = \frac{P}{R \times t} \quad \text{Equation (3-1)}$$

Where:

ρ : Air density

R : Gas constant which is $287.05 \frac{\text{J}}{\text{Kg}} \text{K}$

t : Temperature of air in Kelvin

$$\rho = \frac{101.325}{287.05 \times (39 + 273)}$$

$$\rho = 1.13 \text{ Kg/m}^3$$

3.2.1.2 Helical Turbine

The helical turbine, also known as the Gorlov turbine was our choice of design.

Figure 3.2 shows the turbine.



Figure 3.2
Gorlov Turbine

The dimensions we chose for the turbine are $1\text{ m length} \times 0.7\text{ m diameter}$, as they are convenient for a small-scale wind turbine.

Moreover, the parameter that the designer has an option to control, here, are some of the formula used to design the turbine and to maximize the efficiency.

“Albert Betz was a German physicist who calculated that no wind turbine could convert more than 59.3% of the kinetic energy of the wind into mechanical energy turning a

rotor. This is known as the Betz Limit, and is the theoretical maximum coefficient of power for any wind turbine” [10].

Therefore we assumed that $C_p \approx 0.55$

It was found that the tip speed ratio for Gorlov turbine falls between 2-2.5

“The natural tip speed ratios of the Gorlov helical turbine were found to fall within the range from 2 to 2.5 in all resources used, except Shiono et al. found the range to be just below 1 to 2.5. If this lower range is considered to be for not quite optimized circumstances and ignored, the tip speed ratio range of 2 to 2.5 can be used to predict possible expected angular velocities for our turbine using the relationship: [11]

$$\lambda = \frac{r \times \omega}{V} \quad \text{Equation (3-2)}$$

Where:

λ : Tip speed ratio

r : Turbine radius

ω : Angular velocity

V : Average air velocity

Rearranging equation (3-2) yields:

$$\omega = \frac{\lambda \times V}{r}$$

As mentioned in section 3.2.1.1 and 3.2.1.2

$$r = \frac{0.7}{2} = 0.35 \text{ m}$$

$$V = 8 \text{ m/s}$$

$$\lambda_{average} = \frac{2.5 + 2}{2} = 2.25$$

Thus the equation becomes:

$$\omega = \frac{(2.25 \times 8)}{0.35} = 51.4 \text{ rad/s}$$

The torque of the turbine can be calculated using the following equation:

$$T = \frac{(1/2 \times C_p \times \rho \times A \times V^3)}{\omega} \quad \text{Equation (3-3)}$$

Where:

$$A: \text{Area} = L \times d = 1 \times 0.7 = 0.7 \text{ m}^2$$

C_p : Power coefficient

ρ : Air density

V : Wind velocity

ω : Angular velocity

Then the torque becomes:

$$T = \frac{(\frac{1}{2} \times 0.55 \times 1.13 \times 0.7 \times 8^3)}{51.4} = 2.17 \text{ N.m}$$

The power of the turbine can be calculated using equation (3-4):

$$P_{flow} = \frac{1}{2} \times \rho \times A \times V^3 \quad \text{Equation}$$

(3-4)

$$P_{flow} = \frac{1}{2} \times 1.13 \times 0.7 \times 8^3 = 202.5 \text{ W}$$

$$P_{turbine} = P_{flow} \times C_p \quad \text{Equation (3-5)}$$

$$P_{turbine} = 202.5 \times 0.55 = 111.4 \text{ W}$$

Table 3.2 shows the power at different wind speeds:

Table 3.2

Power at different speeds

Velocity (m/s)	km/h	Diameter (m)	Length (m)	Area (m ²)	Power (W)
5	18	0.7	1	0.7	27.2
6	21.6	0.7	1	0.7	46.9
8	28.8	0.7	1	0.7	111.4
10	36	0.7	1	0.7	217.5
12	43.2	0.7	1	0.7	375.9
14	50.4	0.7	1	0.7	596.9
16	57.6	0.7	1	0.7	890.9

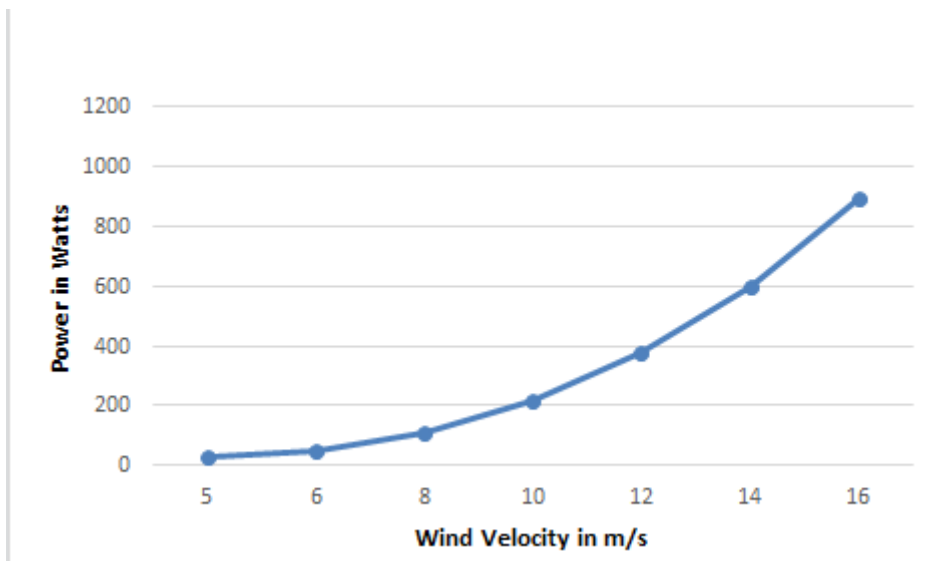

Figure 3.3

Power at different speeds

3.2.1.3 Blade Shape and Profile

Regarding the blade shape we decided to choose the NACA-0018.

The NACA0018 profile is the most efficient for the design of a vertical turbine functioning at low wind speeds.

We decided to go with NACA 0018 blade profile as it was used frequently in wind and marine helical turbine, NACA 0018 blade offers a medium between the optimized performance of a thin blade and the manufacturability and durability of thick blades profile. There is no need for a special cambered blade design because of the good self-start capability of the helical turbine [12].

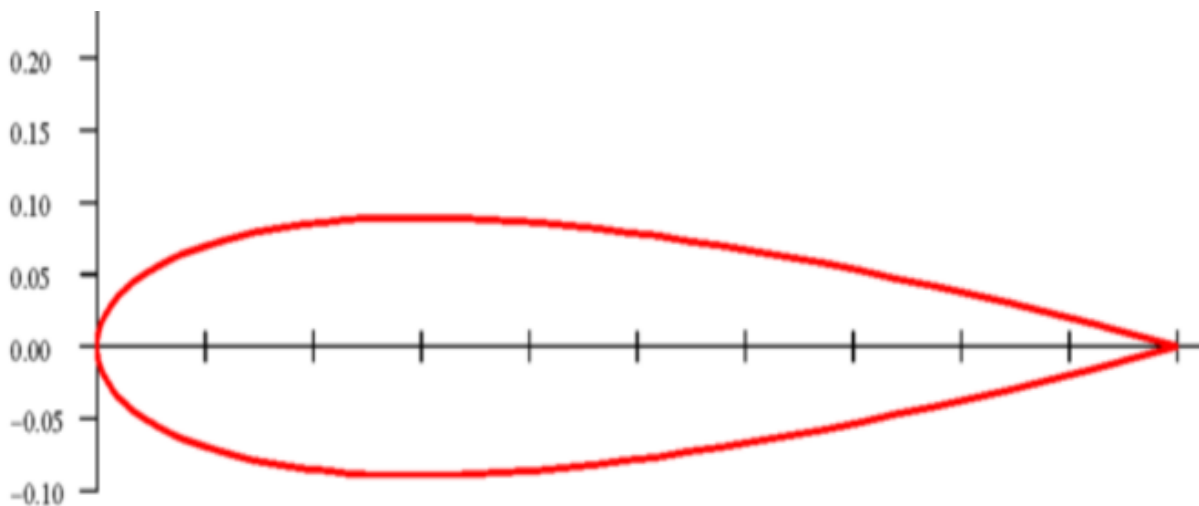

Figure 3.4
NACA 0018 Profile

According to Battisti, L., Brighenti, A., Benini, E., & Castelli, M. R ., the efficiency and controllability are affected by the solidity of the turbine, solidity is defined as σ , the developed surface area of all blades divided by the swept area of the rotor, it was found that at 0.15, as a good compromise between controllability and rotor efficiency and it is calculated by using equation (3-6) shown below. A turbine with high solidity allows to keep the

optimized turbine rotational velocity relatively low, which minimizes the rotor vibrations and maximizes the aerodynamic efficiency.

The solidity was chosen to be high, at around 0.15, the solidity then can be calculated using the equation:

$$\sigma = \frac{Bc}{\pi d} \quad \text{Equation (3-6)}$$

Where:

σ : The solidity

B : Number of blades

c : Chord length

d : Diameter of the turbine

Rearranging equation (3-6) yields:

$$c = \frac{\sigma \times \pi d}{B}$$

$$c = \frac{(0.15 \times 0.7\pi)}{3} \approx 0.11 \text{ m}$$

3.2.2 Wind pressure and Static Loading

According to Dyrbye, C., & Hansen, S. O wind pressure can be obtained through graph 3.5. [13]

Using wind velocity of 8 m/s, air density of 1.13 kg/m³, blade surface area of 0.119528145 m² calculated using SolidWorks, and with the help of special software linked to the graph, the wind load on a blade is found to be 36.2 N/m² [14], therefore the wind load is found using equation (3-7)

$$\text{Wind load} = \text{Dinamic pressure} \times \text{Blade area} \quad \text{Equation (3-7)}$$

$$\text{Wind load} = 36.2 \times 0.119528145 = 4.32 \text{ N}$$

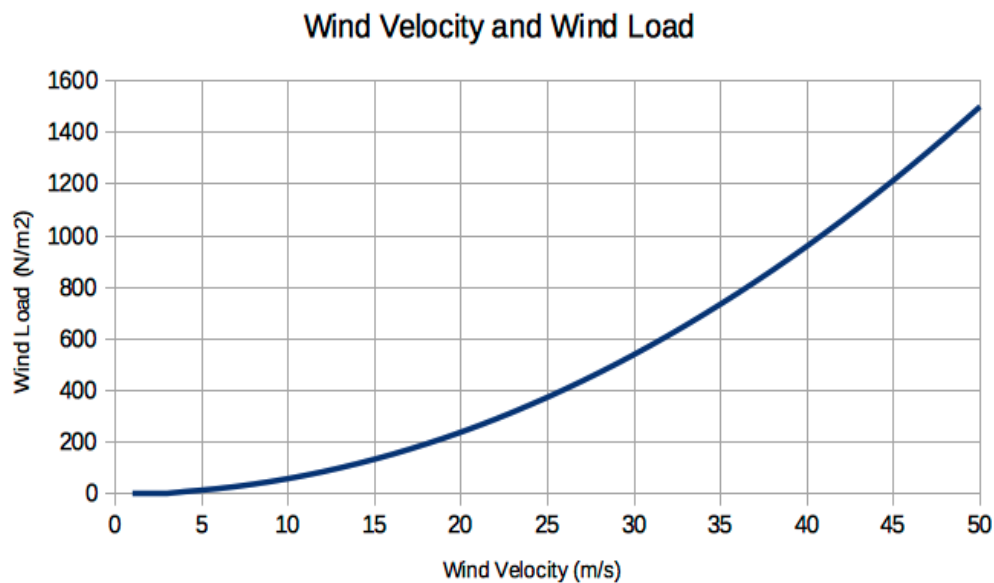

Figure 3.5

Wind load at different speeds

3.2.3 Shaft sizing

The shaft is subjected to two forces and a torque, the torque resulting from the rotation of the blades due to wind orthogonal to the shaft; the torque is previously calculated in section 3.2.1.2 and was found to be equal to $2.17 \text{ N}\cdot\text{m}$, the wind load calculated in section 3.2.2 which is equal to 4.32 N , and the turbine weight which is obtained through SolidWorks, was found to be 153 N

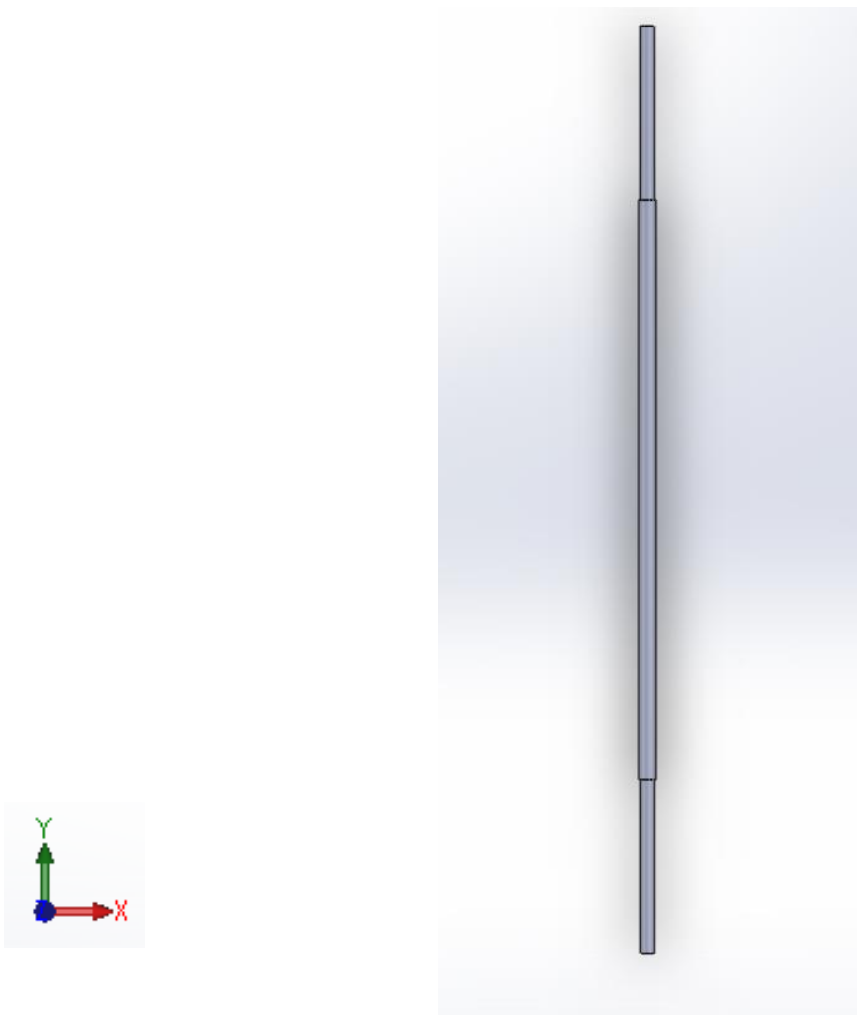

Figure 3.6
Shaft

Therefore, the stresses on the shaft are:

$$\rightarrow \sigma_x = \frac{P_x}{A} \quad \text{Equation (3-8)}$$

Where:

P_w : Wind load on the blade

A : Cross section area of the shaft

$$A = \frac{\pi d^2}{4} \quad \text{Equation (3-9)}$$

$$d = 0.025 \text{ m}$$

$$A = \frac{\pi(0.025^2)}{4} = 0.0005 \text{ m}^2$$

Therefore:

$$\rightarrow \sigma_x = \frac{4.32}{0.0005} = 8.6 \text{ kPa}$$

And

$$\downarrow \sigma_y = \frac{W}{A} \quad \text{Equation (3-10)}$$

Where:

W : Weight of the turbine

A : Cross section area of the shaft

Therefore:

$$\downarrow \sigma_y = \frac{153}{0.0005} = 306 \text{ kPa}$$

The torsion on the shaft can be calculated using the formula:

$$\tau = \frac{T \times r}{J} \quad \text{Equation (3-11)}$$

Where:

T : The torque

r : Radius of the shaft

J: Polar moment of inertia which can be found using equation (3-12):

$$J = \left(\frac{\pi}{2}\right) \times r^4 \quad \text{Equation (3-12)}$$

$$\text{Therefore: } J = \frac{\pi}{2} \times (0.0125^4) = 3.83 \times 10^{-8} m^4$$

Then the torsion becomes:

$$\tau = \frac{(2.17 \times 0.0125)}{(3.83 \times 10^{-8})} = 0.71 \text{ MPa}$$

The principal stresses then can be calculated using the equation [15]:

$$\sigma_1, \sigma_2 = \left(\frac{\sigma_x + \sigma_y}{2}\right) \pm \sqrt{\left(\frac{\sigma_x - \sigma_y}{2}\right)^2 + \tau^2} \quad \text{Equation (3-13)}$$

Hence:

$$\sigma_1 = \left(\frac{8.6 + 306}{2}\right) + \sqrt{\left[\frac{8.6 - 306}{2}\right]^2 + 710^2} = 731 \text{ kPa}$$

$$\sigma_2 = \left(\frac{8.6 + 306}{2}\right) - \sqrt{\left[\frac{8.6 - 306}{2}\right]^2 + 710^2} = -719.3 \text{ kPa}$$

Using Von Mises Stresses theory to calculate the factor of safety:

$$\sigma' = \sqrt{\frac{(\sigma_1 - \sigma_2)^2 + (\sigma_2 - \sigma_3)^2 + (\sigma_3 - \sigma_1)^2}{2}} \quad \text{Equation (3-14)}$$

Note that:

$$\sigma_1 = 731 \text{ kPa}$$

$$\sigma_2 = 0 \text{ kPa}$$

$$\sigma_3 = -719.3 \text{ kPa}$$

Therefore using equation (3-14):

$$\sigma' = 1.54 \text{ MPa}$$

Therefore factor of safety can be calculated using equation (3-15):

$$n = \frac{S_y}{\sigma'}$$

Equation (3-15)

Where:

$S_y = 28 \text{ MPa} = \text{Yield Strength [16]}$

n : Factor of safety

Therefore using equation (3-15) factor of safety becomes:

$$n = \frac{28}{1.54} = 18.2$$

3.2.4 Bearing Selection

Based on the types of forces acting on the shaft, that are radial and axial forces calculated in section 3.2.3, 4.32 N and 153 N respectively. We have selected a ball bearing to be installed on the top due to the radial force caused by the shaft rotation. Since we have a distributed load of 4.32 N acting on the blade, each bearing is subjected to an equal reaction force of 2.16 N, which is the radial force.

$$C_{10} = F_D \left[\frac{l_D n_D 60}{l_R n_R 60} \right]^{1/3}$$

Equation (3-16) [15]

Where:

F_D : Desired Design Load

l_D : Desired Life

C_{10} : Catalog Load Rating

C_0 : Static Load Rating

$$\frac{51.4 \times 60}{2\pi} = 490 = n_D$$

$$l_R n_R 60 = 10^6$$

$$\text{Therefore } C_{10} = 2.16 \left[\frac{5000 \times 490 \times 60}{10^6} \right]^{1/3} = 11.4 \text{ kN}$$

Thus from table 3.3 we can select any bearing with bore more than or equal to 20mm

Table 3.3 [15]

Dimensions and Load Ratings for Ball Bearing

Dimensions and Load Ratings for Single-Row 02-Series Deep-Groove and Angular-Contact Ball Bearings									
Bore, mm	OD, mm	Width, mm	Fillet Radius, mm	Shoulder		Load Ratings, kN			
				Diameter, mm d_s	d_H	Deep Groove		Angular Contact	
						C_{10}	C_0	C_{10}	C_0
10	30	9	0.6	12.5	27	5.07	2.24	4.94	2.12
12	32	10	0.6	14.5	28	6.89	3.10	7.02	3.05
15	35	11	0.6	17.5	31	7.80	3.55	8.06	3.65
17	40	12	0.6	19.5	34	9.56	4.50	9.95	4.75
20	47	14	1.0	25	41	12.7	6.20	13.3	6.55
25	52	15	1.0	30	47	14.0	6.95	14.8	7.65
30	62	16	1.0	35	55	19.5	10.0	20.3	11.0
35	72	17	1.0	41	65	25.5	13.7	27.0	15.0
40	80	18	1.0	46	72	30.7	16.6	31.9	18.6



Figure 3.7
Deep-groove Ball Bearing

Also, we have selected a self-aligned thrust bearing on the bottom due to the radial and axial forces acting on the bearing. As for the thrust bearing, C_0 and C_{10} are found on SKF official website, which are 67 kN and 42.3 kN respectively based on bore diameter. [17]

Table 3.4

Dimensions and Load Rating “Thrust Bearings”

Principal dimensions				Basic load ratings		Fatigue load limit	Speed ratings		Designations	
d	D	H	H ₁	dynamic	static	P _U	Reference speed	Limiting speed	Bearing	Seat washer
mm				kN		kN	r/min			
▲	◆	◆	◆	◆	◆	◆	◆	◆	◆	◆
25	47	15		26.5	50	1.86	5300	7500	51205	
25	42	11		18.2	39	1.43	6300	9000	51105	
25	52	18		34.5	60	2.24	4500	6300	51305	

We chose FYH UCF205 for ball bearing and KOYO-51205 for thrust ball bearing.



Figure 3.8
Thrust bearing

3.2.5 Thrust Bearing Features

- **Accommodate static and dynamic misalignment**

The bearings are self-aligning like spherical roller bearings or CARB bearings.

- **Excellent high-speed performance**

Self-aligning ball bearings generate less friction than any other type of rolling bearing, which enables them to run cooler even at high speeds.

- **Minimum maintenance**

Due to low heat generation the bearing temperature is lower, leading to extended bearing life and maintenance intervals.

- **Low friction**

Very loose conformity between balls and outer ring keeps friction and frictional heat at low levels.

- **Excellent light load performance**

Self-aligning ball bearings have low minimum load requirements.

- **Low noise**

Self-aligning ball bearings can reduce noise and vibrations levels, for example, in fans.

3.3 Product Subsystems and Components

- Generator
- Energy: Gorlov Helical wind turbine
- Power: batteries may be used to store energy
- Break to stop the turbine in case we have too much wind velocity

3.3.1 Generator selection

Permanent magnet generator (That allows us to eliminate using gearbox), shown in figure 3.8



Figure 3.9
Generator

The generator we chose is the 12v model which is capable of more than 1 kW with sufficient wind speeds as shown in figure 3.9.

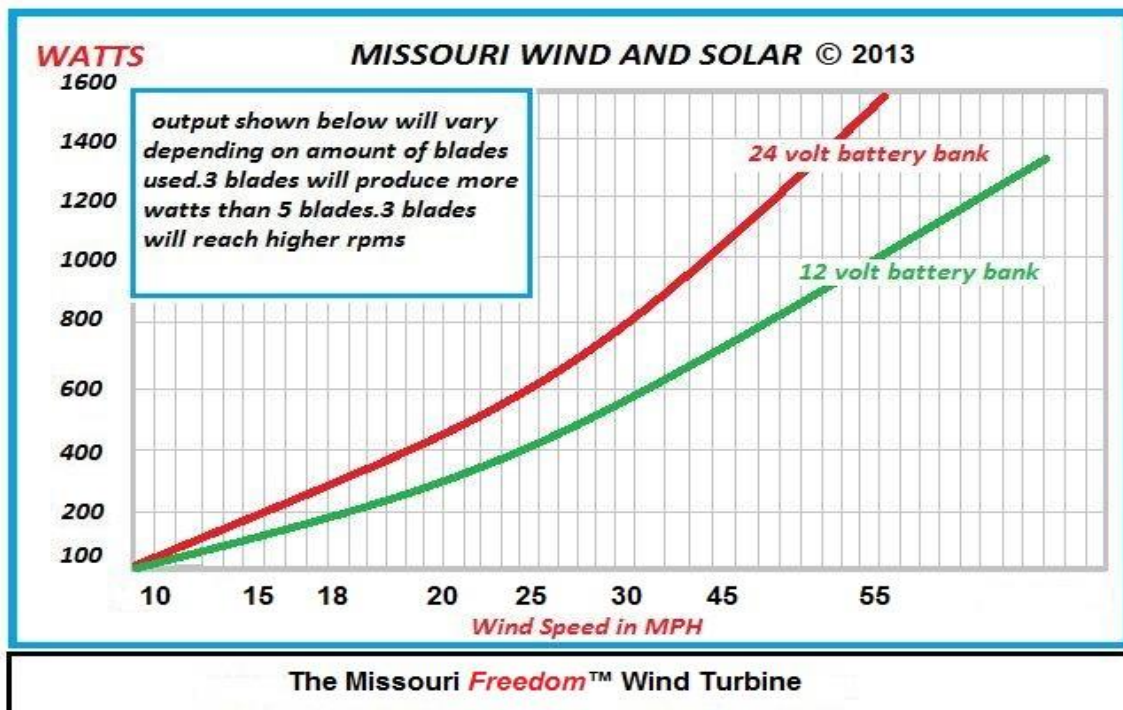

The wattages were derived at on a 65 foot wind turbine tower with no obstructions

Figure 3.10
Power at different wind speeds

3.3.1.1 PMG Features

- No cogging, easy to turn - Cut in speed of 6 MPH
- Skewed stator core with high grade electrical steel and heavy duty copper windings
- 17 mm stainless steel shaft compatible with all Missouri Wind and Solar hubs
- 2x thick polished aluminum case
- Zinc plated 14 rare earth neodymium magnet rotor
- No brushes to fail or replace
- Two heavy duty bearings in front and back
- Fits delco bolt patterns and mounts up to our standard mounting bracket

3.3.1.2 PMG Specifications

- 3/8" Diameter bolt holes
- 1 15/16" on center between mounting holes
- 7/8" OD Width
- 5/16" Tall

3.3.2 Brake design

The brake is applied manually by pressing the paddle shown in figure 3.12, which forces the brake housing shown in figure 3.13 which is linked to the shaft to get in contact with the black rubber ring which will absorb the energy via friction. The brake is held by the two yellow springs.

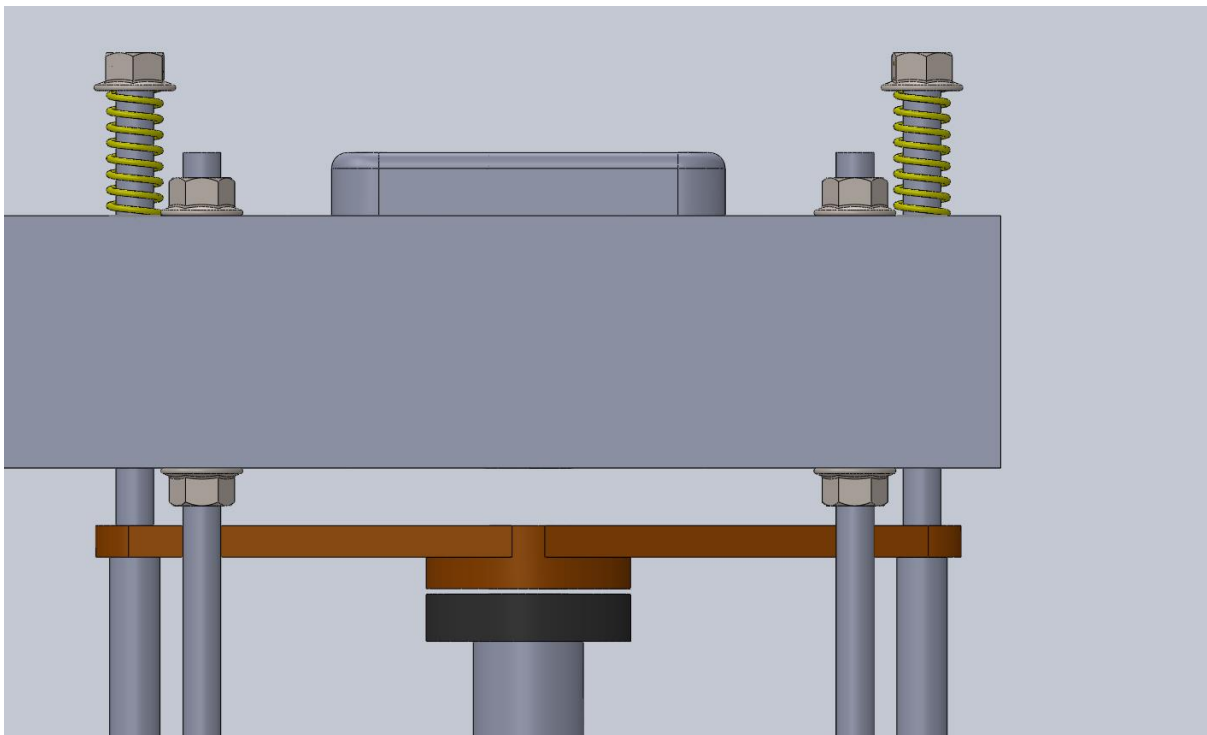

Figure 3.11
Braking mechanisms

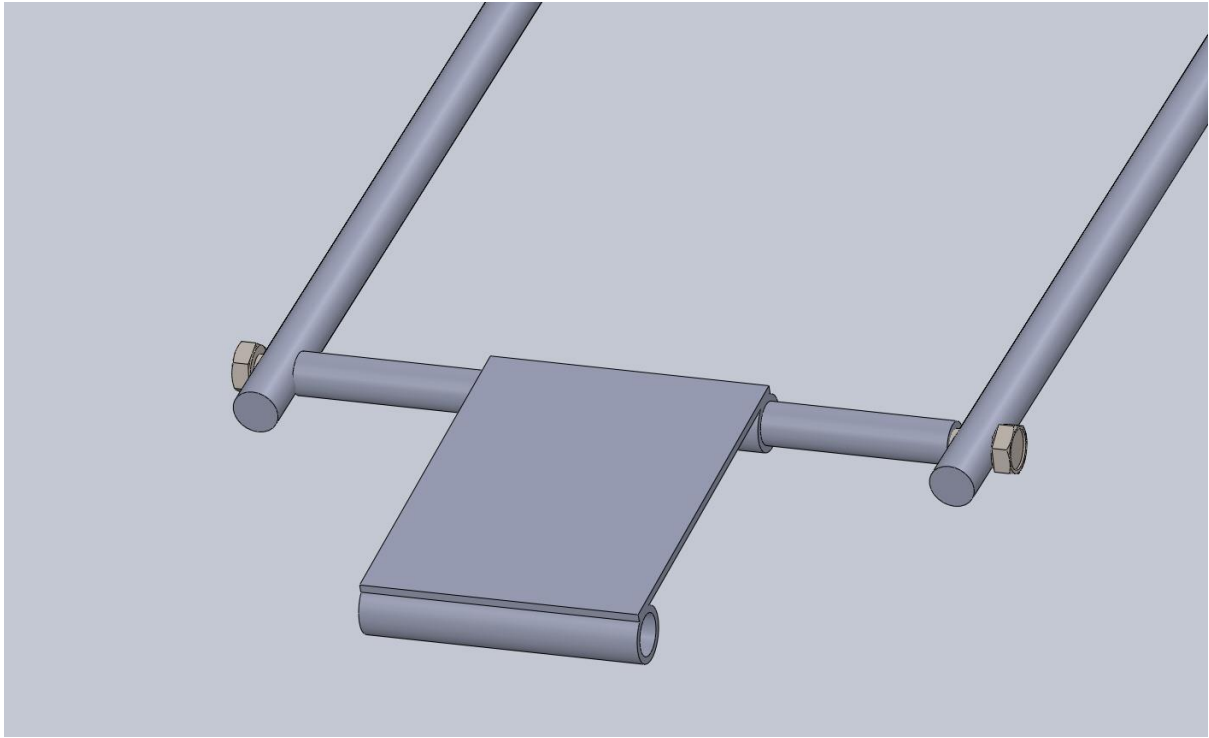

Figure 3.12
Braking Paddle

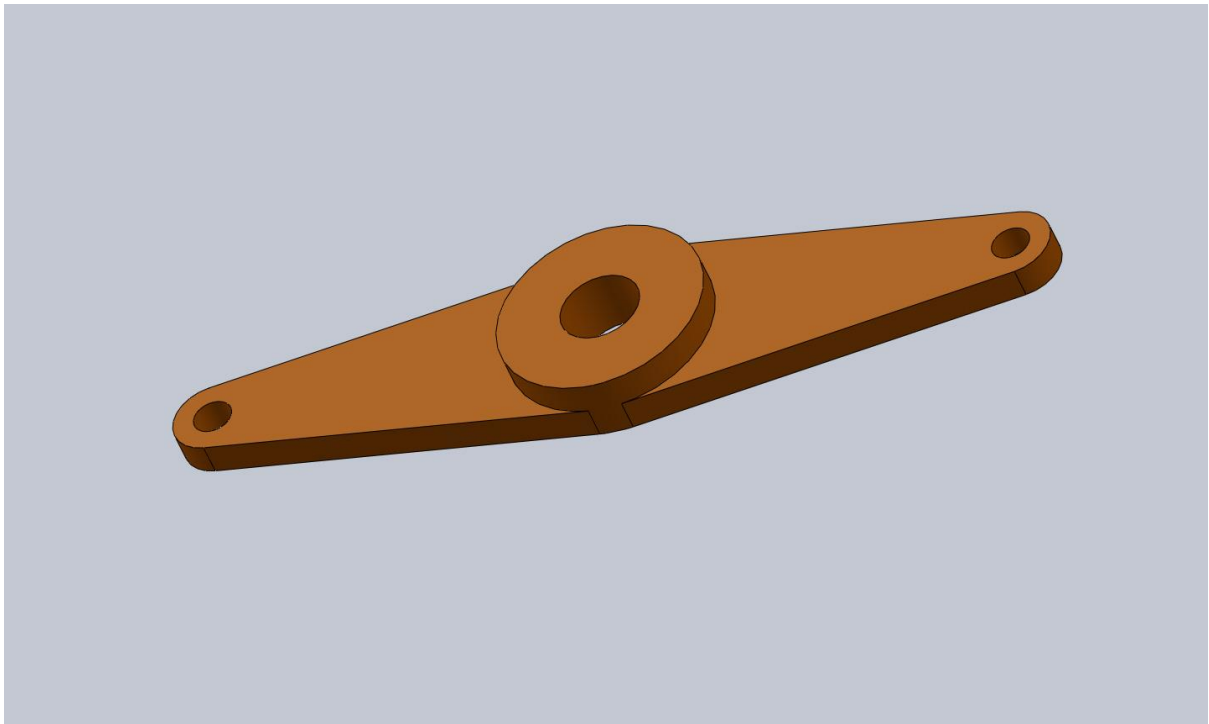

Figure 3.13
Brake Housing

3.4 Implementation

After our literature review, we found that Gorlov helical turbine is the most efficient and lightweight. In addition, it is capable of generating the needed amount of energy. The turbine consists of three blades that will be attached together using two blade supports top and bottom. These supports will be attached on a shaft that will be mounted on top of the permanent magnet generator. Finally, the whole system will be installed on top of the streetlight pole or will be attached on middle of the pole using two top and bottom supports.

3.5 Final Design Assembly (2D Drawing)

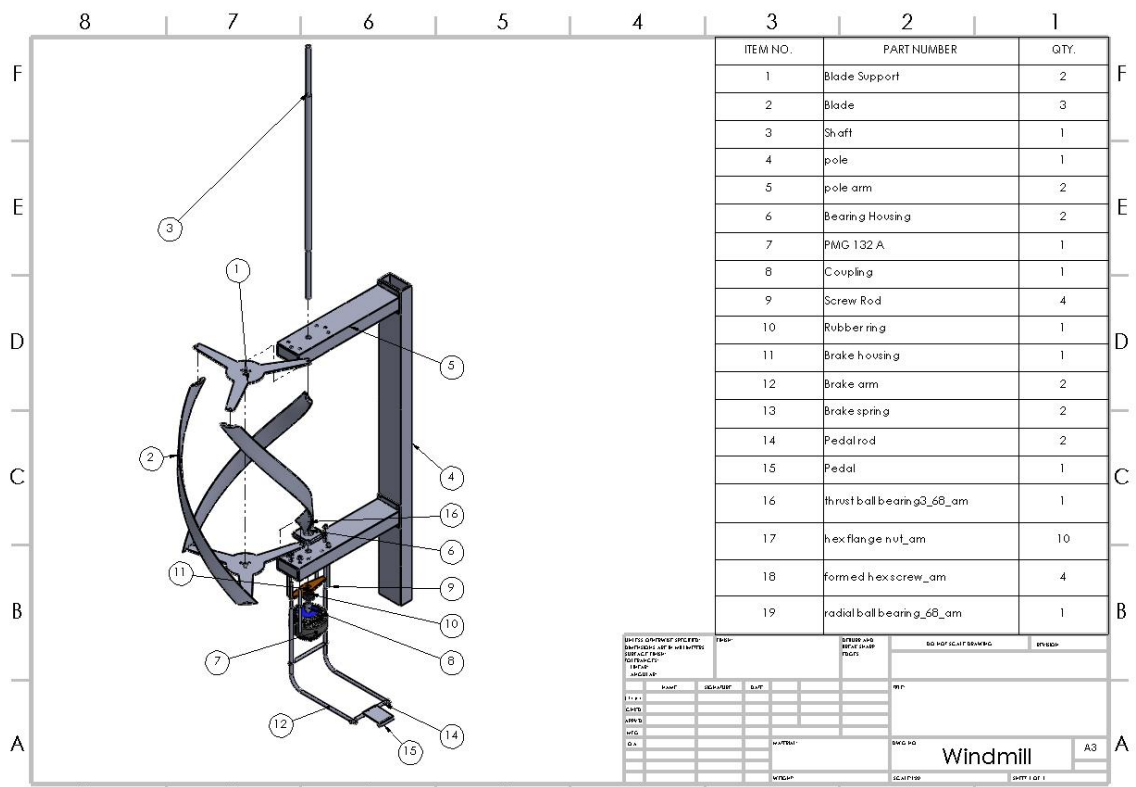

Figure 3.13
Assembly 2D Drawing

Chapter 4

System Testing and Analysis

4.1 Static Simulation

Using SolidWorks we were able to predict the static and dynamic behavior of the turbine by applying flow simulation the static was predicted by applying distributed force on the blades and the shaft as shown in figures 4.1 and 4.2 below:

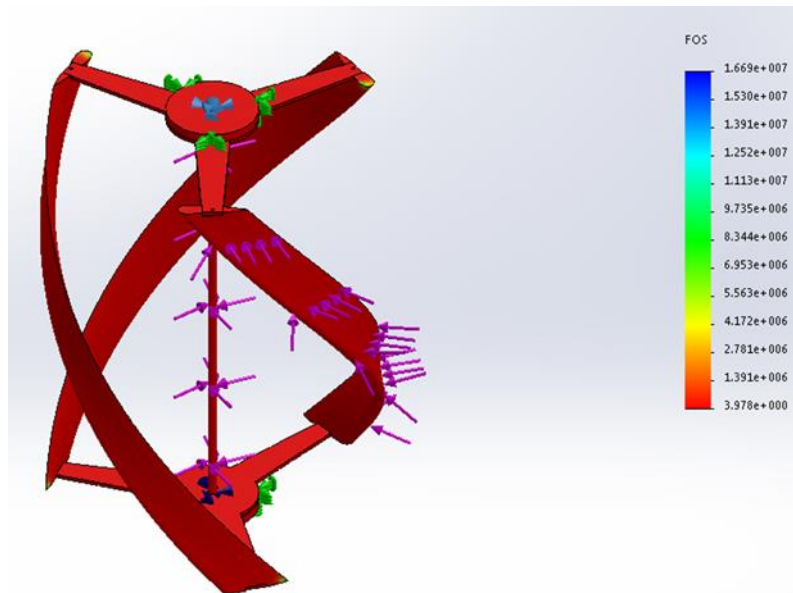

Figure 4.1
Static simulation 1

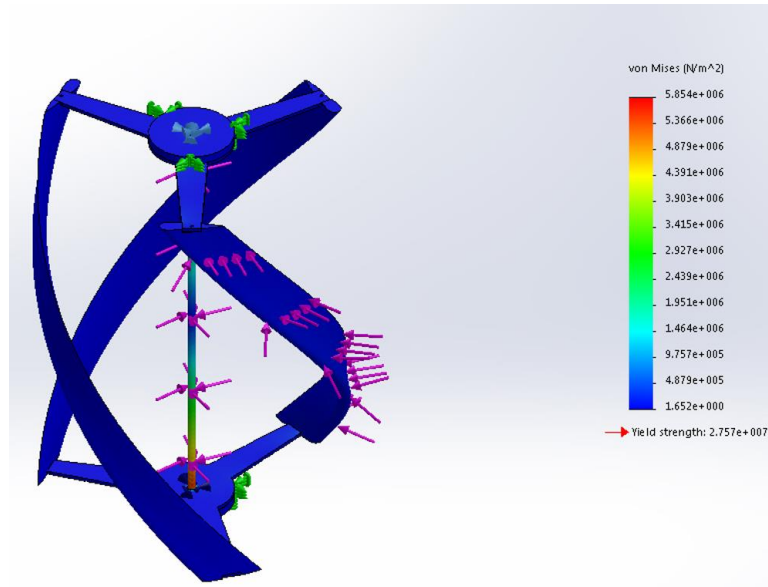

Figure 4.2
Static simulation 2

As shown in figures 4.1 and 4.2 the turbine is subjected to Von Mises stresses at the blades which are estimated to reach about 5.85 MPA and the factor of safety is at least to be equal to 4.

4.2 Dynamic simulation

The dynamic simulation was obtained via SolidWorks using the flow simulation, as shown in table 4.1 the frequency number and the rotational speed corresponding to it, note the zeroes are a result of the degrees of freedom being only one degree:

Table 4.1
Dynamic simulation

Frequency Number	Rad/sec	Hertz
1	0	0
2	92.211	14.676
3	92.227	14.678
4	131.82	20.979
5	174.97	27.847
6	292.55	46.56

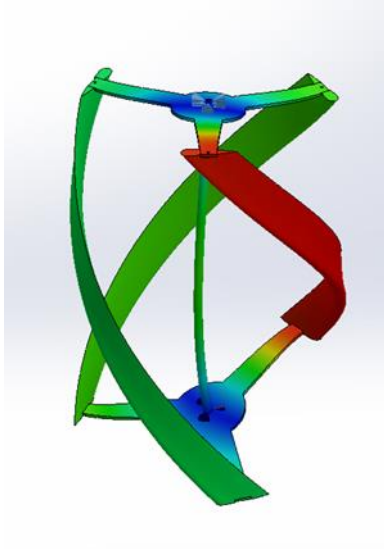

Figure 4.3
Behavior corresponding to frequency number 1

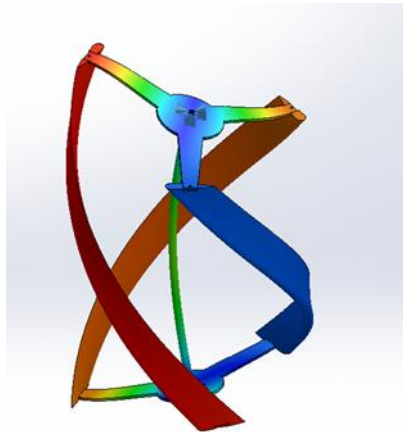

Figure 4.4
Behavior corresponding to frequency number 2

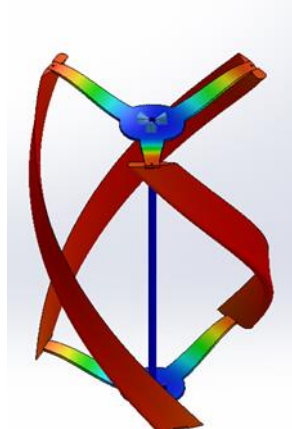

Figure 4.5
Behavior corresponding to frequency number 3

As shown in figure 4.5, the excitation will reach a critical point at 14.68 Hz at wind speed of 116 km/h which translates to 52 km/h once the tip speed ratio is factored in.

4.3 Testing

In this section we tested our turbine performance in the field, we used an anemometer to measure the wind speed and a tachometer to measure the rotational speed, and the results are shown in table 4.2 and figure 4.6

Table 4.2
Testing Results

Time		Wind Speed (m/s)	Rotational Speed (rpm)
Day 1	11 am	9.3	94
	2 pm	8.7	87
	10 pm	5.5	67
Day 2	11 am	4.1	52
	2 pm	3.6	44
	10 pm	2	26
Day 3	11 am	2.7	35
	2 pm	4.3	55
	10 pm	2.7	35

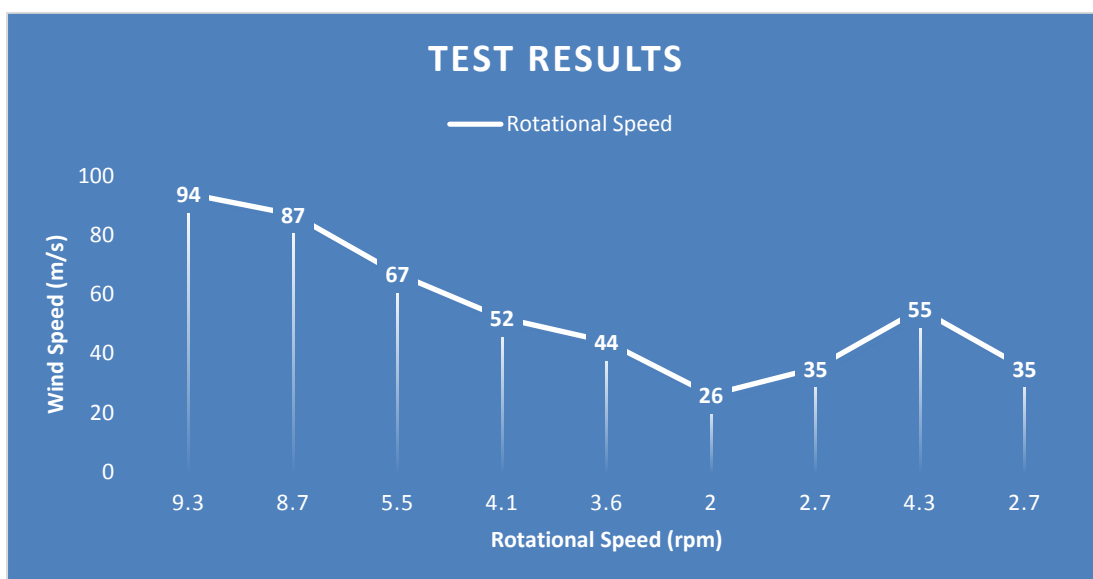

Figure 4.6
Test Results

Chapter 5

Project Management

5.1 Project Plan

The project was divided into seven stages; each stage has its own time limit that includes the beginning and the deadline. These stages are explained in table 5.1 below.

Table 5.1
Project Timeline

Activities	Feb	Mar	Apr	May
Identify study scope	Red			
Research proposal	Red			
Gathering project materials		Blue		
Hardware assembly and installation		Blue		
Writing project documentation			Brown	
Testing and analysis			Brown	
Presentation & demonstration of the project				Green

5.2 Contribution of Team Members

Each individual member was assigned a task to complete to finish off the goals in due time. Each goal was tackled by a different team member, while others did work on helping out certain members of the group who had a hard time completing some of the tasks. These are listed clearly within the course of table 5.2 that is shown below.

Each individual who had a hand in the completion of this project put in their maximum effort, and worked tirelessly to complete the tasks assigned to them. They were

able to complete each task allocated to them in due time, and were always available if others needed help completing what they needed help with.

The tasks were allocated as per table 5.2 below:

MAL: Mohammed Al-Sayid
 AHR: Ahmed Al-Ramadhan.
 AMN: Ameen Al-Naseer
 MBA: Mubarak Alwesmi
 MAM: Muath Al-Mansour

Table 5.2
 Work Distribution

Task	Team members
Introduction	AHR MBA
Literature Review	All
Designing Prototype	MAL AHR
Prototype Manufacturing	MAM MAL
Testing Prototype	All
Project Management & Distribution of Goals	MAM MAL
Analysis	AMN MAM
Conclusion and Implementations	MBA AHR

5.3 Project Execution Monitoring

Here are the activities that we completed throughout the semester in order to complete the project.

- 1) Planning stage.
- 2) Searching for different sources to learn about project.
- 3) Working on CAD to create a blueprint of the project.

- 4) Meeting weekly to ensure everyone is doing their part, and to discuss difficulties.
- 5) Meeting with our advisor for feedback and recommendations.
- 6) Manufacturing the prototype.
- 7) Maintaining the prototype and changing any parts that were obsolete.
- 8) Testing.
- 9) Completing final report.
- 10) Final presentation.

5.4 Challenges and Decision Making

- Workshop was difficult to find due to the complex of the design.
- Thrust bearing comes with no housing so we had to manufacture it.
- We could not find suitable generator in KSA, so we had to order it from out of kingdom.
- Team members have limited knowledge in aerodynamics.

5.5 Project Bill of Materials and Budget

The price for the individual parts that were used throughout the course of the project, as well as the amount bought for each of them is included in the table below. The BOM helps identify these parts and makes them easy to read.

Table 5.3
Bill of Materials (BOM)

<i>Parts</i>	<i>Quantity</i>	<i>Price Per Unit (in SAR)</i>	<i>Total Price (in SAR)</i>
<i>Blade Support</i>	<i>2</i>	<i>500</i>	<i>1000</i>
<i>Pole</i>	<i>1</i>	<i>500</i>	<i>500</i>
<i>Pole arm</i>	<i>2</i>	<i>250</i>	<i>500</i>
<i>Shaft</i>	<i>1</i>	<i>700</i>	<i>700</i>
<i>Blade</i>	<i>3</i>	<i>1,000</i>	<i>3,000</i>
<i>Ball Bearing</i>	<i>1</i>	<i>75</i>	<i>75</i>
<i>Thrust Bearing</i>	<i>1</i>	<i>25</i>	<i>25</i>
<i>Housing for Bearing</i>	<i>1</i>	<i>200</i>	<i>200</i>
<i>Generator</i>	<i>1</i>	<i>2,000</i>	<i>2,000</i>
<i>Total Price</i>	<i>8,000</i>		

The budget is broken down more effectively to show the remaining aspects of the project that were not mentioned in the previous table, elaborating on the materials used on the project. It deals with the cost of the various other funds that were spent throughout the course of this project.

Table 5.4
Project budget breakdowns

<i>Item</i>	<i>Cost (in SAR)</i>
<i>Material</i>	<i>3,000</i>
<i>Final Report Draft (x2)</i>	<i>105</i>
<i>Final Report (x3 leather book)</i>	<i>750</i>
<i>Poster and Brochures</i>	<i>280</i>
<i>Total</i>	<i>4,135</i>
<i>Grand Total of the Project</i>	<i>12,135</i>

Chapter 6

Project Analysis

6.1 Life-long Learning

Since our first encounter with the Prince Mohammad Bin Fahd University, they were consistently elaborating heavily on the core competencies of the university and how we must learn them heavily; this was reinstated heavily during the course of this project. Many of the competencies the university spent so much time teaching us were needed in order to complete this project, such as the ability to think critically, as well as the ability to work well with the team. We managed to get through the challenges of this project through working thoroughly with these competencies, and accomplishing the many goals we had set for each other.

While working on our project, we have used various tools such as:

- Solid Work (CAD)
- Excel
- Google Drive

We have also learned how to use various testing tools to test on the wind turbine, these tools include:

a) Anemometer

Which is a device used to measure the wind speed, shown in figure 6.1



Figure 6.1
Anemometer

b) Tachometer

The device we used to measure the rotational speed of the turbine, as shown in figure 6.2



Figure 6.2
Tachometer

c) Voltmeter

The device used to measure the voltage and the current, as shown in figure 6.3

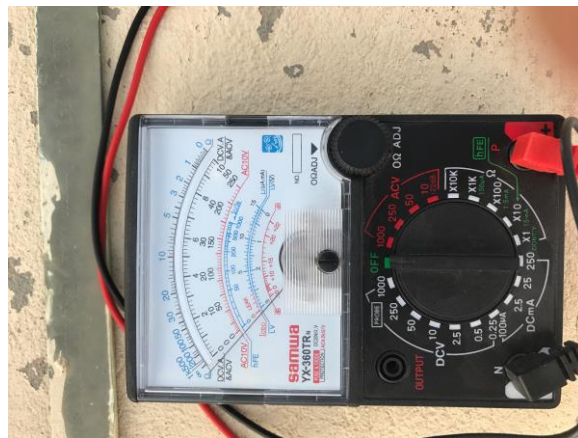

Figure 6.3
Voltmeter

6.2 Impact of Engineering Solutions

As with all energy supply options, wind energy development can have adverse environmental and economic impacts, where both can result in social impact. Harnessing power from the wind is one of the cleanest and most sustainable ways to generate electricity as it produces no toxic pollution or global warming emissions. Wind is also abundant, inexhaustible, and affordable, which makes it a viable and large-scale alternative to fossil fuels. Wind energy costs are now lower than the costs of most new conventional sources and are close to cost-competitive with new natural gas generation due to continuing technological innovation. Building and maintaining wind turbines costs money but no one pays for the wind itself. Since wind is a free fuel, wind power prices do not go through the kind of price fluctuations consumers experience with fossil fuels.

The main design of the helical wind turbine helps in the sense that it can be added to many different buildings in urbanized areas, where more conventional wind turbines that include blades may be considered a risk to safety. Their need for little wind to operate effectively

further increases their importance in these areas, as many people can begin determining on them rather than focusing on the more conventional approach. The design drastically helps bring wind generated power to the urbanized city locations, especially on top of skyscrapers, buildings, apartment complexes and houses.

6.3 Contemporary Issues Addressed

Because of the abundance of oil in the GCC especially in the Kingdom Saudi Arabia, we have become heavily dependent on oil in many fields, chief among of which is power generation, as a result, nearly all the power in the Kingdom of Saudi Arabia is produced through oil and gas, and as the grim reality of oil being drained sinks in, Saudi Arabia have to seek other means of energy production, this is especially hard considering how much Saudi depends on fossil fuels. This shift towards renewable energy will generate resistance towards it from the oil industry as it will lessen the dependence on fossil fuels, but with the 2030 vision towards the usage of renewable energy, the shift will be inevitable.

After the oil crisis that hit the Kingdom of Saudi Arabia recently, the reality of oil not lasting forever has become apparent, this made it even more necessary for the country to diversify their source of energy. Through investment in the wind energy, the country would begin pouring its investments in a safe and reliable energy source. This energy source can easily be implemented in the new boom of buildings that are being built recently. The country's vision to expand the country would be achieved much more effectively through becoming contenders in the world's race to providing newer sources of energy. Through the continued research and development within this, it can be implemented and tested thoroughly, allowing for more jobs to be created for the matter, and further reducing the price

of power that people use. The rise in electric and oil bills will not affect the citizens as severely because of the new manner in which energy will be provided. The countries focus on this will also lead to many other businesses being created investing in said turbines, allowing for further development in their creations, and to overall improve the global research that is going into supplying the world with new, renewable clean energy.

Chapter 7

Conclusions and Future Recommendations

7.1 Conclusions

Through numerous testing and careful analysis of the vertical wind turbine, we managed to draw up various conclusions on their effectiveness, and their general importance in the development of clean energy within the Kingdom of Saudi Arabia. Through careful testing, we compared the different aspects of the vertical turbine with the horizontal, and drew up the following conclusions.

One of the important aspects of the vertical turbine is that it does not need to be indicated towards the wind for it to work powerfully. This makes it effective within a territory with shifting wind course. Also, it is equipped for working amid insignificant wind speed, this is because of its long curved propellers are intended to be pushed by a little measure of wind. Further testing has also proven that it does not need to introduce at a high place. Effectively obvious to natural life, while turning or very still. When compared to the other turbines, horizontal, we notice that pros of the vertical outweigh that of the horizontal.

7.2 Future Recommendations

Certain recommendations are to be made after the completion of the project in order to receive better results, and more effective outcomes. The first recommendation is to buy from manufacturers around the country rather than from foreign countries. We experienced difficulties sourcing the generator that we purchased online because there we no company we found that manufactures or imports generators with our specifications, thus we ordered our

generator from outside of Saudi. Also another problem we experienced was with our limited data output. One of the tests that were to be conducted was to see how the turbine worked with different wind speeds. However because of the time of year, it was almost always windy, which made it difficult to find times of day in which the wind would settle to test how the turbine would work under minimum wind conditions. This led to fluctuations in the results, and therefore gave a larger margin of error.

The material used could have also dramatically changed the outcome of the project. Certain materials such as fiber glass were difficult to come by, finding these different materials would have made designing the project more realistic, and more resembling of an actual turbine that could be used within an urban environment. The fiber glass option would be more effective for our design. Also the design could make use of thinner blades to reduce the weight as the profile could handle the wind load with significant safety factor.

Moreover, we found out that the braking mechanism needs more machining as it slows down the rotation of the turbine without application.

References

1. History of wind turbines. (November 21, Renewable Energy World, 2014). From: www.renewableenergyworld.com/ugc/articles/2014/11/history-of-wind-turbines
2. AWEA (2013). Wind 101: the basics of wind energy.
3. Price, Trevor J (3 May 2005). "James Blyth - Britain's First Modern Wind Power Engineer". *Wind Engineering*. 29 (3): 191–200.
4. Alajmi, Jelowi, Alsayed & Tareq (2014) Design of Airfoils for Wind Turbine Rotors. American University, Sharqa, UAE
5. Casini, M., (2016). Small vertical axis wind turbines for energy efficiency of buildings. *JOCE Vol. 14/254*
6. Rishmany, Daaboul, Tawk† & Saba (2017). Optimization of a Vertical Axis Wind Turbine Using FEA, Multibody Dynamics and Wind Tunnel Testing. *Athens Journal of Technology and Engineering X Y 1*
7. Khan, Moniruzzaman, Feroz & Islam (2012). Design ,fabrication & analysis of a helical vertical wind turbine. Undergraduate Student (Mechanical), CUET,
8. Al Khobar, Ash Sharqiyah 14 Day Weather Forecast, Saudi Arabia <https://www.worldweatheronline.com/al-khobar-weather/ash-sharqiyah/sa.aspx>
9. Weigel, R., Spichtinger, P., Mahnke, C., Klingebiel, M., Afchine, A., Petzold, A., ... & Szakáll, M. (2016). Thermodynamic correction of particle concentrations measured by underwing probes on fast-flying aircraft. *Atmospheric Measurement Techniques*, 9(10), 5135. [2]
10. Bergey, K. H. (1979). The Lanchester-Betz limit (energy conversion efficiency factor for windmills). *Journal of Energy*, 3(6), 382-384.

11. Mitsuhiro Shiono, Katsuyuki Suzuki, and Seiji Kiho. Output characteristics of Darrieus water turbine with helical blades for tidal current generations. In Proceedings of The Twelfth (2002) International Offshore and Polar Engineering Conference, 2002.
12. Battisti, L., Brighenti, A., Benini, E., & Castelli, M. R. (2016, September). Analysis of Different Blade Architectures on small VAWT Performance. In *Journal of Physics: Conference Series* (Vol. 753, No. 6, p. 062009). IOP Publishing.
13. Dyrbye, C., & Hansen, S. O. (1996). Wind loads on structures.
14. Wind Velocity and Wind Load : http://www.engineeringtoolbox.com/wind-load-d_1775.html
15. Shigley, J. E., Mischke, C. R., & Budynas, R. G. (2004). Mechanical engineering design. McGraw-Hill,.
16. Ellis, D. E. (1960). MECHANICAL PROPERTIES OF ALUMINUM ALLOYS AT VARIOUS TEMPERATURES (No. NAA-SR-Memo-5716). Atomics International. Div. of North American Aviation, Inc., Canoga Park, Calif.
17. <http://www.skf.com/group/products/bearings-units-housings/ball-bearings/thrust-ball-bearings/single-direction/index.html>

Appendix A: Datasheets



Simulation of Windmill Dynamic - 2

Date: Sunday, May 28, 2017
Designer: Solidworks
Study name: Dynamic Analysis
Analysis type: Linear dynamic analysis (Modal Time History)

Table of Contents

Description	67
Assumptions	68
Model Information	69
Study Properties	71
Units	72
Material Properties	72
Loads and Fixtures	73
Connector Definitions	73
Contact Information	74
Mesh information	75
Study Results	76

1 Description

No Data

2 Assumptions



None

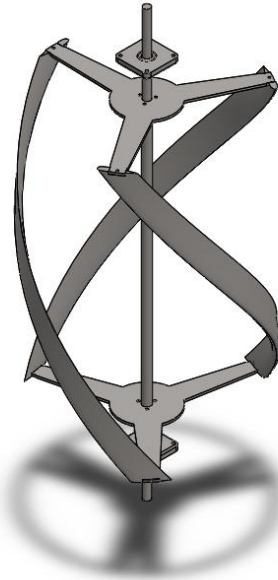



3 Model Information





Model name: Windmill Dynamic - 2
Current Configuration: Default

Solid Bodies

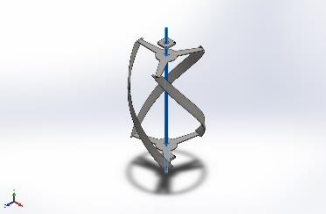
Document Name and Reference	Treated As	Volumetric Properties	Document Path/Date Modified
<p>Cut-Extrude1</p> 	Solid Body	<p>Mass:2.02961 kg Volume:0.000260207 m³ Density:7800 kg/m³ Weight:19.8902 N</p>	<p>C:\Users\MSI\Dropbox\Windmill\Muath\Bearing Housing.SLDPRT May 20 19:09:15 2017</p>
<p>Cut-Extrude1</p> 	Solid Body	<p>Mass:2.02961 kg Volume:0.000260207 m³ Density:7800 kg/m³ Weight:19.8902 N</p>	<p>C:\Users\MSI\Dropbox\Windmill\Muath\Bearing Housing.SLDPRT May 20 19:09:15 2017</p>

<p>Cut-Extrude4</p> 	<p>Solid Body</p>	<p>Mass:4.74692 kg Volume:0.00060858 m³ Density:7800 kg/m³ Weight:46.5199 N</p>	<p>C:\Users\MSI\Dropbox\Windmill\Muath\Blade Support.SLDPRT May 24 12:27:24 2017</p>
<p>Cut-Extrude4</p> 	<p>Solid Body</p>	<p>Mass:4.74692 kg Volume:0.00060858 m³ Density:7800 kg/m³ Weight:46.5199 N</p>	<p>C:\Users\MSI\Dropbox\Windmill\Muath\Blade Support.SLDPRT May 24 12:27:24 2017</p>
<p>Cut-Extrude4</p> 	<p>Solid Body</p>	<p>Mass:11.918 kg Volume:0.001528 m³ Density:7799.74 kg/m³ Weight:116.796 N</p>	<p>C:\Users\MSI\Dropbox\Windmill\Muath\Blade.SLDPRT T Apr 19 11:48:50 2017</p>
<p>Cut-Extrude4</p> 	<p>Solid Body</p>	<p>Mass:11.9197 kg Volume:0.001528 m³ Density:7800.83 kg/m³ Weight:116.813 N</p>	<p>C:\Users\MSI\Dropbox\Windmill\Muath\Blade.SLDPRT T Apr 19 11:48:50 2017</p>
<p>Cut-Extrude4</p> 	<p>Solid Body</p>	<p>Mass:11.9195 kg Volume:0.001528 m³ Density:7800.71 kg/m³ Weight:116.811 N</p>	<p>C:\Users\MSI\Dropbox\Windmill\Muath\Blade.SLDPRT T Apr 19 11:48:50 2017</p>
<p>Mirror1</p> 	<p>Solid Body</p>	<p>Mass:7.78383 kg Volume:0.000997927 m³ Density:7800 kg/m³ Weight:76.2815 N</p>	<p>C:\Users\MSI\Dropbox\Windmill\Muath\Shaft.SLDPRT May 27 12:13:37 2017</p>

<p>OuterRace</p> 	<p>Solid Body</p>	<p>Mass:0.174704 kg Volume:2.23979e-005 m³ Density:7800 kg/m³ Weight:1.7121 N</p>	<p>c:\solidworks data\browser\ansi metric\bearings\ball bearings\radial ball bearing_68_am.sldprt May 24 13:26:44 2017</p>
<p>Fillet</p> 	<p>Solid Body</p>	<p>Mass:0.19085 kg Volume:2.44679e-005 m³ Density:7800 kg/m³ Weight:1.87033 N</p>	<p>c:\solidworks data\browser\ansi metric\bearings\ball bearings\thrust ball bearing3_68_am.sldprt May 20 19:07:39 2017</p>

4 Study Properties

Study name	Dynamic Analysis
Analysis type	Linear dynamic analysis (Modal Time History)
Mesh type	Solid Mesh
Number of frequencies	15
Solver type	FFEPlus
Soft Spring:	Off
Incompatible bonding options	Automatic
Thermal option	Include temperature loads
Zero strain temperature	298 Kelvin
Include fluid pressure effects from SOLIDWORKS Flow Simulation	Off
Start time	0 Seconds
End time	10 Seconds
Time increment	0.2 Seconds
Dead Load Effects	Off
Result folder	SOLIDWORKS document (C:\Users\MSI\Dropbox\Windmill\Muath)

5 Units

Unit system:	SI (MKS)
Length/Displacement	mm
Temperature	Kelvin
Angular velocity	Rad/sec
Pressure/Stress	N/m ²

6 Material Properties

Model Reference	Properties	Components
	<p>Name: Plain Carbon Steel</p> <p>Model type: Linear Elastic Isotropic</p> <p>Default failure criterion: Max von Mises Stress</p> <p>Yield strength: 2.20594e+008 N/m²</p> <p>Tensile strength: 3.99826e+008 N/m²</p> <p>Elastic modulus: 2.1e+011 N/m²</p> <p>Poisson's ratio: 0.28</p> <p>Mass density: 7800 kg/m³</p> <p>Shear modulus: 7.9e+010 N/m²</p> <p>Thermal expansion coefficient: 1.3e-005 /Kelvin</p>	<p>SolidBody 1(Cut-Extrude1)(Bearing Housing-1), SolidBody 1(Cut-Extrude1)(Bearing Housing-2), SolidBody 1(Cut-Extrude4)(Blade Support-1), SolidBody 1(Cut-Extrude4)(Blade Support-2), SolidBody 1(Cut-Extrude4)(Blade-1), SolidBody 1(Cut-Extrude4)(Blade-2), SolidBody 1(Cut-Extrude4)(Blade-3), SolidBody 1(Mirror1)(Shaft-1), SolidBody 1(OuterRace)(radial ball bearing_68_am-1), SolidBody 1(Fillet)(thrust ball bearing3_68_am-1)</p>
Curve Data:N/A		

7 Loads and Fixtures

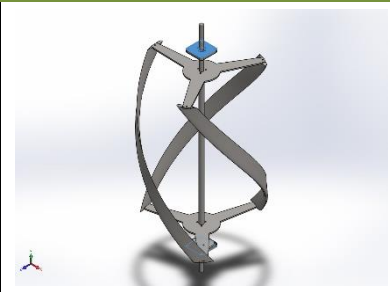
Fixture name	Fixture Image	Fixture Details		
Fixed-1		Entities: 2 face(s) Type: Fixed Geometry		
Resultant Forces				
Components	X	Y	Z	Resultant
Reaction force(N)	-0.00872281	6.64927	170.961	171.09
Reaction Moment(N.m)	0	0	0	0

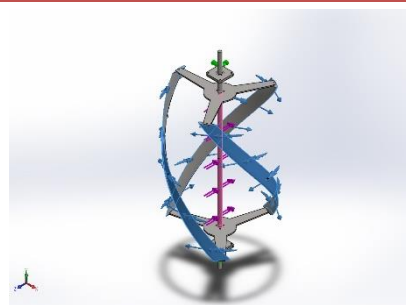
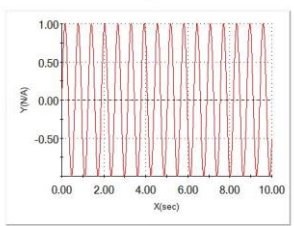
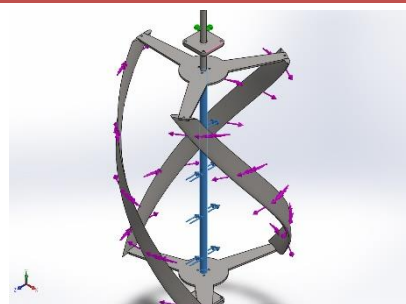
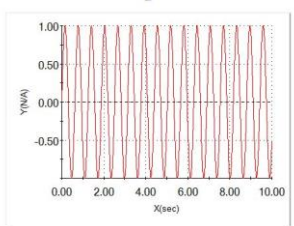
Load name	Load Image	Load Details	Function Curve
Torque-1		Entities: 3 face(s) Reference: Face< 1 > Type: Apply torque Value: 45 N.m	 1
Force-1		Entities: 1 face(s) Reference: Edge< 1 > Type: Apply force Values: ---, ---, -150 N	 2

8 Connector Definitions

No Data

9 Contact Information

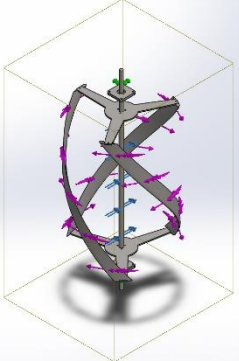
Contact	Contact Image	Contact Properties
Global Contact	 A 3D CAD model of a mechanical component, possibly a bracket or a support, is shown within a wireframe bounding box. The model is rendered in a light gray color. Several purple arrows point to specific locations on the model, indicating contact points. A small green crosshair is visible at the top of the model. The model is set against a light blue background with a subtle gradient.	Type: Bonded Components: 1 component(s) Options: Compatible mesh

10 Mesh information

Mesh type	Solid Mesh
Mesher Used:	Curvature based mesh
Jacobian points	4 Points
Maximum element size	20 mm
Minimum element size	4 mm
Mesh Quality	Draft Quality Mesh
Remesh failed parts with incompatible mesh	On

Mesh information - Details

Total Nodes	19332
Total Elements	68072
Maximum Aspect Ratio	19.054
% of elements with Aspect Ratio < 3	94.1
% of elements with Aspect Ratio > 10	0.0676
Time to complete mesh(hh:mm:ss):	00:00:06
Computer name:	LEOPARD

Model name: Windmill Dynamic - 2
Study name: Dynamic Analysis (-Default-)
Mesh type: Solid Mesh

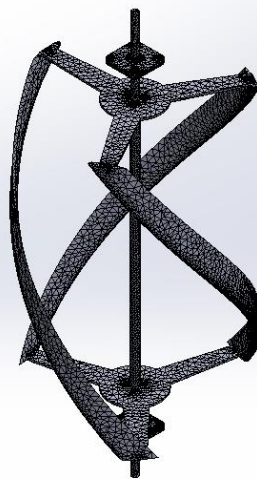

11 Study Results

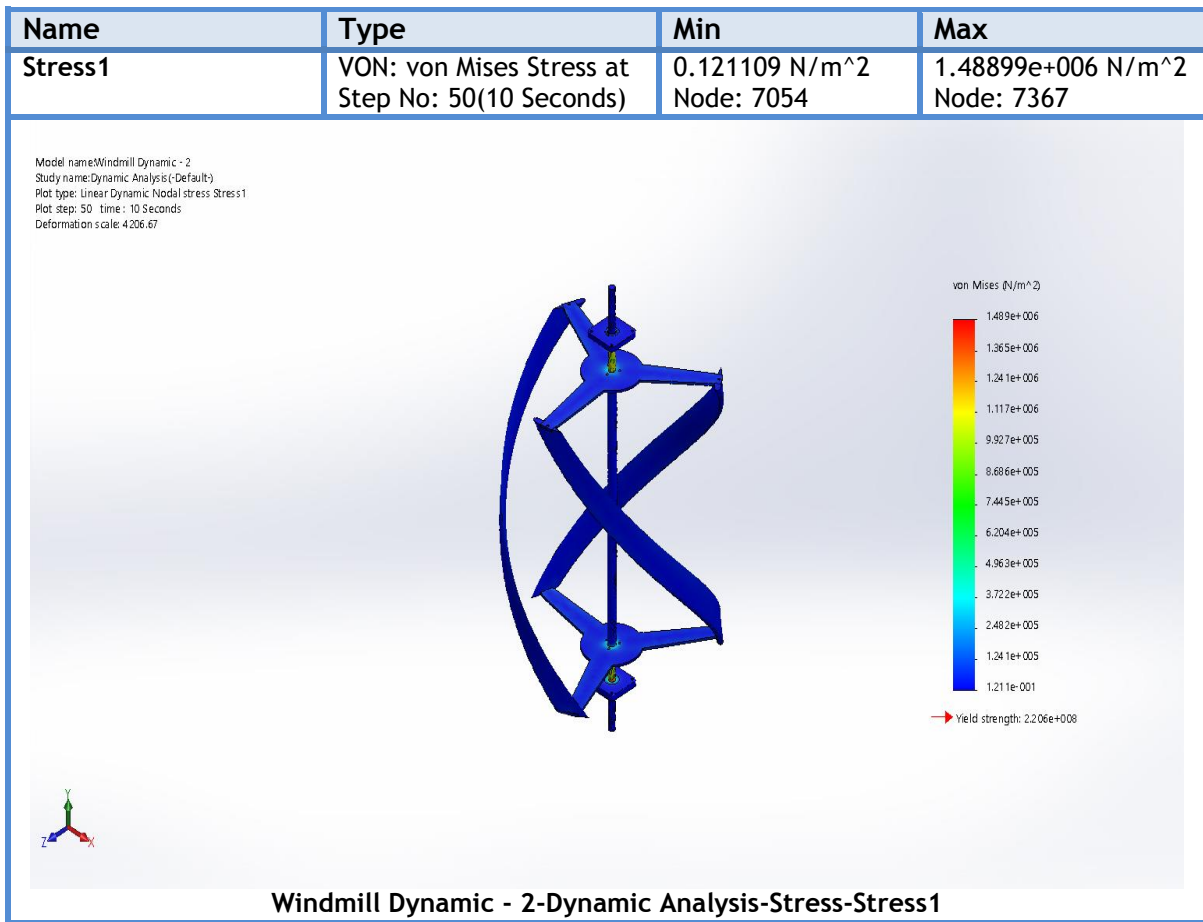

Name	Type	Min	Max
Displacement1	URES: Resultant Displacement at Step No: 50(10 Seconds)	0 mm Node: 17	0.0382276 mm Node: 12024

Model name: Windmill Dynamic - 2
 Study name: Dynamic Analysis (-Default)
 Plot type: Linear Dynamic Displacement Displacement1
 Plot step: 50 time : 10 Seconds
 Deformation scale: 4206.67

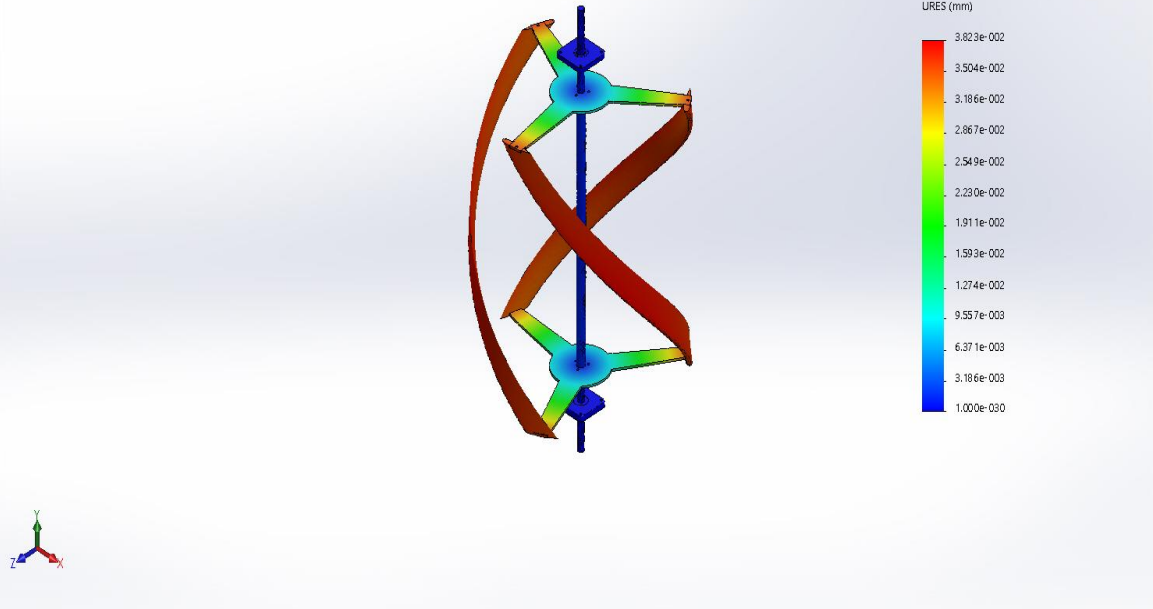

Windmill Dynamic - 2-Dynamic Analysis-Displacement-Displacement1

Name	Type
Frequency Response Graph1	Frequency Response

Frequency vs.Mode No.

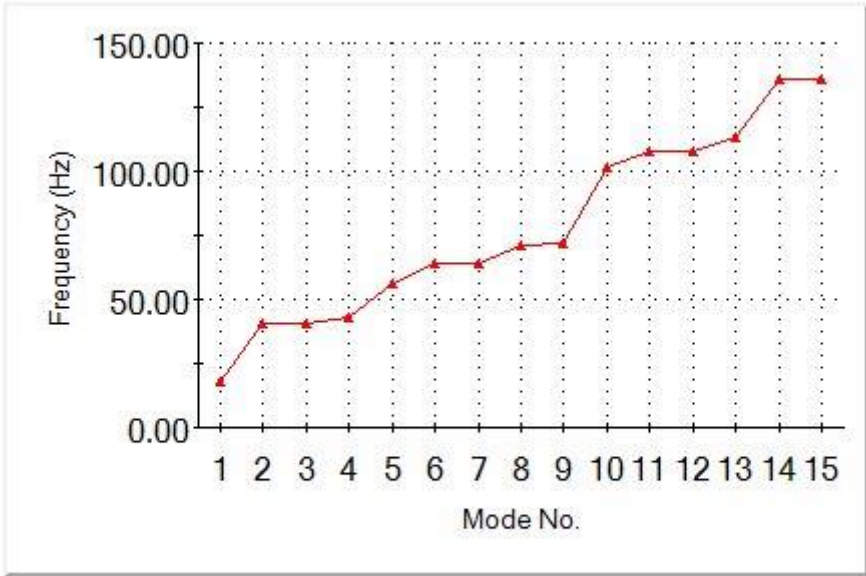

—▲— Natural Frequency

0,0

Windmill Dynamic - 2-Dynamic Analysis-Frequency Response Graph-Frequency Response Graph1

Mass Participation (Normalized)

Mode Number	Frequency(Hertz)	X direction	Y direction	Z direction
1	18.023	4.3939e-009	8.4911e-005	1.7744e-013
2	40.863	0.094494	8.6899e-005	0.0023521
3	40.993	0.0026504	4.2144e-005	0.097604
4	42.641	6.0653e-005	0.00043101	0.00025372
5	56.329	0.0010342	0.67884	6.756e-005
6	63.814	0.014361	4.441e-005	0.56078
7	63.9	0.56103	0.00074321	0.014282
8	71.279	0.00068617	6.9334e-005	0.026784
9	71.53	0.030514	0.00026286	0.00077743
10	101.9	5.3758e-007	5.8567e-005	1.0192e-005
11	107.7	0.021251	1.4884e-005	0.015122
12	107.86	0.01424	4.742e-007	0.021227
13	113.14	3.2208e-006	0.0046951	6.673e-006
14	135.6	0.00013756	4.5687e-007	0.0041066
15	136.03	0.0036333	2.1377e-006	9.6532e-005
		Sum X = 0.7441	Sum Y = 0.68538	Sum Z = 0.74347



Simulation of Windmill Static

Date: Saturday, May 27, 2017
Designer: Solidworks
Study name: Static Analysis
Analysis type: Static

Table of Contents

Description	80
Assumptions	81
Model Information	82
Study Properties	84
Units	84
Material Properties	85
Loads and Fixtures	86
Connector Definitions	86
Contact Information	87
Mesh information	88
Sensor Details	89
Resultant Forces	89
Study Results	90

12 Description

No Data

13 Assumptions



None

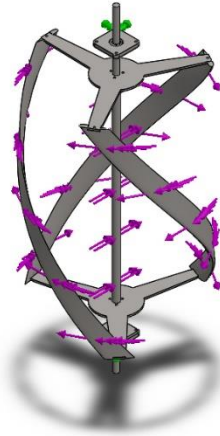





14 Model Information

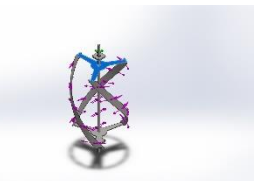

Model name: Windmill Static
Current Configuration: Default

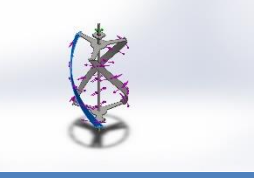
Solid Bodies

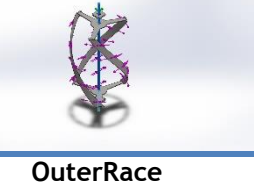
Document Name and Reference	Treated As	Volumetric Properties	Document Path/Date Modified
Cut-Extrude1 	Solid Body	Mass:2.02961 kg Volume:0.000260207 m ³ Density:7800 kg/m ³ Weight:19.8902 N	C:\Users\MSI\Dropbox\Windmill\Muath\Bearing Housing.SLDPRT May 20 19:09:15 2017
Cut-Extrude1 	Solid Body	Mass:2.02961 kg Volume:0.000260207 m ³ Density:7800 kg/m ³ Weight:19.8902 N	C:\Users\MSI\Dropbox\Windmill\Muath\Bearing Housing.SLDPRT May 20 19:09:15 2017
Cut-Extrude4 	Solid Body	Mass:4.74692 kg Volume:0.00060858 m ³ Density:7800 kg/m ³ Weight:46.5199 N	C:\Users\MSI\Dropbox\Windmill\Muath\Blade Support.SLDPRT May 24 12:27:24 2017

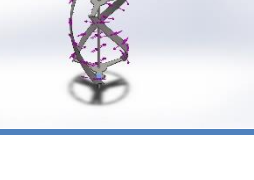
<p>Cut-Extrude4</p> 	<p>Solid Body</p>	<p>Mass:4.74692 kg Volume:0.00060858 m³ Density:7800 kg/m³ Weight:46.5199 N</p>	<p>C:\Users\MSI\Dropbox\Windmill\Muath\Blade Support.SLDPRT May 24 12:27:24 2017</p>
<p>Cut-Extrude4</p> 	<p>Solid Body</p>	<p>Mass:11.918 kg Volume:0.001528 m³ Density:7799.74 kg/m³ Weight:116.796 N</p>	<p>C:\Users\MSI\Dropbox\Windmill\Muath\Blade.SLDPRT Apr 19 11:48:50 2017</p>
<p>Cut-Extrude4</p> 	<p>Solid Body</p>	<p>Mass:11.9197 kg Volume:0.001528 m³ Density:7800.83 kg/m³ Weight:116.813 N</p>	<p>C:\Users\MSI\Dropbox\Windmill\Muath\Blade.SLDPRT Apr 19 11:48:50 2017</p>
<p>Cut-Extrude4</p> 	<p>Solid Body</p>	<p>Mass:11.9195 kg Volume:0.001528 m³ Density:7800.71 kg/m³ Weight:116.811 N</p>	<p>C:\Users\MSI\Dropbox\Windmill\Muath\Blade.SLDPRT Apr 19 11:48:50 2017</p>
<p>Mirror1</p> 	<p>Solid Body</p>	<p>Mass:7.78383 kg Volume:0.000997927 m³ Density:7800 kg/m³ Weight:76.2815 N</p>	<p>C:\Users\MSI\Dropbox\Windmill\Muath\Shaft.SLDPRT May 27 12:13:37 2017</p>
<p>OuterRace</p> 	<p>Solid Body</p>	<p>Mass:0.174704 kg Volume:2.23979e-005 m³ Density:7800 kg/m³ Weight:1.7121 N</p>	<p>c:\solidworks data\browser\ansi metric\bearings\ball bearings\radial ball bearing_68_am.sldprt May 24 13:26:44 2017</p>
<p>Fillet</p> 	<p>Solid Body</p>	<p>Mass:0.19085 kg Volume:2.44679e-005 m³ Density:7800 kg/m³ Weight:1.87033 N</p>	<p>c:\solidworks data\browser\ansi metric\bearings\ball bearings\thrust ball bearing3_68_am.sldprt May 20 19:07:39 2017</p>

15 Study Properties

Study name	Static Analysis
Analysis type	Static
Mesh type	Solid Mesh
Thermal Effect:	On
Thermal option	Include temperature loads
Zero strain temperature	298 Kelvin
Include fluid pressure effects from SOLIDWORKS Flow Simulation	Off
Solver type	FFEPlus
Inplane Effect:	Off
Soft Spring:	Off
Inertial Relief:	Off
Incompatible bonding options	Automatic
Large displacement	Off
Compute free body forces	On
Friction	Off
Use Adaptive Method:	Off
Result folder	SOLIDWORKS document (C:\Users\MSI\Dropbox\Windmill\Muath)

16 Units

Unit system:	SI (MKS)
Length/Displacement	mm
Temperature	Kelvin
Angular velocity	Rad/sec
Pressure/Stress	N/m ²

17 Material Properties

Model Reference	Properties	Components
	<p> Name: Plain Carbon Steel Model type: Linear Elastic Isotropic Default failure criterion: Max von Mises Stress Yield strength: 2.20594e+008 N/m² Tensile strength: 3.99826e+008 N/m² Elastic modulus: 2.1e+011 N/m² Poisson's ratio: 0.28 Mass density: 7800 kg/m³ Shear modulus: 7.9e+010 N/m² Thermal expansion coefficient: 1.3e-005 /Kelvin </p>	<p> SolidBody 1(Cut-Extrude1)(Bearing Housing-1), SolidBody 1(Cut-Extrude1)(Bearing Housing-2), SolidBody 1(Cut-Extrude4)(Blade Support-1), SolidBody 1(Cut-Extrude4)(Blade Support-2), SolidBody 1(Cut-Extrude4)(Blade-1), SolidBody 1(Cut-Extrude4)(Blade-2), SolidBody 1(Cut-Extrude4)(Blade-3), SolidBody 1(Mirror1)(Shaft-1), SolidBody 1(OuterRace)(radial ball bearing_68_am-1), SolidBody 1(Fillet)(thrust ball bearing3_68_am-1) </p>
Curve Data:N/A		

18 Loads and Fixtures

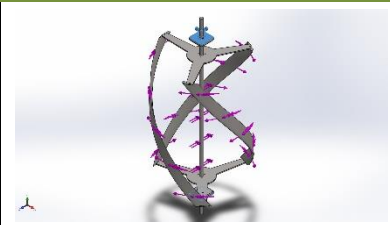
Fixture name	Fixture Image	Fixture Details		
Fixed-1		Entities: 2 face(s) Type: Fixed Geometry		
Resultant Forces				
Components	X	Y	Z	Resultant
Reaction force(N)	-0.0294223	0.0759284	149.996	149.996
Reaction Moment(N.m)	0	0	0	0

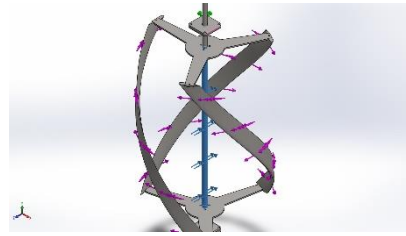
Load name	Load Image	Load Details
Torque-1		Entities: 3 face(s) Reference: Face< 1 > Type: Apply torque Value: 45 N.m
Force-1		Entities: 1 face(s) Reference: Edge< 1 > Type: Apply force Values: ---, ---, -150 N

19 Connector Definitions

No Data

20 Contact Information

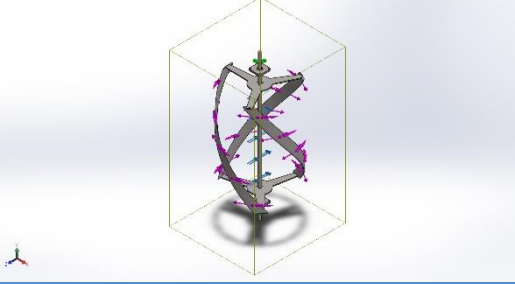
Contact	Contact Image	Contact Properties
Global Contact	 A 3D CAD model of a mechanical part, possibly a shaft or a bracket, is shown within a transparent wireframe bounding box. The part is rendered in a light gray color. Several purple and blue curved arrows are overlaid on the part, indicating the direction and magnitude of contact forces or moments. The part is positioned on a light gray surface, and a soft shadow is cast beneath it. A small red and blue icon is visible in the bottom-left corner of the image area.	Type: Bonded Components: 1 component(s) Options: Compatible mesh

21 Mesh information

Mesh type	Solid Mesh
Mesher Used:	Curvature based mesh
Jacobian points	4 Points
Maximum element size	20 mm
Minimum element size	4 mm
Mesh Quality	High
Remesh failed parts with incompatible mesh	On

Mesh information - Details

Total Nodes	121004
Total Elements	68094
Maximum Aspect Ratio	19.259
% of elements with Aspect Ratio < 3	94.1
% of elements with Aspect Ratio > 10	0.0676
% of distorted elements(Jacobian)	0
Time to complete mesh(hh:mm:ss):	00:00:07
Computer name:	LEOPARD

Model name:Windmill Static
Study name:Static Analysis(-Default-)
Mesh type: Solid Mesh



22 Sensor Details

No Data

23 Resultant Forces

Reaction forces

Selection set	Units	Sum X	Sum Y	Sum Z	Resultant
Entire Model	N	-0.0294223	0.0759284	149.996	149.996

Reaction Moments

Selection set	Units	Sum X	Sum Y	Sum Z	Resultant
Entire Model	N.m	0	0	0	0

24 Study Results

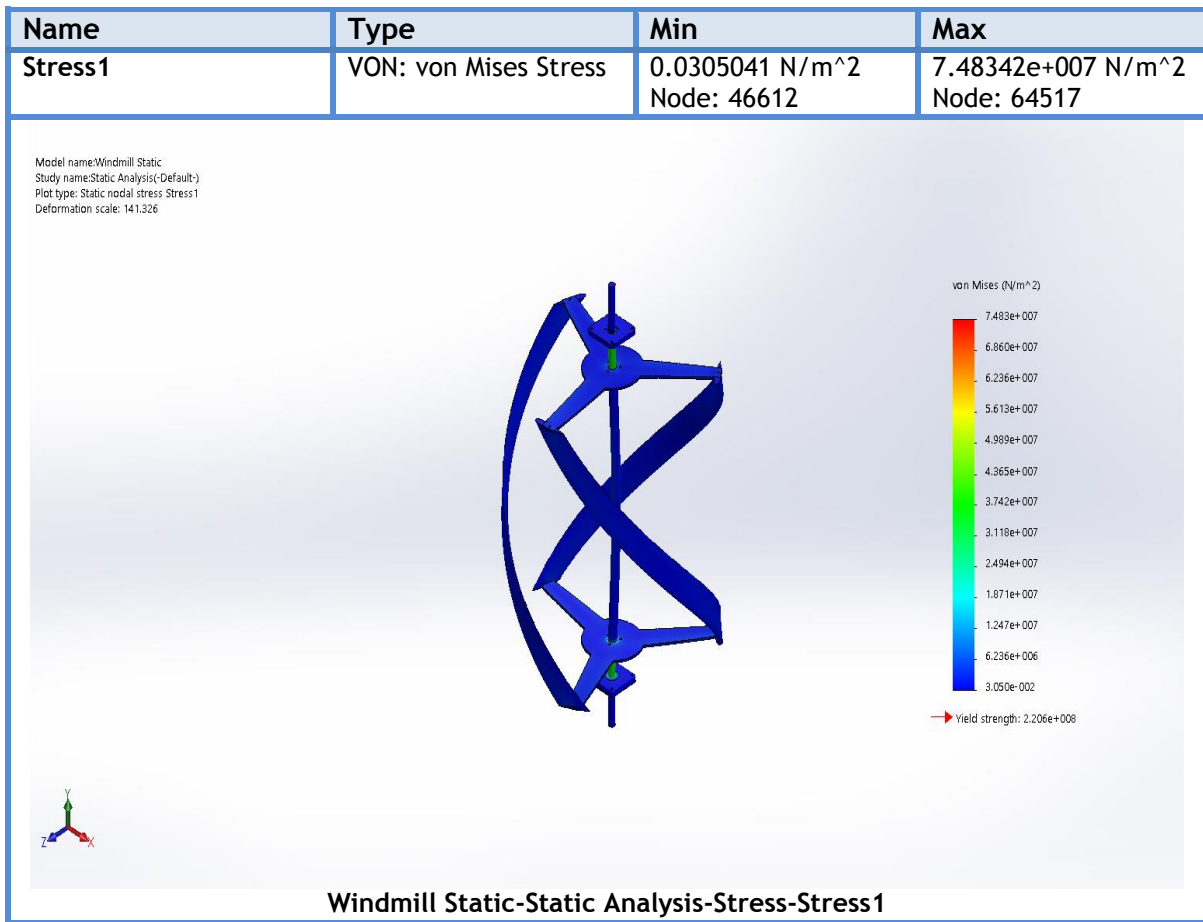

Name	Type	Min	Max
Displacement1	URES: Resultant Displacement	0 mm Node: 17	1.16784 mm Node: 73657

Model name: Windmill Static
Study name: Static Analysis-(Default-)
Plot type: Static displacement Displacement1
Deformation scale: 141.326

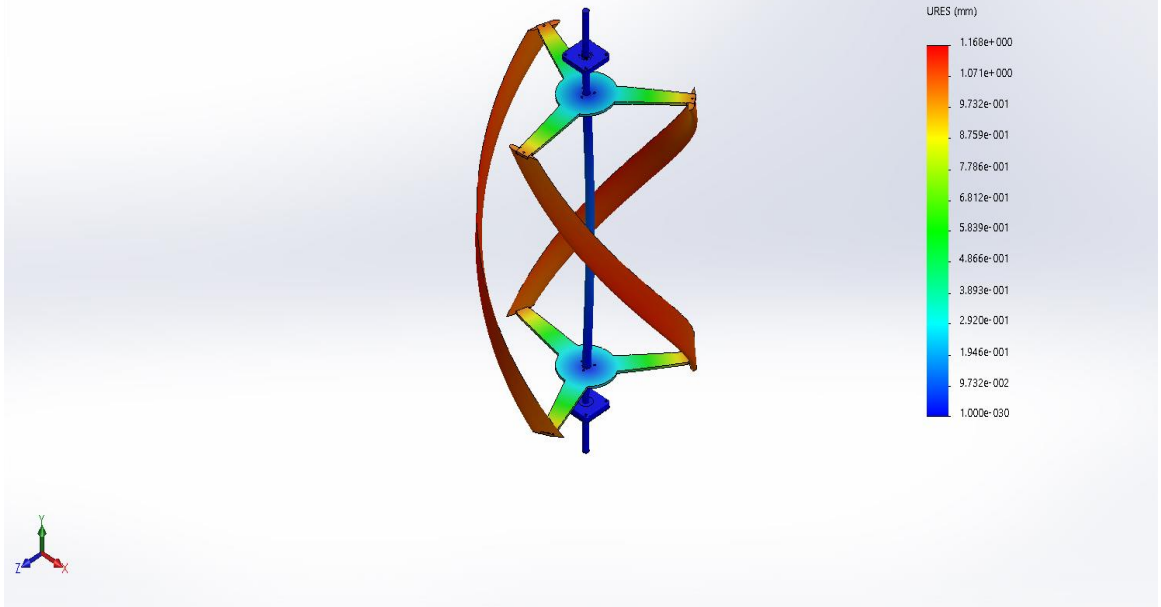

Windmill Static-Static Analysis-Displacement-Displacement1

Name	Type	Min	Max
Strain1	ESTRN: Equivalent Strain	1.3751e-013 Element: 27353	0.00026236 Element: 37954

Model name: Windmill Static
 Study name: Static Analysis-(Default-)
 Plot type: Static strain Strain1
 Deformation scale: 141.326

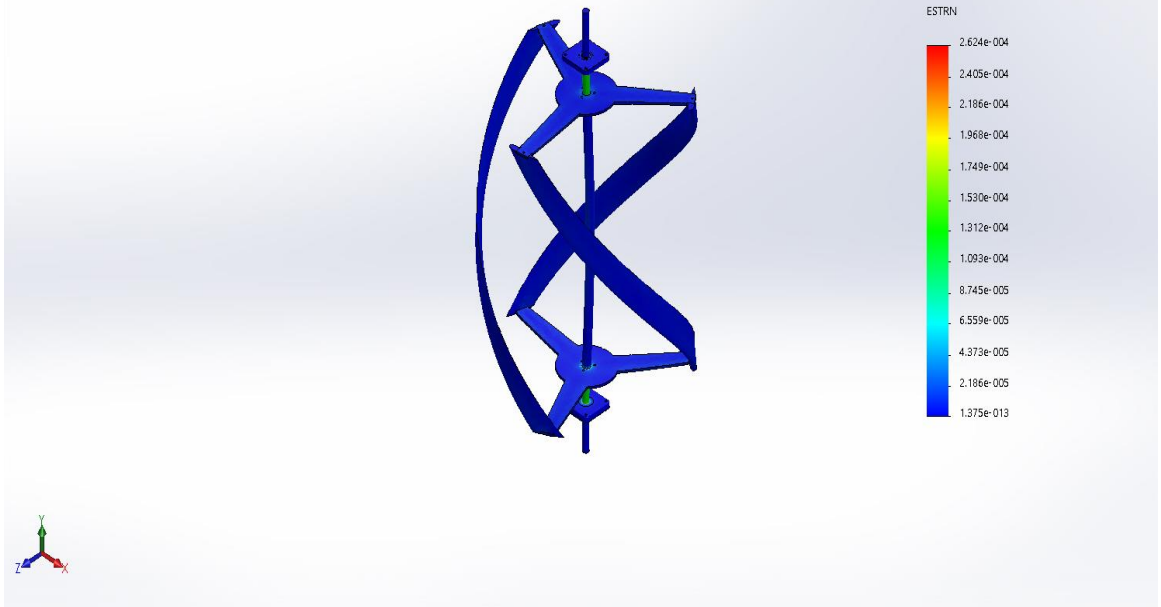

Windmill Static-Static Analysis-Strain-Strain1

Appendix B: 2D Drawing of Parts

