



**جامعة الأمير محمد بن فهد**  
**PRINCE MOHAMMAD BIN FAHD UNIVERSITY**

**College of Engineering**

**Department of Electrical Engineering**

Spring 2018-19

**Senior Design Project Report**

**Smart Energy Metering and Control System**

**Team Members**

	<b>Student Name</b>	<b>Student ID</b>
1	Khalid Al-Otaibi	201500251
2	Ahmed Ananzi	201501178
3	Abdullah Abaoud	201402809
4	Mohammed Dhameri	201303744

**Project Advisors:**

Advisor Name: Mr. Saifullah Shafiq

## *Abstract*

An energy meter is a device used to monitor the electricity utilization/consumption. Meters usually involve real-time or near real-time sensors data to calculate current, voltage and power. The main objective of this work was to design a single-phase smart energy meter using instantaneous power calculation. The device can be utilized to measure the amount of electric power consumed by electrical appliances. One of the goal is to monitor the consumption of electric energy using both current and voltage signal from power system. Voltage and current signal are sampled and analyzed by using Arduino. The device is embedded with WiFi control switching operation, i.e- to turn on/off the appliances at any time remotely via a software developed in Android Platform named with PMU. An Arduino code is developed to measure the various circuit parameters including current voltage, power factor (PF), real power consumption and reactive power. The system is also embedded with sensitivity measurement module and the values are displayed regularly. To control the various appliances, a mobile application is developed and integrated with the system. WiFi enabled energy metering system can be utilized to control the appliances remotely.

## Table of Contents

<i>Abstract</i> .....	2
1. Introduction.....	5
1.1 Project Definition.....	5
1.2 Project Objectives .....	5
1.3 Project Specifications.....	5
1.4 Product Architecture and Components .....	6
1.5 Applications: .....	9
2. Literature review.....	9
2.1 Project Background .....	9
2.2 Previous Work .....	10
2.3 Comparative Study .....	14
3. System Design .....	15
3.1 Design Constraints .....	15
3.1.1 Design Constraint: Engineering Standards .....	16
3.1.2 Design Constraint: Safety.....	16
3.1.3 Design Constraint: Cost .....	17
3.2 Design Methodology .....	17
3.3 Product Subsystems and Components.....	19
3.3.1 Product Subsytems1:.....	19
3.3.2 Product Subsytems2 :.....	22
3.3.3 Product Subsytems3:.....	22
3.3.4 Product Subsytems4:.....	23
3.4 Implementation.....	24
4. System Testing and Analysis .....	29
4.1 Subsystem 1: Power Meter.....	29
4.2 Subsystem 2: Automated Relay Switching .....	32

4.3 Subsystem 3: Power factor, Energy.....	34
4.3 Subsystem 4: Voltage to Load Sensitivity .....	36
4.3 Overall Results, Analysis and Discussion.....	37
5. Project Management .....	40
5.1 Project Plan .....	40
5.2 Contribution of Team Members .....	41
5.3 Project Execution Monitoring.....	42
5.4 Challenges and Decision Making.....	43
5.5 Project Bill of Materials and Budget.....	44
6. Project Analysis .....	44
6.1 Life-long Learning .....	44
6.2 Impact of Engineering Solutions.....	45
6.3 Contemporary Issues Addressed .....	45
7. Conclusions and Future Recommendations.....	46
7.1 Conclusions .....	46
7.2 Future Recommendations.....	47
References.....	48
Appendix A: Progress Reports.....	50
Progress Report 01 .....	50
Appendix B: Bill of Materials.....	52
Appendix C: Datasheet .....	54
Appendix D: Program Code.....	59
Appendix E: Operation Manual .....	66

# 1. Introduction

## 1.1 Project Definition

In this project, a smart energy meter is designed which is used to measure voltages and current to calculate power consumption. This would enable us to calculate electricity units consumption and control home appliances by using WiFi enabled control device with integrated mobile application and voice recognition software developed in Android Platform. The design of the proposed circuit can be extended to various applications includes: as GSM based energy meter and RFID based energy meter.

To design a smart energy meter that will have the following functions

## 1.2 Project Objectives

The main objective of this project are:

- a. Increase public awareness about impact of high electricity consumption
- b. Encourage adoption of energy conservation, efficiency and demand control measures
- c. Demonstrate smart energy metering and automated appliances control
- d. Make a single solution to monitor the energy consumption and control of appliances that is one of the solution provided for constructing smart HOMES.

## 1.3 Project Specifications

The project will involve the design of a smart energy system that will perform to the following target specifications:

- 1) Assumes home powered from grid (220V, 60Hz)
- 2) Digitally measure consumption of electricity by measuring current, voltage, power factor.
- 3) Digitally measure consumption of electricity by measuring voltage to load sensitivity and energy consumed.
- 4) A mobile application is developed in Android Platform to remotely communicate with the Main Control Energy system.
- 5) Voice recognition and controlling the device power supply.

- 6) WiFi enabled appliances/load control switching control system
- 7) Apply control measures to reduce consumption
- 8) Control all appliances remotely to save energy
- 9) Compact design with a dimension of 10.5 in \* 8.5 in \* 2 in.
- 10) The system is portable.

### 1.4 Product Architecture and Components

The project is divided into several parts to make it easy to handle and test. The main part of the project is to build a smart meter that will measure and monitor the power consumption.

In first phase, we use voltage and current sensors to measure voltages and current and then calculate power to be shown on LCD by using Arduino Microcontroller.

The second phase includes researching and implementing an accurate way to measure power factor

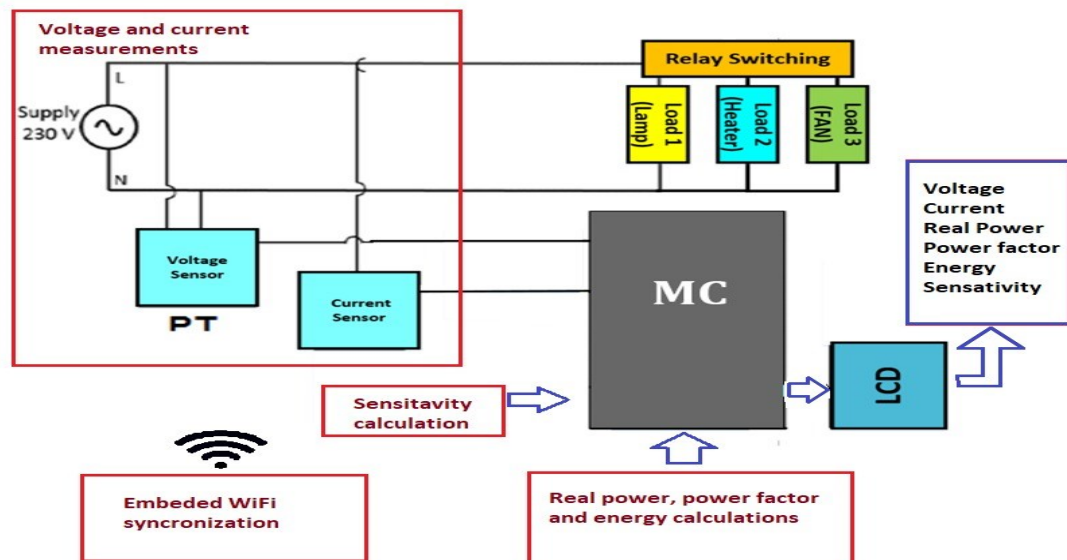

Figure 1 Internal Block Diagram

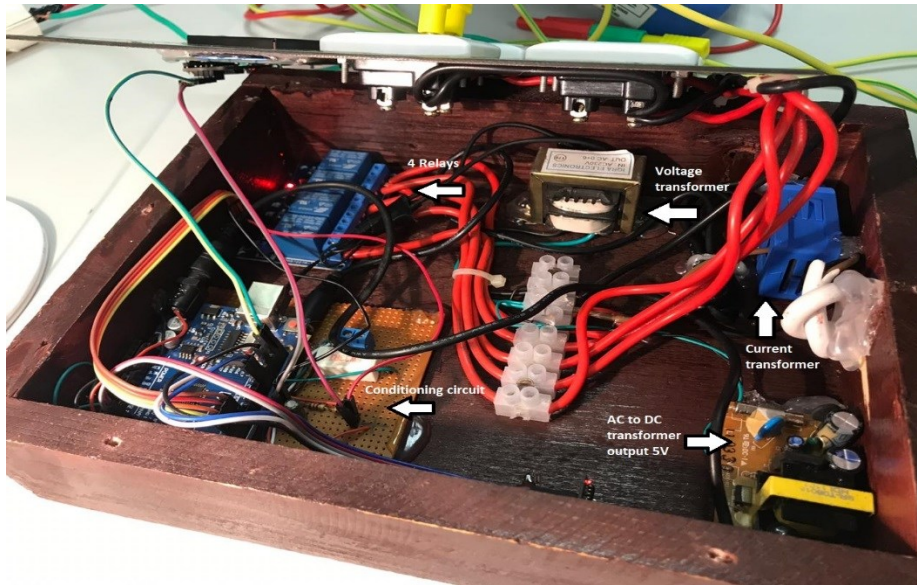

Figure 2 Smart Energy Metering and Control System

In third phase, we have used Four relays and connect our controller with internet using ESP8266 internet module. The main task is to operate our home appliances by using IoT. The block diagram is shown in Figure 2.

In this project, we have developed a way to measure voltage to load sensitivity. The block diagram of the system is shown in Figure 1. The following tasks were performed while designing the smart energy system. There are:

- Accurate power measurements
- Comparative study of current transformer and current sensor for accurate calculation
- Work on user interface to control the loads
- Test and analyze each subsystem and make necessary improvements.
- Integrate all subsystems and perform final testing.
- Write final report and presentation.

A list of components used in this project are listed below.

### **A. Battery Source and Voltage Regulator**

An AC source of 220V is utilized to power up the whole circuit. Voltage regulated circuit is used to convert 220VAC into 5V using a dedicated circuit.

### **B. Current Sensor**

A current transformer (CT) is utilized to measure AC current passing through the circuit. The current flowing in the secondary coil is proportional to the current in its primary coil. In this project, we have selected SCT-013 current sensor.

### **C. Voltage Sensor**

Voltage sensor made from the step-down transformer. It has high accuracy for voltage and power measurement and it can measure up to 380V AC. It is simple to use and highly accurate.

### **D. LCD 20 x 4**

LCD (Liquid Crystal Display) screen is an electronic character display module and find a wide range of applications. A 20x4 LCD display is very simple module and is mostly used in various devices and circuits. These modules are preferred over seven segments and other multi segment LCDs.

### **E. Arduino UNO**

The Arduino Uno is a microcontroller control board based on the ATmega328. It has 14 digital I/O pins (in which six can be used as PWM outputs), six analog inputs, a 16 MHz ceramic resonator, a power jack, a USB connection, and a reset button.

### **F. ESP 8266**

The ESP8266 is a cheap Wi-Fi module with full TCP/IP stack and microcontroller capability produced by Shanghai-based Chinese manufacturer Espressif Systems. The chip 1<sup>st</sup> came to the attention of western makers in Aug-14 with the ESP-001 module, made by a third-party manufacturer Ai-Thinker.

### **G. Relay**

This is a 5V 4-channel relay interface board, and each channel needs a 15-20mA driver current. It can be used to control various appliances and equipment with large current. It is equipped with high-current relays that work under AC250V 10A or DC30V 10A. It has a standard interface that can be controlled directly by microcontroller.

### **1.5 Applications:**

- a) Measure consumption of electricity at homes.
- b) Monitor consumption of power and voltage to load sensitivity
- c) Enable smart control of electrical appliances
- d) Optimal Battery Placement
- e) Controlling renewables Generation
- f) Controlling Electric Vehicles Charging Rate.
- g) Controlling loads at via an app using hands or voice.

## **2. Literature review**

### **2.1 Project Background**

In smart metering mechanism, the electronic power meter is utilized to fully remote control the appliances, anti-tampering or anti-theft mechanisms, diagnostics, consumption and power peak analysis, time-variable tariffs, fault alerts, and other possible instances. The use of the “Power-Line Communication”, known as PLC or relevant wireless and wired types of technologies for the connection of the service provider to the meter allows these aforementioned features compatible and realistic with the future protocols of smart grid.

Smart energy meters are typically digital meters that work in substitute for the old analog meters many homes use for the recording of their electrical use. Details of energy consumption can be transmitted by digital meters frequently to the utility as opposed to the conventional analog meters that need transmit the information using a meter reader. Home electric energy use is being recorded hourly or less. With smart meters, monitoring your consumption is easier and accurate to enable you make any informed decisions regarding the energy or controlling

the use of energy. Some feature sets of the meter are capable of notifying about power outage or enable the switching on or off of the electricity service of the utility.

## 2.2 Previous Work

In this section, we have highlighted some of the previous works that are relevant to the proposed design. A comparison of the proposed design is made in next section of this chapter.

### a) Design of an Automatic Meter Reading System

This project discusses the process of the Automatic Meter Reading system (AMR), which is a programmable meter reading, integrated, and control system as opposed to the usual telephone networks. As expected, the AMR is an automated type of system, having a two-way system that enables utility meter management and remote reading. The management processes and meter reading are free from the involvement of humans. Efficiency, cost-effectiveness, speed, and accuracy are different benefits from the adoption of AMR systems. The entire system operates on the basis of the current telephone networks; consequently, anywhere a telephone network is reachable, this service works. These are fully automatically and electronically achieved, thereby putting an end to the semi-automatic (and manual) meter entry and reading, reading errors, billing floats, and callbacks [1].

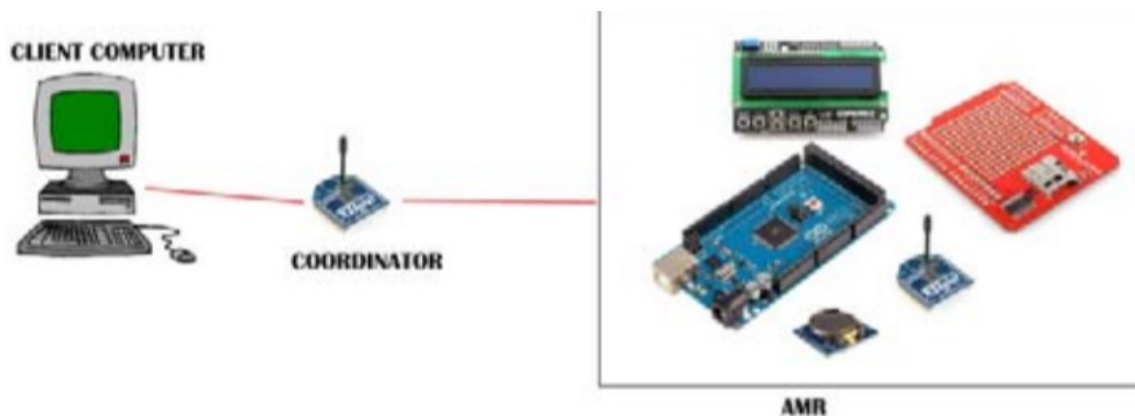

Figure 3 Automatic Meter Reading System

### **b) Data Reading from Smart Energy Meters in a Modern Metering Infrastructure**

Data frequently gathered through the conventional method from electricity meters on the basis of people displacements have the tendency of being substituted from the electricity meters, with respect to the people moving houses; have the tendency of being substituted by modern solutions: the Automated Meter Reading and the drive-by. Drive-by is just the mobile devices, moving close to the meters, gathering data. There are less personnel and nothing like manual readings. Moreover, the AMR is the automatic collection of data directly from the meters and transferring it to a particular central computer.

AMR has benefits like subsidized costs to read meter, accessing meters easily, which can be otherwise hard to access due to their security measures or positions, higher fraud detection, real-time pricing supported, decreased read-to-bill time, and many more. Smart meters are very essential to AMR. Besides from their conventional functions, reading the consumptions requires smart meters to be capable of sending the readings directly across the communication lines. Many advanced systems require the meter to identify consumers' address as well as the activation or deactivation of internal modules. The required requirements must be satisfied by a meter, particularly for getting the data read from the convention area of the meter as well as providing a response to the commands provided by the lines.

A particular infrastructure is required by the AMR. These include the unidirectional system, which implies that there is a periodical sending of data by meters, or could be bidirectional, where the possibility of getting the system managed is added, an instance is the connection and disconnection of users, for the gathering of the data directly from the meters based on set standards, for the grouping of the meters and more. This infrastructure is regarded as Advanced Metering Infrastructure, represented as AMI. AMI has a communication channel, which has to make sure the data collector otherwise known as gateway and the data collector of the communication smart meter otherwise known as gateway of the central computer exist. The solutions include the wired solution or the wireless solution. The preferred solution has to consider the distances that exist between the devices, while considering the current infrastructure and associated financial implications [2].

### **c) IR Remote Controlled Home Automation**

The IR based wireless type of communication system for the control of home appliance is discussed in this work. The entire process is controlled using Arduino. A few commands are sent with the use of IR DVD/TV/MP3 remote to controlling system of the AC home appliances.

When the signal had been received from the IR remote, the related signal is sent by Arduino to relays that are in charge of getting the home appliances switched ON or OFF with the help of the relay driver. This is quite simple. A code is sent when a button is pressed on the remote just like train of encoded pulses. 38 Kilohertz of modulating frequency is used. The TSOP1738 sensor receives the pulses and Arduino reads and decodes directly to a hexadecimal values after comparing the decoded value with the pressed button's predefined hexadecimal value. Any match from this makes Arduino operate as expected and the 16x2 LCD presents the corresponding result with the use of the suitable commands [3].

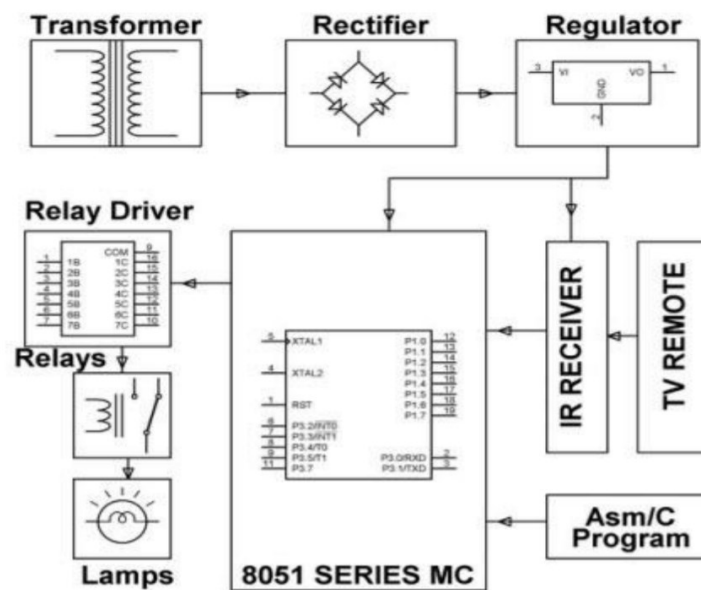

Figure 4 Block diagram of IR remote controlled home automation.

#### d) SMS-based Reconfigurable Automatic Meter Reading System

Most utility organizations and engineers now popularly use the AMR system. Besides just substituting the manual meter reading, AMR uses an automatic procedure, with lots of benefits, including enhanced load profile, higher speed, real time energy cost, automatic billing invoice, alarm warning, load management, tamper detection, and remote power switch on or off. In the near future, AMR will become renowned. Presently, there is a constant evolvement of AMR schemes. An integration of the benefits these digital energy meters provide makes contemporary AMR systems very advanced, with adaptable features as opposed to the past systems of many years ago [4]. The emergence of these recent communication technologies, including their constantly reducing costs and competitive markets make the traditional meter reading system extinction appear unavoidable [4].

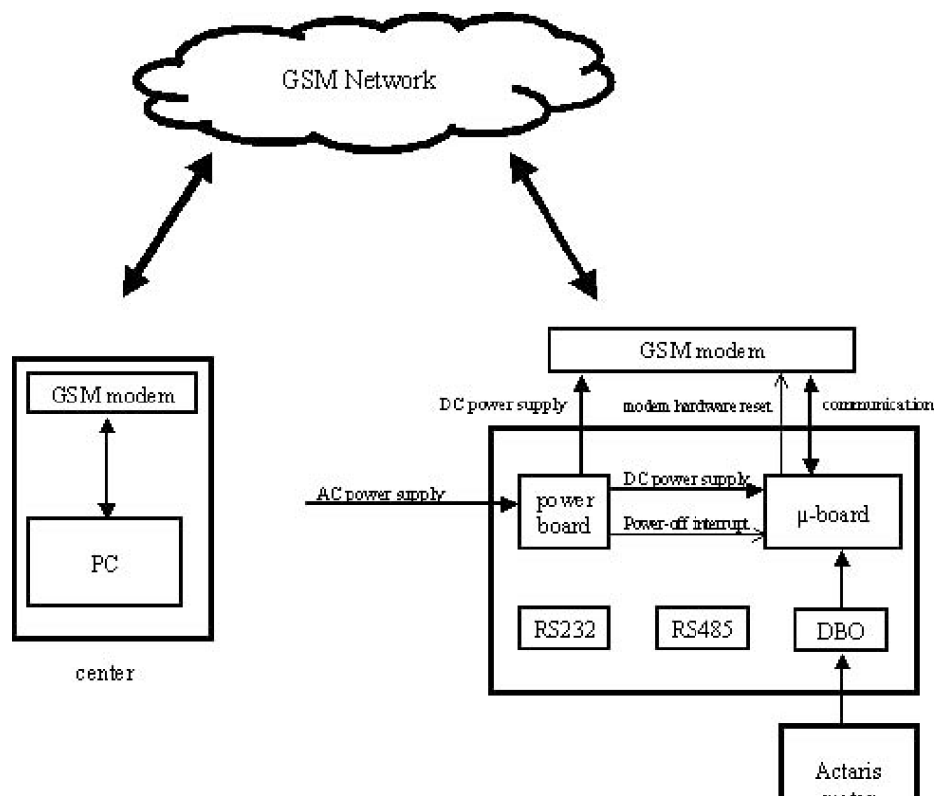

Figure 5 SMS based system

## 2.3 Comparative Study

Increased growth of energy use makes the development of energy conservation an issue of concern, particularly for increased **tariff** in the Kingdom of Saudi Arabia. It is utmost desired to investigate and implement the mechanism to enhance awareness, devise new methods to reduce the consumption and better utilization. Since the development of energy, conservation for homes and commercial buildings is increasing, providing suitable methods to assess energy usage efficiently. Several efforts have been made and are discussed in the literature part of this chapter.

In our work, we have proposed a simple, more economical solution for energy conservation. The method is implement with accurate calculation of line parameters, can determine the various values like voltage, current, power factor, active and reactive powers, power calculation and energy usage. In addition, the system is equipped with WiFi module to control the appliance remotely. This would help the consumers with better option to monitor the energy usage and at the same time, would have an option to control the home appliances remotely. This low cost solution is mostly suitable for domestic applications.

Table 1 Comparative Study Table

Projects	1	2	3	Our Project
Smart meter	√	√	√	√
Communication GSM, Zigbee, WiFi	Zigbee	Wi-Fi	GSM	Wi-Fi
monitoring	√	√	√	√
Energy	√	√	√	√
Sensitivity Measuring				√

## 3. System Design

### 3.1 Design Constraints

In this chapter, we will discuss the various design constraints and available options for implementing the various stages of the smart energy metering and remote controlling of the appliances. The Arduino programming was used for the design of this project. This chapter focuses on the design steps of the energy meter implementation. Moreover, the embedded system is an essential and digital system having a dedicated operation within a massive electrical system or mechanical system, usually having real-time computing limitations. It is incorporated as one of the complete devices, which usually include mechanical and hardware parts. On the contrary, a personal computer or the general-purpose computer is made flexible to satisfy the different needs of the end-users. Most of the devices used nowadays are controlled by the embedded systems.

The modern embedded systems' operations are on the basis of microcontrollers alongside peripheral interfaces and/or the integrated memory, while the ordinary microprocessors (with the use of external chips for the peripheral interface circuits and memory) remain popular, particularly in complex systems. In any of these cases, there are different types of the processor(s) applied, which include the general purpose ones and the extremely specialized ones in specific computation categories, or including the custom designed for the underworking application.

Generally, an energy or electric meter measures the quantity of consumed electric energy by an entity (electrically powered device, residence or business). Typically, energy meters have calibration in billing units – kilowatt-hour (kWh). The energy consumed and billing cycles are set up by the periodic readings of the electricity meters amid a cycle. For the choice of energy savings for a particular time, the settings of the meters can be used for the demand

measurement, including the maximum power used for a particular interval. Electric rates are allowed by “time of day” metering to change during the day, for usage recording amid the off-peak lower-cost intervals or the peak high cost intervals. Additionally, other types of meters are designed with demand response load, which shed amid peak load intervals. Since the 1880s when electric energy spread commercially, it turned out extremely essential that an electric energy meter, just like the gas meters around, was necessitated to appropriately get customers billed for the energy costs, rather than being billed for a particular fixed lamp number each month. The majority of the research kinds of meter were created. A DC electromechanical meter was first operated by Edison alongside a straightforward reading register, but rather got the electrochemical metering system designed, which made use of an electrolytic cell to sum up the existing consumption [5].

### ***3.1.1 Design Constraint: Engineering Standards***

Design constraints are conditions that are needed to be utilized to execute the project successfully. Design constraints helped in narrowing down the available choices and its standardization. Design constraints are sometimes challenging to be addressed but they are helpful to meet the demand and operate the devices safely. For the proposed design, engineering constraints are summarized in this section [6].

- a. The device should be capable to withstand the temperature of 55 °C in summer. This high temperature constraints are because of severe weather conditions in Saudi Arabia.
- b. The current rating determine the number of appliances to be connected to the given energy metering. It is required to design such an energy metering system for household load or should be capable to withstand the commercial energy usage.
- c. The device should be capable to give accurate reading in severe summer weather.
- d. The devices should withstand with the environmental conditions including sand storms as well as rainy conditions.

### ***3.1.2 Design Constraint: Safety***

Smart energy meters are equipped with radio waves to allow readings to be taken remotely or could be utilized for controlling the appliances. There is fear that the radiation emitted from energy meter might cause some health risk. However, it is proven that smart meters are very safe to be utilized in home appliances. The electromagnetic spectrum have been used for decades to transmit radio and television broadcasts, mobile phone services and wireless internet access without any dangerous [7].

Working with the AC main may cause some fear for consumers to handle. However, the proposed design is well isolated to be utilized. There is no safety risk for electricity consumer in utilizing the proposed design.

Moreover, the high voltage can cause damage to human life. It is highly recommended to be utilized in safe environment. Safety should be considered for using such devices.

### **3.1.3 Design Constraint: Cost**

Most of the smart energy metering solutions provided are with high cost. The cost of equipment and implementation made it difficult for consumers to adopt the solution. The electricity providing companies have a rising concern of using such high cost solution.

For our proposed work, it is very economical and can be easily implemented in residential as well as commercial sites. The total cost of such device is less than 500 SAR which make it more appropriate solution to be utilized. The electricity providing companies are in need to use such sophisticated system to implement for commercial and residential areas.

## **3.2 Design Methodology**

For subsystem one(power measurement), while thinking about the design we have set three must haves that the design must have which are:

- No DC measurement because our next step is measuring the power factor
- The controller cannot read below zero values
- Both Current and Voltage need to be accurate

The power factor calculation we found that implementing a Schmitt trigger circuit will do the job well, however, after much research we found a way that we can calculate the power factor using Arduino IDE library functions as it shown in Appendix D. For this subsystem it needed to be:

- Accurate
- Economical
- Precise

Third subsystem which is expanding the design we needed it to be of high quality, easy to use and reliable. For voltage to load sensitivity, we needed it be accurate and find a way to implementing it, therefore, so much research has been done on it, as it never been done before.

### **A. Unit of Measurement**

The most simple unit of measuring the electricity is the kilowatt-hour [kWh], which is equal to the amount of power consumption used by a load of one kilowatt over a period of one hour, or 3,600,000 joules. Power consumption is normally measured in watts, but averaged over a period, most often a quarter or half hour. Reactive power is measured in "thousands of volt-ampere reactive-hours", (kvarh). By convention, a "lagging" or inductive load, such as a motor, will have positive reactive power. [4] Only in the presence of external measuring pulse. The number of pulses measured can be converted to current.

Number of pulses measured in 5sec = x

Number of pulses measured in 1sec = x/5;

Number of pulses measured in 60 sec = (60\*x)

### **B. Hall Effect Based Measurements Technique**

In the proposed design, the current used is based on Hall Effect sensor. The Hall Effect sensor based measurement is very popular method for measuring magnetic field and can be found in many state of the art devices for various applications. It may include vehicles speed as wheel speed, as motion sensor, for motor speed measurements devices i-e tachometer. MEMS compasses and in proximity sensors [9].

In Hall Effect sensor, current flow in a straight path in Hall Effect plate (sensor). If a magnetic field near the conductive plate is disturbed, the straight flow of the charge get disturbed and deflected to one side of the conductive plate and the +ve charges on the other side of the conductive plate. Thus, a voltage difference is created within the sensor and can be utilized to measure the speed of the motor.

The basic Hall Element of the Hall Effect magnetic sensors mostly provides very small voltage of only a few microvolts, hence it is necessary to manufacture high gain built-in- amplifiers within sensor IC. In Figure 5, Hall Effect sensor is connected with high gain amplifier within the IC and an analog output voltage is obtained in the circuit. In Figure 6, the output of amplifier is fed to Schmitt trigger circuit. The Schmitt trigger circuit is a logic input type that gives two different voltage levels, thus the output can be utilized as digital signal. The output sensors provide 2 output states, either "ON" or "OFF". This type of circuit is useful to avoid noisy input and signals with abrupt and unexpected variation in the signals.

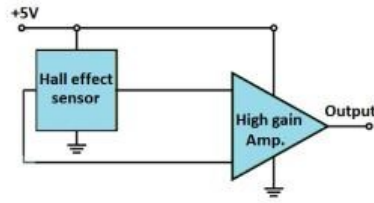

Figure 6 Basic Hall Effect sensor circuit

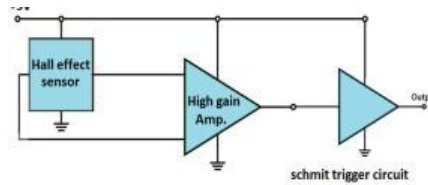

Figure 7 Hall Effect sensor circuit with Schmitt trigger circuit

The Hall Effect based measurement setup is very important to accurately determine, provides a relatively simple method to measure the change in magnetic field, and can be easily deployed in such applications. Because of its simplicity, low cost, and fast turnaround time, Hall Effect sensor, based measurement techniques are indispensable in the industry, research and in laboratories.

### 3.3 Product Subsystems and Components

In this project execution, we have started our work by looking for voltage and current sensors. A number of sensors are available online but it is hard to find them in local market. We got SCT-013 & Voltage sensor and design procedure and the selection of the rest of the component were based on this sensor. The components used in this project with details are given below.

#### 3.3.1 Product Subsystems1:

- 9 volt battery. It is not very reliable as you need to switch of the device every time to change the battery so the energy measurement will be lost
- Power up the Arduino using a voltage regulator LM-2596S IC which will work hand in hand with the battery option.
- Using the a voltage transformer 230V to 5v and a AC to DC circuit to power up the circuit, this will make sure the device keep running as long as it plugged in .
- Using a voltage sensor ZMPT101b to get the voltage
- Using ACS712 Current Sensor.
- Using a CT SCT-013 for current sensing
- Using a voltage transformer for sensing voltage.

- Using a power measurement IC to measure both current and voltage
- LCD (Liquid Crystal Display) A 20x4 LCD display is very simple module and is widely used in various devices and circuits
- Controller we needed a brain to perform all the calculations and we chose ATmega328 for ease of use and vast library.

Below you will see a comparison table between the devices we used to implement this subsystem as well as a brief explanation on the products we chose.

Table 2 Comparison of subsystem 1 products

	<b>CT</b>	<b>Voltage transformer</b>	<b>Voltage sensor</b>	<b>Current sensor</b>	<b>Power meter IC</b>
<b>Easy availability</b>	√	√	√	√	
<b>Can be replaced easily</b>	√	√	√	√	
<b>Economical</b>	60sr	140sr	150sr	90sr	1500-5000sr
<b>Accurate</b>	√	√	√		√
<b>Can use emon.lib with the selected components</b>	√	√		√	

## Current Sensor

A current transformer (CT) is a type of transformer, which is used to measure alternating current as shown in Figure 8. It flows a current in its secondary coil, which is proportional to the current in its primary coil. In this project, we have selected SCT-013 current sensor.



Figure 8 Current transformer

## Voltage transformer

Voltage sensor made from the step-down transformer as shown in Figure 10. It has high accuracy for voltage and power measurement and it can measure up to 380V AC. It is simple to use and highly accurate.



Figure 9 Voltage transformer

## LCD 20x4

LCD (Liquid Crystal Display) screen is an electronic character display module and finds a wide range of applications as shown in Figure 10. A 20x4 LCD display is a very simple module and

is widely used in various devices and circuits. These modules are preferred over seven segments and other multi segment LCDs.

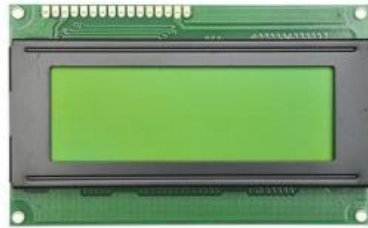

Figure 10 LCD used in the project

### Arduino Uno

The Arduino Uno is a microcontroller control board based on the ATmega328 as shown in Figure 11. It has 14 digital I/O pins (in which six can be used as PWM outputs), six analog inputs, a 16 MHz ceramic resonator, a power jack, a USB connection, an icsp header, and a reset button.



Figure 11 UNO used in the design

### 3.3.2 Product Subsystems2 :

For this subsystem we had to choose between two designs one that included a Schmitt trigger circuit, and the second included only Arduino library. For more economical reasons we chose the later design, as the first design will cost money on ICs that are not very raged.

### 3.3.3 Product Subsystems3:

- Relays it can be controlled using the same circuit
- Switches, needed to be controlled manually
- Esp8266 have a good range.
- HC-05 is a Bluetooth chip but it is not very raged and cant be used over long distances.

- IOS platform is very hard to create a program on it and not pay for it as it wont be able to be downloaded on your iPhone without it being uploaded to the apple store.
- Android platform can be used easily because google stores have programs that can help you get the app on your phone without it being on the store, it is also easier to create than the iPhone version.

### Esp8266

The ESP8266 is a cheap Wi-Fi module with full TCP/IP stack and microcontroller capability produced by Shanghai-based Chinese manufacturer Espressif Systems as shown in Figure 12. The chip 1<sup>st</sup> came to the attention of western makers in Aug-14 with the ESP-001 module, made by a third-party manufacturer Ai-Thinker.



Figure 12 ESP8266 used in this project

#### ***3.3.4 Product Subsystems4:***

To implement this we needed to preform the first subsystem and it needed to be measuring the voltage accurately so we used the same products to measure voltage to load sensitivity.

### 3.4 Implementation

The various design stages and relevant hardware implementation is discussed in this section. The various which factor which limit us to use such solution in described in details in this section.

#### A. Design 01

The design 1 is consisted of voltage transformer (VT) and current transformer. The voltage obtained at the output of VT is passed through conditional circuit to make it suitable to be used in Arduino controller as shown in Figure 13 with the corresponding waveform in Figure 14.

Figure 15

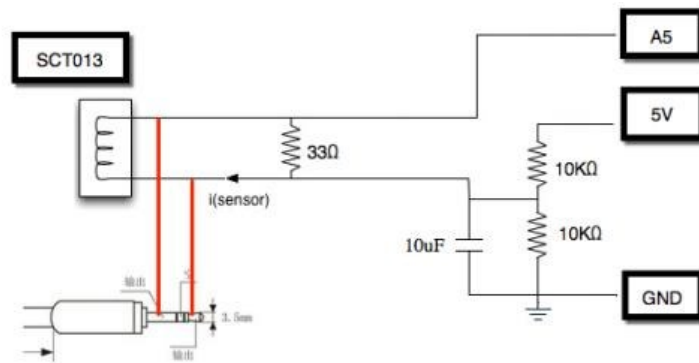

Figure 13 SCT-013 interface with Arduino Circuit Diagram (ADC)

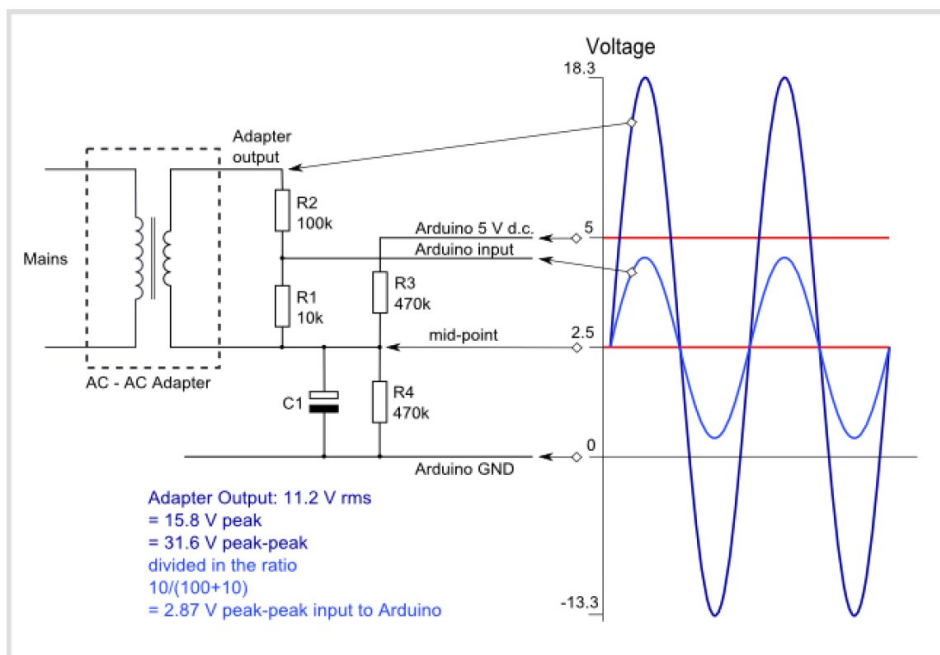

Figure 14 Voltage transformer conditioning circuit

### B. Design 02

The second approach is to use IC ADE 7757, energy metering IC. The out put of the energy metering is fed to controller for necessary calculation and showing the data the output LCD. The block diagram is shown in Figure 16. However, we were not fortunate to test it as it is very expensive and not available in local market

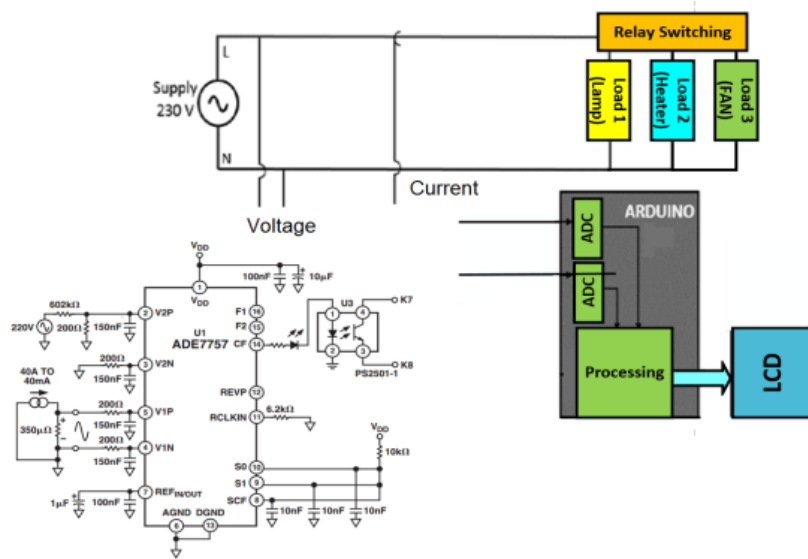

Figure 15 ADE7757 based energy meter circuit diagram

### C. Design 3

This strategy of using voltage sensor and current sensor, we have implemented and we could measure the voltage and current easily

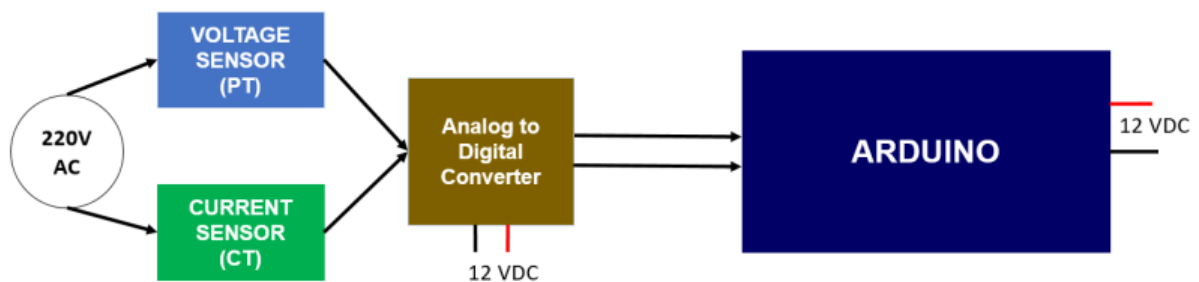

Figure 16 Proposed System Block Diagram

Figure 18 Proposed System Block Diagram

Although the above-mentioned circuits as given in Figures 16, can be used to measure the current and voltages of home. Design one is the best option because of the following reasons:

- Ease of execution
- Cheap components
- More practical

In D and E will discuss designs for subsystem 2

**D. Design 1**

Using Electricity monitoring library on Arduino IDE to measure mains voltage and current time difference, so we can display the power factor

**E. Design 2**

The circuit consists of Current transformer (CT) and Voltage or Voltage transformer (VT). Filtering capacitors in this circuit is important to removing power supply noise (voltage ripple) to insure logic gate works well shown in figure 17.

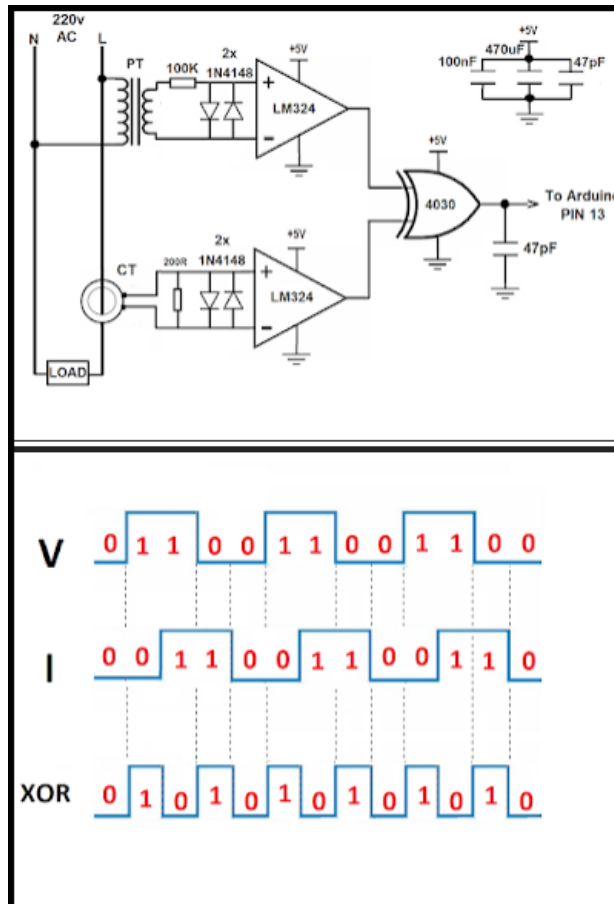

Figure 17 Design 2 Circuit and signal

For subsystem 3 we have only chose

#### **F. Design 1**

An automatic relay type of switching system was developed in this subsystem in order to get load switched remotely. Wi-Fi can be used as a means of communication and relays can be operated with the use of Wi-Fi with the help of mobile application.

There are some components in this subsystem, including [13]:

- Esp8266 Wi-Fi Module
- Mobile Application
- Arduino Uno
- 4-channel relay module

The software was developed by the team members in Android Platform that can recognize the instruction from the end user and controlling the units connected to the system remotely through a Wi-Fi. The Logo of PMU was used to represent the application.

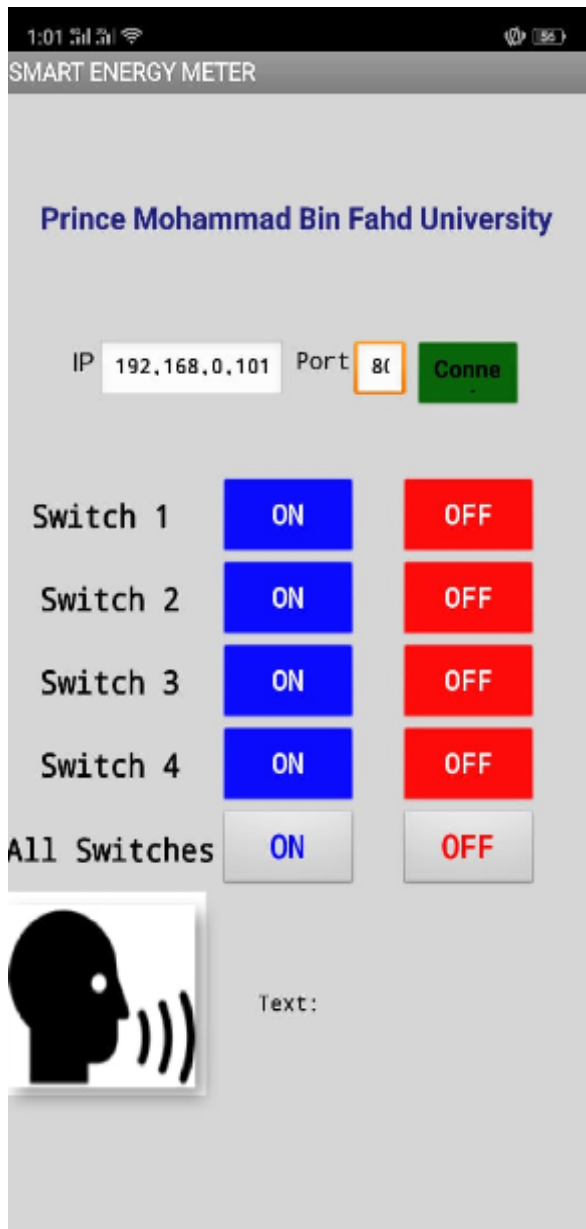

Figure 18 App used in the project

## 4. System Testing and Analysis

### 4.1 Subsystem 1: Power Meter

For the proposed work, the subsystem 1 is functioning as a power meter. The current and voltages values can be measured using the power meter. The PF can be measured by using the current and voltage waveform. The phase difference between the two quantities give us the PF. We can use different sensors for accuracy and monitor each sensor on different load for the test analysis [10]. Finally, we choose the most accurate sensor for our project. Following are the sensor name we used in our project:

1. SCT-013 (Current Transformer)
2. 220VAC - 6VAC Step Down Transformer ( Potential Transformer)

#### A. Voltage Sensor Selection:

We have tried two voltage sensors ZMPT101b and Transformer based voltage sensor, check both sensors results, and choose the accurate one for our project.

Circuit diagram of handmade voltmeter for Arduino and other controllers.

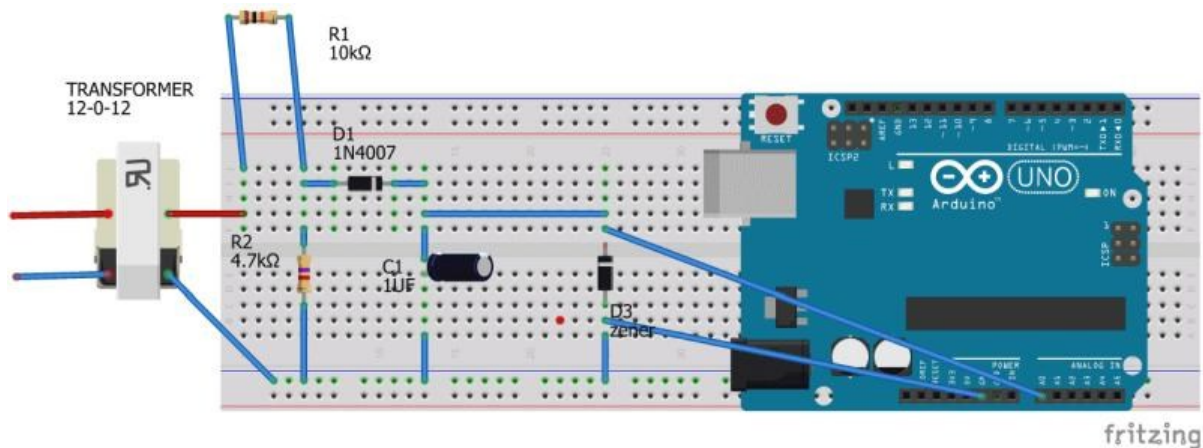

Figure 19 Potential Transformer With ADC

We have tested the circuit in simulation and it was working well in simulation. Then the circuitry was checked on the breadboard and had checked the result on Arduino serial monitor. Second sensor is ZMPT101b it is a Potential transformer based voltage-measuring module for AC Sources. We had checked this module as well and the circuit was working well. Sometimes, we have observed some junk values on analog pin that changed our result for a short interval of time. This had to be removed for more accurate results.

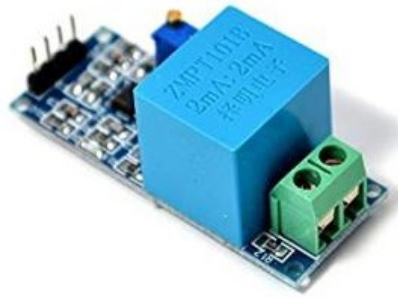

Figure 20 ZMPT101B Voltage Sensor

## B. Current Sensor Selection:

We will test two different current sensor ACS-712 and SCT-013 current sensor and check both sensor result. After testing, we will choose accurate one for our project [11].

ACS-712 Specification:



Figure 21 ACS712 Current Sensor

### Absolute Maximum Ratings

Characteristic	Symbol	Notes	Rating	Units
Supply Voltage	$V_{CC}$		8	V
Reverse Supply Voltage	$V_{RCC}$		-0.1	V
Output Voltage	$V_{IOUT}$		8	V
Reverse Output Voltage	$V_{RIOUT}$		-0.1	V
Reinforced Isolation Voltage	$V_{ISO}$	Pins 1-4 and 5-8; 60 Hz, 1 minute, $T_A=25^\circ\text{C}$	2100	V
		Voltage applied to leadframe (Ip+ pins), based on IEC 60950	184	$V_{peak}$
Basic Isolation Voltage	$V_{ISO(bsc)}$	Pins 1-4 and 5-8; 60 Hz, 1 minute, $T_A=25^\circ\text{C}$	1500	V
		Voltage applied to leadframe (Ip+ pins), based on IEC 60950	354	$V_{peak}$
Output Current Source	$I_{IOUT(SOURCE)}$		3	mA
Output Current Sink	$I_{IOUT(SINK)}$		10	mA
Overcurrent Transient Tolerance	$I_P$	1 pulse, 100 ms	100	A
Nominal Operating Ambient Temperature	$T_A$	Range E	-40 to 85	$^\circ\text{C}$
Maximum Junction Temperature	$T_J(\text{max})$		165	$^\circ\text{C}$
Storage Temperature	$T_{stg}$		-65 to 170	$^\circ\text{C}$

**SCT-013 Specification:**



Figure 22 SCT-013 Current Transformer

**Circuit Diagram:**

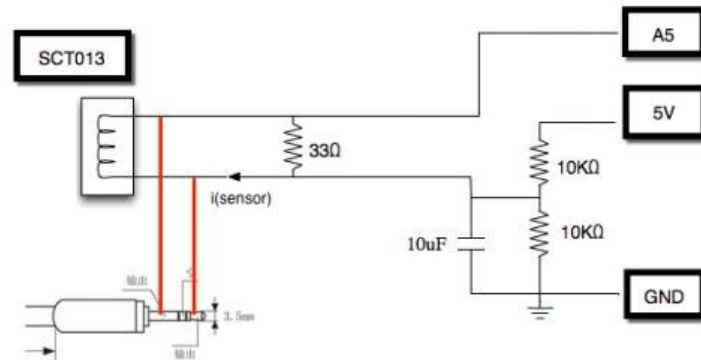

Figure 23: SCT-013 interface with Arduino Circuit Diagram (ADC)

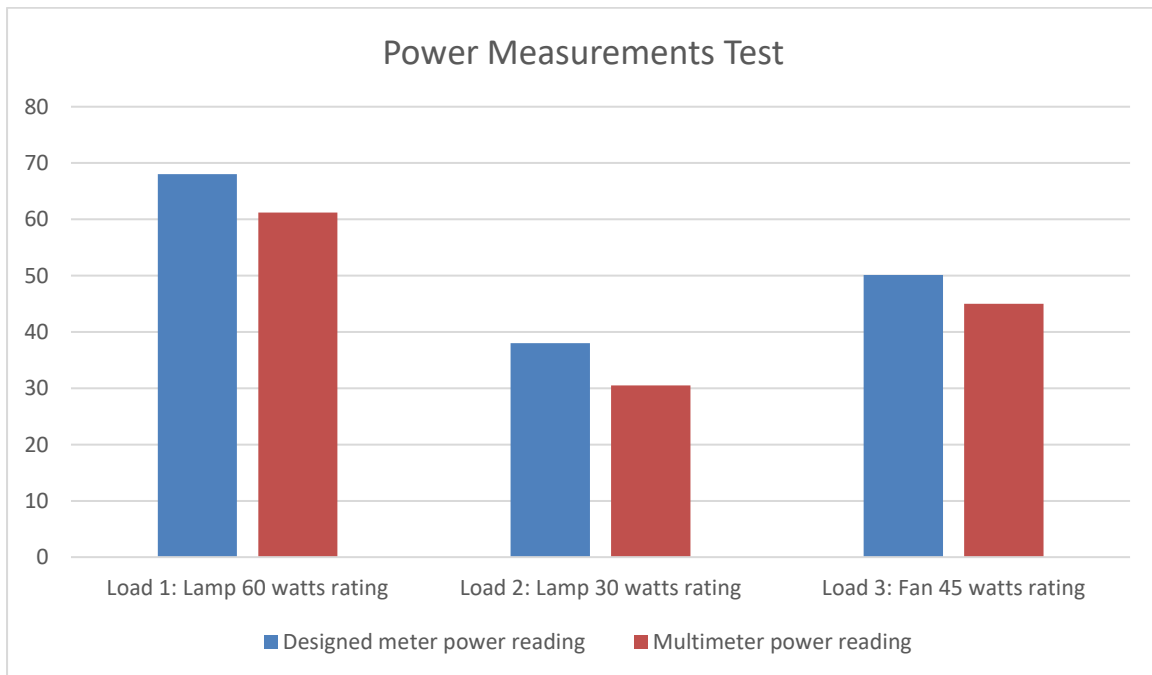

Figure 24 Designed power meter vs standard multimeter Power readings.

Table 3 Current, voltage, and power measurements across three different loads.

Loads	Current measurement (A)		Voltage measurement (V)		Power measurement (W)	
	Designed meter	Multimeter reading	Designed meter	Multimeter reading	Designed meter	Multimeter reading
Lamp 60 W	0.4	0.38	239	235	60.2	69.3
Lamp 30 W	0.26	0.25	239	235	32.2	37.3
Fan 45 W	0.30	0.28	239	235	45.5	50.1
Heater 1320 W	5.8	5.6	239	235	1322	1332

## 4.2 Subsystem 2: Automated Relay Switching

In this subsystem, we made an automatic relay switching system which is used to switch load remotely. We have used a Wi-Fi as a communication medium to and operate the relays by using Wi-Fi via mobile application. In this subsystem, the following components were used [12]:

1. 4-channel relay module
2. Esp8266 Wi-Fi Module
3. Arduino Uno
4. Mobile Application

### A. 4-Channel Relay Module

An automatic relay type of switching system was developed in this subsystem in order to get load switched remotely. Wi-Fi can be used as a means of communication and relays can be operated with the use of Wi-Fi with the help of mobile application. There are some components in this subsystem, including [13]:

- Esp8266 Wi-Fi Module

- Mobile Application
- Arduino Uno
- 4-channel relay module

### The 4-Channel Relay Module

This system has 4 channel relay interface board with 5 volts, in which the individual channel requires a 15 to 20 mA type of driver current. It is capable of being used for the control of different equipment and appliances alongside large current. There are high-current relays designed with it under the DC 30V 10 Amps or AC 250V 10 Amps. A standard interface is designed with it, which the microcontroller controls.

The figure below shows that the moment the signal port gets to the low level, there will be a lighting up of the indicator, while the opto-coupler 817c will then conduct (which transforms electrical signals based on light and capable of isolating the output and input electrical signals), while getting the transistor on, there will be an electrifying of the relay coil, while the relay which typically has an open contact will remain closed. At high level, the relay's closed contact will remain closed. Therefore, connecting and disconnecting any load is possible when the control signal port level is controlled [14]

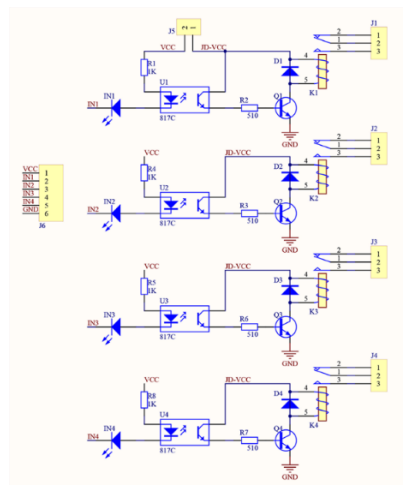

Figure 25 4-Channel Relay Module Schematic

## B. ESP8266 Wi-Fi Module

This system is a Wi-Fi microchip that is low cost having microcontroller capability and complete TCP/IP stack designed by Espressio Systems, China. The first time the chip got its attention was in August 2014 alongside the ESP-01 module, which the third-party manufacturer made – Ai-Thinker. With this small module, a Wi-Fi network can accept the connection of the microcontrollers and ordinary TCP/IP connections can be made with the use of Hayes-style

commands. In any case, in the first instance, no English language documentation was required on the chip as well as the accepted commands [15]. The scarcity of the components and its affordability are suggestions that it can finally be fully available in volumes, and then attracting numerous hackers to attempt to use the chip, accompanied software, and the module together, while using Chinese documentation or its translation. This system also has a built-in flash of 1 MiB, which permit for single-chip devices to connect directly to Wi-Fi connections [17].

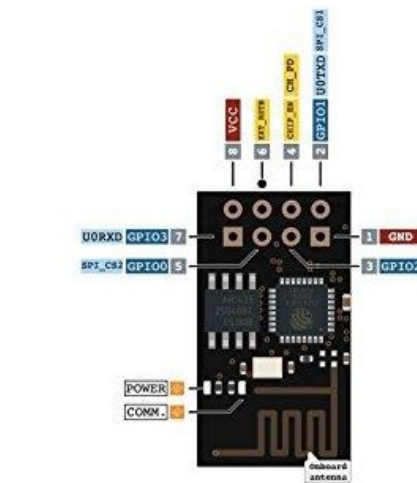

Figure 26 ESP8266 Wi-Fi Module

## C.

### 4.3 Subsystem 3: Power factor, Energy

After we were able to have both current and voltage readings in addition to the real power reading, we also became able to get the readings of power factor, energy, and voltage sensitivity as well through some coding in the library of Arduino.

#### A. Power Factor

The formula used is  $\cos(\theta_v - \theta_i)$ .

#### B. Energy

For the sake of presenting, we measured energy in kilo-watt-minutes instead of KWh, as KWh results are very small numbers considering the short time we have to present the demo. Energy is taken as the average every minute.

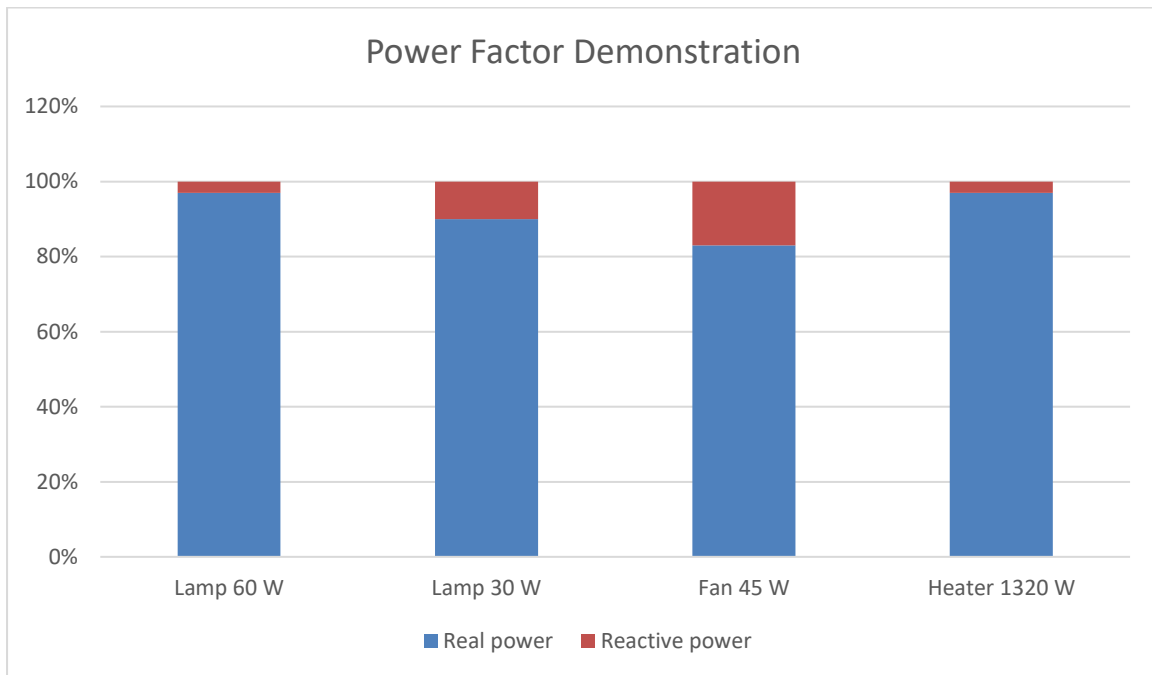

Figure 27 Real power to reactive power ratio (Power factor).

Table 2 Power factor, energy, and voltage-to-load sensitivity measurements.

Load	Power factor ( $\cos(\theta)$ )	Energy (KWmin)	Voltage to load Sensitivity $V(t)-V(t-u) / P(t)-P(t-u)$
Lamp 60 W	0.97	6.4	0.2
Lamp 30 W	0.92	5.2	0
Fan	0.83	5.6	0
Heater	0.97	115	2.3

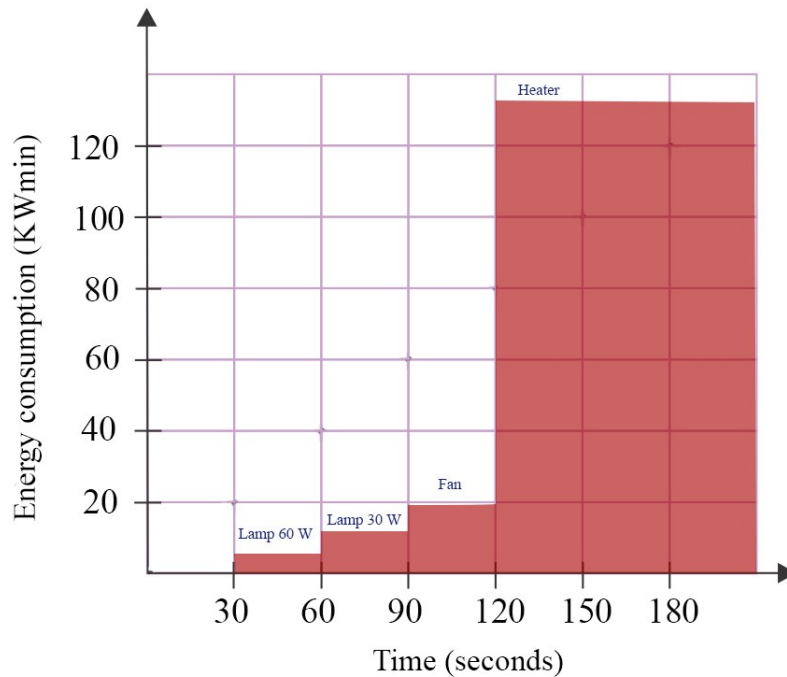

Figure 28 Energy consumption with all loads added up gradually.

### 4.3 Subsystem 4: Voltage to Load Sensitivity

#### A. Voltage to load Sensitivity

Voltage to Load Sensitivity is important because you can see how much you are far from the grid if the grid is far then the sensitivity is high thus the voltage will change dramatically if you plug in a huge load. If the grid is near then the sensitivity is low, therefore, there will not be much of a change in the voltage when plug in a huge load.

The sensitivity have many application to list few :

- \* Optimal battery placement
- \* Controlling renewables generation
- \* Controlling electric vehicles charging rate

It was measured using the simple formula  $[V(t)-V(t-u) / P(t)-P(t-u)]$ , where t is the time before the load is connected, and u is the time after the load is connected. Voltage sensitivity is measured every 30 seconds.

Table 3 Power factor, energy, and voltage-to-load sensitivity measurements.

Load	Power factor ( $\cos(\theta)$ )	Energy (KWmin)	Voltage to load Sensitivity $V(t)-V(t-u) / P(t)-P(t-u)$
Lamp 60 W	0.97	6.4	0.2
Lamp 30 W	0.92	5.2	0
Fan	0.83	5.6	0
Heater	0.97	115	2.3

### 4.3 Overall Results, Analysis and Discussion

The prototype of the proposed design is shown in Figure 24 while Figure 25 shows the inside view of the design. After powering on the meter, the measurement circuit current and voltage were observed by the sensors (current and voltage). The Arduino was used to compute the sensors' signals, adhering to the programmed algorithm. The data processed regarding power, voltage, and current showed results on the LCD display provided on the power meter. The connection of the single-phase power meter was done to the main supply prior to connecting the loads. The sensing of the voltage occurred after the neutral wire and live wire were connected to the system of the voltage sensor. The measurement of the voltage requires that just the live wire moved through the current sensor of the Hall Effect to get the current obtained by the load. The voltage sensor and current sensor of the analog signal were then converted directly to digital with the use of the ADC (analog to digital converter) embedded within the Arduino. The LCD display showed the results of the power ratings, applied voltage, and circuit current.



Figure 29 Prototype front view

For the proposed work, the factors measured were current, voltage, real power, active power, reactive power and energy consumption. All the measured values were cross checked with the known values using multi-meter. It has been observed that the proposed design is working well for the measured values of voltage, current and power. The design is embedded with the calibration of each module in Arduino. Any mismatch in the measured values were compensated for using the numerical values in Arduino Program.

The proposed smart energy meter was also tested for remote WiFi control. We had successfully demonstrated the ON/OFF operation of various appliances connected to the device. The mobile application was successfully integrated with hardware. It has been shown that the appliances can be controlled remotely with accuracy and exhibited good performance of the proposed device.

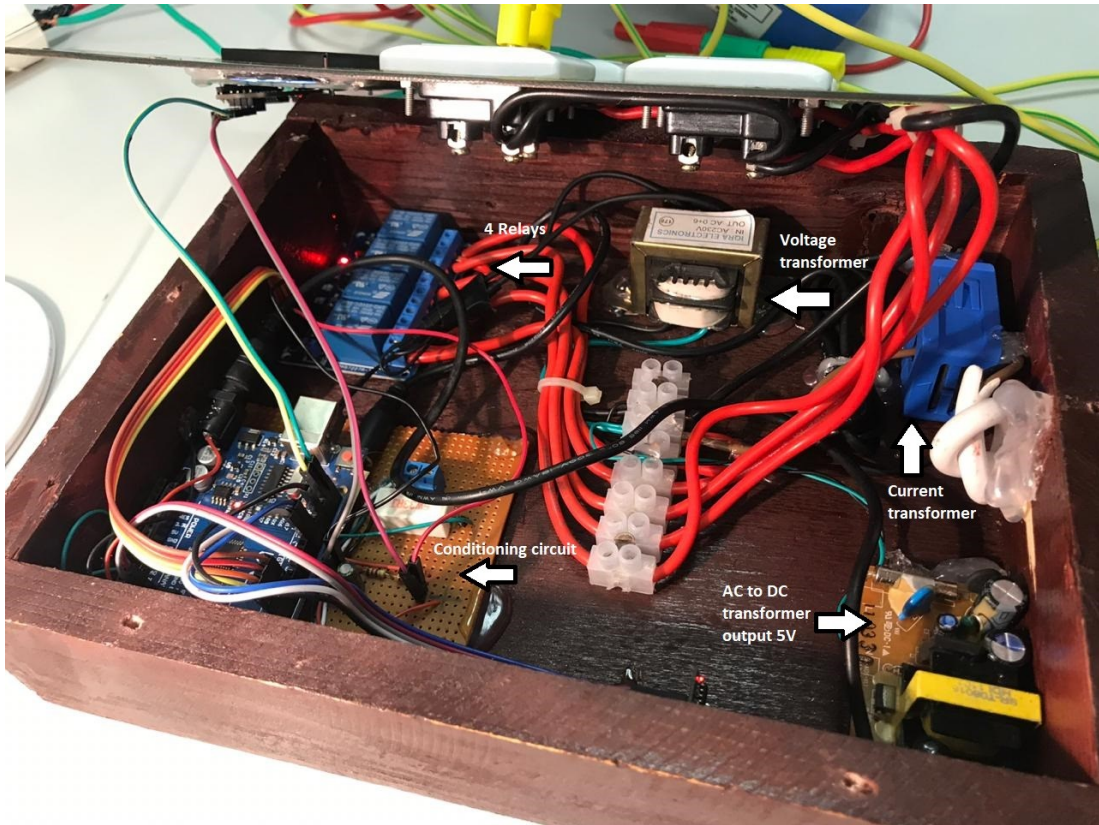

Figure 30 Prototype inside view

## 5. Project Management

### 5.1 Project Plan

The current high electricity tariff motivated us to contribute in the energy sector. The main objective was to come-up with a solution that would be suitable as well as beneficial for public. This proposed work can be extended further to be utilized for electricity consumers in the Kingdom of Saudi Arabia.

The proposed project work was divided into 4 sub-systems as given below.

1. Subsystem 1: Measuring Current and Voltage using CT and PT
2. Subsystem 2: Measurement of Power Factor
3. Subsystem 3: Power meter integration with software and hardware
4. Subsystem 4: Power meter integration with automated relay switching

The contribution of each group member to the implementation of each subsystem and time required to execute the project is given below:

Table 6: Contribution of all team members in sub-system implementation

Task	Mohammed	Abdullah	Ahmed	Khaled	Time Duration
Subsystem 1	30%	20%	35%	15%	4 weeks
Subsystem 2	25%	30%	20%	25%	2 weeks
Subsystem 3	30%	25%	15%	30%	8 weeks
Subsystem 4	25%	25%	20%	30%	5 weeks

## 5.2 Contribution of Team Members

SN	ACTIVITY	Assigned To	ACTUAL DURATION	PERCENT COMPLETE
1	Project Planning	M.D/KH/AE/AA	2	100%
2	subsystem 1: Power meter	M.D/KH	2	100%
3	Test subsystem: Power meter	M.D/KH	2	100%
4	Technical Theoretical Framework	M.D/KH/AE/AA	2	100%
5	Sensors Selection: Voltage and Current Sensor	M.D/KH	4	100%
6	Sensors Testing	M.D/KH	4	100%
7	Arduino Code Development	AE/AA	3	100%
8	Power factor code and Testing	AE/AA	2	100%
9	Relay selection and Relays testing on AC load	AE/AA	2	100%
11	Arduino Code Development for automated switching	AE/AA	2	100%
12	Prepare midterm Presentation	AE/AA	2	100%
13	Power factor code Development and Testing	M.D/AA	2	100%
14	Power Factor Accuracy Testing	M.D/AA	1	100%
15	Arduino Code Development for Relay Switching	M.D/AA	2	100%
16	subsystem: Energy and Sensitivity Analysis	M.D/AA		100%
17	Mobile App development for remote control	KH/AE		100%
18	Automated load switching testing	KH/AE		100%
19	System Level Integration and Testing	KH/AE		100%
20	Prepare final report	M.D/KH/AE/AA		100%
21	Prepare final presentation	M.D/KH/AE/AA		100%
22	Prepare Project Demo	M.D/KH/AE/AA		100%
23	Submit Rpt/PPT/Brochure ....	M.D/KH/AE/AA		100%

Table The contribution of each team member to perform the tasks are given in the below.

Table 7: Contribution of all team members

Task	Mohammed	Abdullah	Ahmed	Khaled	Task Total
Search & acquire components	30%	20%	35%	15%	100%
Design Subsystems	25%	30%	20%	25%	100%
Test Subsystems	30%	25%	15%	30%	100%
Write Reports & Presentations	25%	25%	20%	30%	100%

### 5.3 Project Execution Monitoring

In the proposed work, project execution was monitored since the inception of the idea till the execution and final demonstration of the full-scale project implementation. During the execution of the project, Team Leader Mr. Ahmed Al Enazi ensure the following:

- a. All the group members ensure that all stakeholders should be well informed about the progress and execution of the project.
- b. All the project stages were reviewed regularly by all team members.
- c. The project progress reports were regularly submitted to the Project Advisor.
- d. The project planning document was regularly updated based on the comments and feedback from the advisor and group members.
- e. We had ensured to meet regularly to discuss the progress of the project.
- f. All team members were regularly in contact and to-do lists was readily available to all team members.
- g. Validate and follow the schedule to ensure the start, finish and durations of all the tasks.
- h. We regularly validate the tasks and their relationship to the project plan execution.
- i. We had ensured to accomplish all the tasks accurately according to the plan.

- j. All the group members collaborated to conduct project status meetings regularly.
- k. Any delay due to the execution of the challenging tasks were tactfully executed.
- l. Any changes in the project execution planning was organized in a way to least impact to the schedule.
- m. All the team members were aware of any schedule change or updates that what had been done to resolve the problem.

#### 5.4 Challenges and Decision Making

During the implementation and the execution of the proposed work, we had faced a number of challenges that were overcome with time. The list of all these challenges are outlined below:

- Feasibility study of the project execution
- Component selection stage to choose the best available resources
- Availability of component in local market
- Potential high risk while working with 220V AC main
- Analysis of the accuracy of voltage sensor and current sensor
- The calibration of voltage sensor
- Calibration of current sensor
- The calculation of power factor and its accuracy determination was a one of greatest challenge we face during the execution of this project work

Table 8 List of used component and prices

	Component Used	Price (SAR)
1	Arduino Uno	100
2	LCD 20 x 4	150
3	ESP8266 Wi-Fi Module	100
4	4-Channel Relay Module	75
5	Current Transformer SCT-013	60
6	Step-Down 220v -12V Transformer	50
7	Resistor 0.33k Ohms 5Watt	2
8	Connectors	10
9	Jumper Wires	5
10	Sockets	30
11	Plug	2
12	Electric Board	150
13	Electric Wire	20

14	Resistor 10K Ohms	5
15	Resistor 100K Ohms	5
16	220VAC – 5VDC Power Supply	40
17	I2C Protocol Module For LCD	45
Total		894

- Relay automated switching and its integration with mobile application

### **5.5 Project Bill of Materials and Budget**

The list of the used components and the prices of the selected components are given in the below table.

## **6. Project Analysis**

### **6.1 Life-long Learning**

Practical work experience and training during the execution of senior design project execution for graduating students is their first step to professional career to develop practical work experiences and enhance their skills. Therefore, this was an ideal opportunity for us that enable to get exposure and prepare ourselves for the research and development jobs for the challenging future employment. During the practical project development work experience, we had developed excellent working skills, polished our communication skills and develop strategies to work in a team.

In this project, we have learnt a lot independently. The experience gained by implementing a new technologies and work with different kind of sensors was a great addition to our

professional skills set. Following are the skills set that we have learnt during the execution of this project:

1. Get familiar with Arduino IDE software and coding
2. Learn many Arduino libraries that helped us in practical system implementation
3. Sensor interfacing with microcontroller
4. Learn about how to test the complete systems
5. Learn about the system level integration
6. Develop Project management skills
7. Time management skills
8. Report writing
9. Hardware assembling

## **6.2 Impact of Engineering Solutions**

Engineering solutions always have some impact on the people and society for their benefits. The engineering solution devised in this project work has a positive impact on the society. In this project, the solution provided will impact the electricity consumers in a very positive way. The impact of the proposed engineering solution on people's life and society are highlighted below:

- a. The design evaluate and describe accurately the impact of increasing tariff of electricity on people, its effects on the middle class income families.
- b. The smart energy metering system will help the electricity consumers to save energy usage.
- c. The switching mechanism is easy to be implemented.
- d. The remote control sensing will enable the users to control the electricity consumption.
- e. The consumer behavior can be enhanced by adopting the smart energy metering and controlling the energy consumption.
- f. This project accurately determine the energy usage and enable consumers to be updated on the energy consumption.
- g. Evaluate and describe accurately the economic tradeoffs of the proposed work in newly constructed residential areas.

## **6.3 Contemporary Issues Addressed**

The existing conventional metering system requires to send the meter readings to electric power companies for real time billing purposes. The conventional methods is unable to control

the power losses at the residential and commercial premises. The metering system is unable to accurately determine the energy usage and solely depends on manual readings. The contemporary issues as addressed in the proposed design are highlighted below:

- a. The smart energy metering system can be utilized to reduce the laborious work of manual energy consumption reading.
- b. Digitally measure consumption of electricity by measuring current, voltage, power factor and energy usage.
- c. The system enable to check the energy usage at any given time.
- d. A mobile application is developed to remotely communicate with the Main Control Energy system.
- e. WiFi enabled appliances/load control switching control system
- f. Apply control measures to reduce consumption
- g. Control all appliances remotely to save energy

## **7. Conclusions and Future Recommendations**

### **7.1 Conclusions**

In this project, a smart energy meter system is designed and built using Arduino UNO microcontroller with current and voltage sensors. The measured energy is displayed on the 20 x 4 Lcd using I2C modules. The smart meter is used to replace the mechanical energy meter that has several advantages over the mechanical one. In addition, smart meter has the ability to give us the voltage and current reading at the given instance of time. In addition, we can use the smart meter for producing reading of various electrical quantities processed in Arduino microcontroller. The proposed device can be utilized to measure the amount of electric power consumed by electrical appliances along with the monitoring and the consumption of electric energy usage by measuring both current and voltage signal from power system. Voltage and current signal are sampled and analyzed by using Arduino. The devices is embedded with WiFi control switching operation, i.e- to turn on/off the appliances at any time remotely. An Arduino code is developed to measure the various circuit parameters including current voltage, power factor (PF) real power consumption and reactive power. The system is also embedded with sensitivity measurement module and the values are displayed regularly. To control the various

appliances, a mobile application is developed and integrated with the system. WiFi enabled energy metering system can be utilized to control the appliances remotely.

## **7.2 Future Recommendations**

For future work, we suggest expanding the smart meter to work with three-phase system and to replace the display module with another has the ability to display the results as a graphics form. Following changes are recommended to be implemented in this project to make it more accurate and reliable.

- Three-Phase measuring
- Graphical display
- Increase LCD size
- Increase current rating of system up to 100A.
- More compact size

## References

- [1]. Lee, Shi-Wei, et al. "Design of an automatic meter reading system [electricity metering]." Proceedings of the 1996 IEEE IECON. 22nd International Conference on Industrial Electronics, Control, and Instrumentation. Vol. 1. IEEE, 1996.
- [2]. Popa, M. "Data collecting from smart meters in an Advanced Metering Infrastructure." 2011 15th IEEE International Conference on Intelligent Engineering Systems. IEEE, 2011.
- [3]. Rashdi, Adnan, et al. "Remote energy monitoring, profiling and control through GSM network." Arabian Journal for Science and Engineering 38.11 (2013): 3249-3257.
- [4]. Abdollahi, Ali, Marjan Dehghani, and Negar Zamanzadeh. "SMS-based reconfigurable automatic meter reading system." 2007 IEEE International Conference on Control Applications. IEEE, 2007.
- [5]. Sehgal, Vivek Kumar, et al. "Electronic Energy Meter with instant billing." 2010 Fourth UKSim European Symposium on Computer Modeling and Simulation. IEEE, 2010.
- [6] Anon: "Electricity Tariff Fundamentals", University of Pretoria Electricity and Energy group, 2008. [Online]. Available e-mail: Werner.Badenhorst@up.ac.za Message: get Electrical Tariff Fundamentals paper
- [8]Anon: "Retail Tariff Restructuring Plan", www.eskom.co.za, 2008. [Online]. Available: [http://www.eskom.co.za/live/content.php?Category\\_ID=287](http://www.eskom.co.za/live/content.php?Category_ID=287)
- [9] Ryan Firestone, Chris Marnay: "The Effects of Electricity Tariff Structure on Distributed Generation Adoption in New York State", Environmental Energy Technologies Division, 2005. [Online]. Available: <http://eetd.lbl.gov/EA/EMP/>
- [10] Dr. C. Cooper, J. Prinsloo: "Digest of South African energy statistics", Department of Minerals and Energy (South Africa), 2005. [Online]. Available: [www.dme.gov.za/pdfs/energy/planning/digest\\_energy\\_05.pdf](http://www.dme.gov.za/pdfs/energy/planning/digest_energy_05.pdf)
- [11] Hubert D. Henderson: "Supply and Demand", EBook #10612, 2004. [Online]. Available: <http://www.gutenberg.org/ebooks/10612>
- [12] Department of Minerals and Energy: "National Response To South Africa's Electricity Shortage", Interventions to address electricity shortages, 2008. [Online]. Available: [www.info.gov.za/otherdocs/2008/nationalresponse\\_sa\\_electricity1.pdf](http://www.info.gov.za/otherdocs/2008/nationalresponse_sa_electricity1.pdf)
- [13] David S. Loughran, Jonathan Kulick: "Demand-Side Management and Energy Efficiency in the United States", The Energy Journal, Vol. 25, No. 1, 2004.

- [14] David Harper: “Understanding Supply-Side Economics”, [www.investopedia.com](http://www.investopedia.com), 2008. [Online]. Available: <http://www.investopedia.com/articles/05/011805.asp>
- [15] Rob Hartway, Snuller Price, C.K. Woo: “Smart meter, customer choice and profitable time-of-use rate option”, *Energy* 24, 1999, pp.895–903
- [16] M.E. Phillips, B.J. Adams: “Transforming the Ferraris Disc Meter into a key element in an automated meter reading system”, *Metering and Tariffs for Energy Supply*, 3-5July 1996, Conference Publication No. 426, OIEE, 1996.
- [17] Anon: “Radio Teleswitching”, *Radio Teleswitching Services*, 2008. [Online]. Available: <http://www.energynetworks.org/rts/>

# Appendix A: Progress Reports

## Progress Report 01

Title: Smart Energy Meter		Advisor: Mr Saifullah Shafiq		Design II (ASSE 3)		Spring 2019												
Mohammed AL-Dhameri 201303744				Project PLAN & Progress														
Khalid AL-Etaiby 201500251				ProgRpt No. 1														
Ahmed AL-Enazi 201501178				Plan updated (Date): 25 January 2019														
Abdullah Abaoud 201402809				Instructor: Dr. Chedly B. Yahya														
				Period Highlight: 4		Actual												
				Actual (beyond plan)		% Complete (beyond plan)												
				Periods (Weeks 1-15)														
				1	2	3	4	5	6	7	8	9	10	11	12	13	14	15
Project Planning	1	1	M.D/KH/AE/AA	2	2	100%												
Design subsystem 1: Powermeter	2	1	M.D/KH	2	2	35%												
Test subsystem: Powermeter	2	1	M.D/KH	2	2	20%												
Technical Theoretical Framework	3	2	M.D/KH/AE/AA	3	2	60%												
Sensors Selection: Voltage and Current Sensor	3	3	M.D/KH	3	4	65%												
Sensors Testing	4	3	M.D/KH	4	4	0%												
Arduino Code Development	5	4	AE/AA			0%												
Relay selection for automated operation	5	2	AE/AA			0%												
Relays testing on AC load	5	2	AE/AA			0%												
Arduino Code Development for automated switching	6	5	AE/AA			0%												
Automated switching testing	6	1	AE/AA			0%												
Prepare midterm Presentation	7	3	M.D/AA			0%												
System Integration: Powermeter with AC loads	8	2	M.D/AA			0%												
Integrated system testing and measurements	9	3	M.D/AA			0%												
Design subsystem: Energymeter and Sensitivity Analysis	9	4	M.D/AA			0%												
Sensitivity Analysis and its application	10	2	KH/AE			0%												
Sensitivity Analysis: Application	10	1	KH/AE			0%												
Sensitivity Analysis system level testing	11	2	KH/AE			0%												
Prepape final report	12	2	M.D/KH/AE/AA			0%												
Prepape final presentation	12	2	M.D/KH/AE/AA			0%												
Prepare Project Demo	13	3	M.D/KH/AE/AA			0%												
Submit Rpt/PPT/Brochure ....	14	2	M.D/KH/AE/AA			0%												
<b>Progress Details:</b>								<b>Issues (delay ...):</b>										

## Progress Report 02

Title: Smart Energy Meter		Advisor: Mr Saifullah Shafiq		Design II (ASSE 3)		Spring 2019												
Mohammed AL-Dhameri 201303744				Project PLAN & Progress														
Khalid AL-Etaiby 201500251				ProgRpt No. 2														
Ahmed AL-Enazi 201501178				Plan updated (Date): Feb 3, 2019														
Abdullah Abaoud 201402809				Instructor: Dr. Chedly B. Yahya														
				Period Highlight: 4		Actual												
				Actual (beyond plan)		% Complete (beyond plan)												
				Periods (Weeks 1-15)														
				1	2	3	4	5	6	7	8	9	10	11	12	13	14	15
Project Planning	1	1	M.D/KH/AE/AA	2	2	100%												
Design subsystem 1: Powermeter	2	1	M.D/KH	2	2	35%												
Test subsystem: Powermeter	2	1	M.D/KH	2	2	20%												
Technical Theoretical Framework	3	2	M.D/KH/AE/AA	3	2	60%												
Sensors Selection: Voltage and Current Sensor	3	3	M.D/KH	3	4	65%												
Sensors Testing	4	3	M.D/KH	4	4	70%												
Arduino Code Development	5	4	AE/AA	3	3	50%												
Power factor code and Testing	5	2	AE/AA	2	2	80%												
Relay selection and Relays testing on AC load	5	2	AE/AA	2	2	10%												
Arduino Code Development for automated switching	6	5	AE/AA	2	2	15%												
Automated switching testing	6	1	AE/AA			0%												
Prepare midterm Presentation	7	3	M.D/AA			0%												
System Integration: Powermeter with AC loads	8	2	M.D/AA			0%												
Integrated system testing and measurements	9	3	M.D/AA			0%												
Design subsystem: Energymeter and Sensitivity Analysis	9	4	M.D/AA			0%												
Sensitivity Analysis and its application	10	2	KH/AE			0%												
Sensitivity Analysis: Application	10	1	KH/AE			0%												
Sensitivity Analysis system level testing	11	2	KH/AE			0%												
Prepape final report	12	2	M.D/KH/AE/AA			0%												
Prepape final presentation	12	2	M.D/KH/AE/AA			0%												
Prepare Project Demo	13	3	M.D/KH/AE/AA			0%												
Submit Rpt/PPT/Brochure ....	14	2	M.D/KH/AE/AA			0%												
<b>Progress Details:</b>				Last week, we have demonstrated the powermeter successfully. The current and voltage accuracy was tested and verified. Next phase of the project, we are working on calculating the power factor (pF). Different approaches have been investigated. Working on the accurate measurement of pF for various type of loads.				<b>Issues (delay ...):</b>				We are on track and will be able to demonstrate our final work on time.						

### Progress Report 03

Title: Smart Energy Meter		Advisor: Mr Saifullah Shafiq		Design II (ASSE 3)			Spring 2019														
Mohammed AL-Dhameri 201303744				Project PLAN & Progress																	
Khalid AL-Etaiby 201500251				ProgRpt No. 3																	
Ahmed AL-Enazi 201501178				Plan updated (Date): March 01, 2019																	
Abdullah Abaoud 201402809				Instructor: Dr. Chedly B. Yahya																	
				Period Highlight:		4		Plan		Actual											
				Actual (beyond plan)				% Complete (beyond plan)													
ACTIVITY							Periods (Weeks 1-15)														
PLAN START	PLAN DURATION	Assigned To	ACTUAL START	ACTUAL DURATION	PERCENT COMPLETE																
1	1	M.D/KH/AE/AA	2	2	100%	[Gantt chart bars]															
2	1	M.D/KH	2	2	100%	[Gantt chart bars]															
2	1	M.D/KH	2	2	100%	[Gantt chart bars]															
3	2	M.D/KH/AE/AA	3	2	100%	[Gantt chart bars]															
3	3	M.D/KH	3	4	100%	[Gantt chart bars]															
4	3	M.D/KH	4	4	100%	[Gantt chart bars]															
5	4	AE/AA	3	3	100%	[Gantt chart bars]															
5	2	AE/AA	2	2	80%	[Gantt chart bars]															
5	2	AE/AA	2	2	70%	[Gantt chart bars]															
6	5	AE/AA	2	2	60%	[Gantt chart bars]															
6	1	AE/AA	2	2	50%	[Gantt chart bars]															
7	3	M.D/AA	2	2	40%	[Gantt chart bars]															
8	2	M.D/AA	1	1	30%	[Gantt chart bars]															
9	3	M.D/AA	2	2	10%	[Gantt chart bars]															
9	4	M.D/AA			10%	[Gantt chart bars]															
10	2	KH/AE			0%	[Gantt chart bars]															
10	1	KH/AE			0%	[Gantt chart bars]															
11	2	KH/AE			0%	[Gantt chart bars]															
12	2	M.D/KH/AE/AA			0%	[Gantt chart bars]															
12	2	M.D/KH/AE/AA			0%	[Gantt chart bars]															
13	3	M.D/KH/AE/AA			0%	[Gantt chart bars]															
14	2	M.D/KH/AE/AA			0%	[Gantt chart bars]															

**Progress Details:**  
Last week, we have successfully completed the power factor (pF) implementation. Various AC loads were tested and good accuracy in results is achieved.

**Issues (delay ...):**  
We are on track and will be able to demonstrate our final work on time.

### Progress Report 04

ACTIVITY		PLAN START	PLAN DURATION	Assigned To	ACTUAL START	ACTUAL DURATION	PERCENT COMPLETE	Actual (beyond plan) % Complete (beyond plan)														
							Periods (Weeks 1-15)															
							1	2	3	4	5	6	7	8	9	10	11	12	13	14	15	
1	Project Planning	1	1	M.D/KH/AE/AA	2	2	100%	[Gantt chart bars]														
2	Design subsystem 1: Powermeter	2	1	M.D/KH	2	2	100%	[Gantt chart bars]														
2	Test subsystem: Powermeter	2	1	M.D/KH	2	2	100%	[Gantt chart bars]														
3	Technical Theoretical Framework	3	2	M.D/KH/AE/AA	3	2	100%	[Gantt chart bars]														
3	Sensors Selection: Voltage and Current Sensor	3	3	M.D/KH	3	4	100%	[Gantt chart bars]														
4	Sensors Testing	4	3	M.D/KH	4	4	100%	[Gantt chart bars]														
5	Arduino Code Development	5	4	AE/AA	5	5	100%	[Gantt chart bars]														
5	Power factor code and Testing	5	2	AE/AA	8	1	100%	[Gantt chart bars]														
5	Relay selection and Relays testing on AC load	5	2	AE/AA			0%	[Gantt chart bars]														
6	Arduino Code Development for automated switchin	6	5	AE/AA			0%	[Gantt chart bars]														
6	Prepare midterm Presentation	6	1	AE/AA	6	2	100%	[Gantt chart bars]														
7	Power factor code Development and Testing	7	3	M.D/AA	7	2	100%	[Gantt chart bars]														
8	Power Factor Accuracy Testing	8	2	M.D/AA	8	1	100%	[Gantt chart bars]														
9	Arduino Code Development for Relay Switching	9	3	M.D/AA	7	1	80%	[Gantt chart bars]														
9	Design subsystem: Energymeter and Sensitivity Ana	9	4	M.D/AA			80%	[Gantt chart bars]														
10	Mobile App development for remote control	10	2	KH/AE			50%	[Gantt chart bars]														
10	Automated load switching testing	10	1	KH/AE			0%	[Gantt chart bars]														
11	System Level Integration and Testing	11	2	KH/AE			0%	[Gantt chart bars]														
12	Prepapre final report	12	2	M.D/KH/AE/AA			0%	[Gantt chart bars]														
12	Prepapre final presentation	12	2	M.D/KH/AE/AA			0%	[Gantt chart bars]														
13	Prepare Project Demo	13	3	M.D/KH/AE/AA			0%	[Gantt chart bars]														
14	Submit Rpt/PPT/Brochure ....	14	2	M.D/KH/AE/AA			0%	[Gantt chart bars]														

### Progress Report 05



15	Resistor 100K Ohms	5
16	220VAC – 5VDC Power Supply	40
17	I2C Protocol Module For LCD	45

# Appendix C: Datasheet

## Arduino Uno



Arduino Uno R3 Front

Arduino Uno R3 Back



Arduino Uno R2 Front

Arduino Uno SMD

Arduino Uno Front

Arduino Uno Back

## Overview

The Arduino Uno is a microcontroller board based on the ATmega328 ([datasheet](#)). It has 14 digital input/output pins (of which 6 can be used as PWM outputs), 6 analog inputs, a 16 MHz ceramic resonator, a USB connection, a power jack, an ICSP header, and a reset button. It contains everything needed to support the microcontroller; simply connect it to a computer with a USB cable or power it with a AC-to-DC adapter or battery to get started.

The Uno differs from all preceding boards in that it does not use the FTDI USB-to-serial driver chip. Instead, it features the Atmega16U2 (Atmega8U2 up to version R2) programmed as a USB-to-serial converter.

[Revision 2](#) of the Uno board has a resistor pulling the 8U2 HWB line to ground, making it easier to put into DFU mode.

[Revision 3](#) of the board has the following new features:

- 1.0 pinout: added SDA and SCL pins that are near to the AREF pin and two other new pins placed near to the RESET pin, the IOREF that allow the shields to adapt to the voltage provided from the board. In future, shields will be compatible both with the board that use the AVR, which operate with 5V and with the Arduino Due that operate with 3.3V. The second one is a not connected pin, that is reserved for future purposes.
- Stronger RESET circuit.
- Atmega 16U2 replace the 8U2.

"Uno" means one in Italian and is named to mark the upcoming release of Arduino 1.0. The Uno and version 1.0 will be the reference versions of Arduino, moving forward. The Uno is the latest in a series of USB Arduino boards, and the reference model for the Arduino platform; for a comparison with previous versions, see the [index of Arduino boards](#).

## Summary

Microcontroller	ATmega328
Operating Voltage	5V
Input Voltage (recommended)	7-12V

Model: SCT-013

Rated input current: 5A/100A

Characteristics: Opening size: 13mm\*13mm,  
 Non-linearity±3% (10%—120% of rated input current)  
 1m leading wire, standard Φ3.5 three core plug output.  
 Current output type and voltage output type (voltage output type built-in sampling resistor)

Purpose: Used for current measurement, monitor and protection for AC motor, lighting equipment, air compressor etc

Core material: ferrite

Mechanical strength: the number of switching is not less than 1000 times(test at 25℃)

Safety index: Dielectric strength(between shell and output)1000V AC/1min

Fire resistance property: In accordance with UL94-Vo

Work temperature: -25℃~+70℃



Outline size diagram: (in mm)

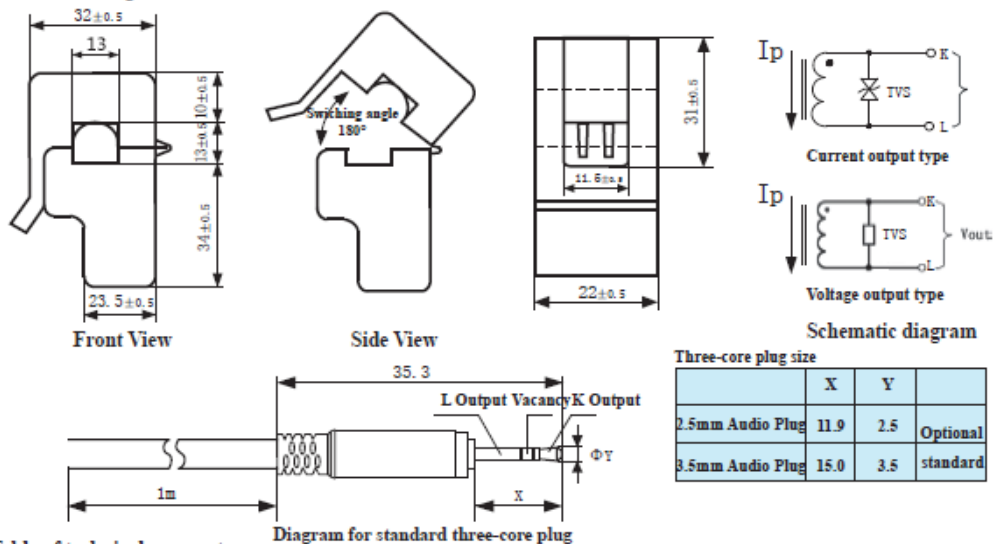

Three-core plug size

	X	Y	
2.5mm Audio Plug	11.9	2.5	Optional
3.5mm Audio Plug	15.0	3.5	standard

Table of technical parameter:

Model	SCT-013-000	SCT-013-005	SCT-013-010	SCT-013-015	SCT-013-020
Input current	0-100A	0-5A	0-10A	0-15A	0-20A
Output type	0-50mA	0-1V	0-1V	0-1V	0-1V
Model	SCT-013-025	SCT-013-030	SCT-013-050	SCT-013-060	SCT-013-000V
Input current	0-25A	0-30A	0-50A	0-60A	0-100A
Output type	0-1V	0-1V	0-1V	0-1V	0-1V

※ Output type: voltage output type built-in sampling resistor, current output type built-in protective diode.

Tel: 86-13933609279 Fax: 86-7929499-804 skype:macymengl  
 Web (China): www.yhdc.com Web (Latvia): www.yhdc.lv



## User Guide

### 4 Channel 5V Optical Isolated Relay Module

This is a LOW Level 5V 4-channel relay interface board, and each channel needs a 15-20mA driver current. It can be used to control various appliances and equipment with large current. It is equipped with high-current relays that work under AC250V 10A or DC30V 10A. It has a standard interface that can be controlled directly by microcontroller. This module is optically isolated from high voltage side for safety requirement and also prevent ground loop when interface to microcontroller.



#### Brief Data:

- Relay Maximum output: DC 30V/10A, AC 250V/10A.
- 4 Channel Relay Module with Opto-coupler. LOW Level Trigger expansion board, which is compatible with Arduino control board.
- Standard interface that can be controlled directly by microcontroller ( 8051, AVR, \*PIC, DSP, ARM, ARM, MSP430, TTL logic).
- Relay of high quality low noise relays SPDT. A common terminal, a normally open, one normally closed terminal.
- Opto-Coupler isolation, for high voltage safety and prevent ground loop with microcontroller.

## 20 x 4 Character LCD

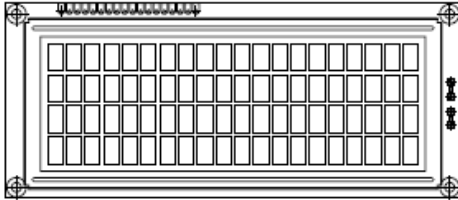

### FEATURES

- Type: Character
- Display format: 20 x 4 characters
- Built-in controller: ST 7066 (or equivalent)
- Duty cycle: 1/16
- 5 x 8 dots includes cursor
- + 5 V power supply (also available for + 3 V)
- LED can be driven by pin 1, pin 2, pin 15, pin 16 or A and K
- N.V. optional for + 3 V power supply
- Material categorization: For definitions of compliance please see [www.vishay.com/doc?99912](http://www.vishay.com/doc?99912)

**RoHS  
COMPLIANT**

MECHANICAL DATA		
ITEM	STANDARD VALUE	UNIT
Module Dimension	146.0 x 62.5	mm
Viewing Area	123.5 x 43.0	
Dot Size	0.92 x 1.10	
Dot Pitch	0.98 x 1.16	
Mounting Hole	139.0 x 55.5	
Character Size	4.84 x 9.22	

ABSOLUTE MAXIMUM RATINGS					
ITEM	SYMBOL	STANDARD VALUE			UNIT
		MIN.	TYP.	MAX.	
Power Supply	$V_{DD}$ to $V_{SS}$	- 0.3	-	7.0	V
Input Voltage	$V_I$	- 0.3	-	$V_{DD}$	

**Note**

- $V_{SS} = 0$  V,  $V_{DD} = 5.0$  V

ELECTRICAL CHARACTERISTICS						
ITEM	SYMBOL	CONDITION	STANDARD VALUE			UNIT
			MIN.	TYP.	MAX.	
Input Voltage	$V_{DD}$	$V_{DD} = +5$ V	4.7	5.0	5.3	V
		$V_{DD} = +3$ V	2.7	3.0	5.3	
Supply Current	$I_{DD}$	$V_{DD} = +5$ V	-	8.0	10.0	mA
Recommended LC Driving Voltage for Normal Temperature Version Module	$V_{DD}$ to $V_O$	- 20 °C	5.0	5.1	5.7	V
		0 °C	4.6	4.8	5.2	
		25 °C	4.1	4.5	4.7	
		50 °C	3.9	4.2	4.5	
		70 °C	3.7	3.9	4.3	
LED Forward Voltage	$V_F$	25 °C	-	4.2	4.6	V
LED Forward Current	$I_F$	25 °C	-	540	1080	mA
EL Power Supply Current	$I_{EL}$	$V_{EL} = 110$ V <sub>AC</sub> , 400 Hz	-	-	5.0	mA

OPTIONS									
TN	PROCESS COLOR					BACKLIGHT			
	STN Gray	STN Yellow	STN Blue	FSTN B&W	STN Color	None	LED	EL	CCFL
x	x	x	x	x		x	x	x	

For detailed information, please see the "Product Numbering System" document.

DISPLAY CHARACTER ADDRESS CODE																				
Display Position																				
	1	2	3	4	5	6	7	8	9	10	11	12	13	14	15	16	17	18	19	20
DD RAM Address	00	01	02	03	04	05	06	07	08	09	0A	0B	0C	0D	0E	0F	10	11	12	13
DD RAM Address	40	41	42	43	44	45	46	47	48	49	4A	4B	4C	4D	4E	4F	50	51	52	53
DD RAM Address	14	15	16	17	18	19	1A	1B	1C	1D	1E	1F	20	21	22	23	24	25	26	27
DD RAM Address	54	55	56	57	58	59	5A	5B	5C	5D	5E	5F	60	61	62	63	64	65	66	67

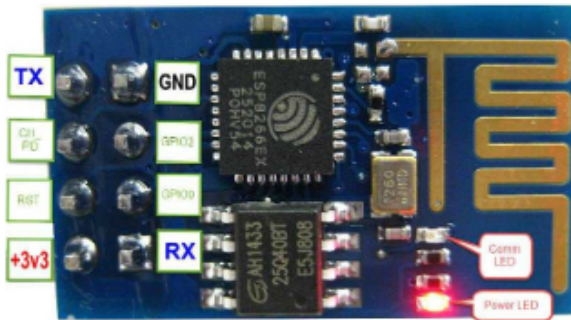

## ESP8266 Datasheet

P. MARIAN



ESP8266 IC datasheet

ESP8266 offers a complete and self-contained Wi-Fi networking solution, allowing it to either host the application or to offload all Wi-Fi networking functions from another application processor.



When ESP8266 hosts the application, and when it is the only application processor in the device, it is able to boot up directly from an external flash. It has integrated cache to improve the performance of the system in such applications, and to minimize the memory requirements.

Alternately, serving as a Wi-Fi adapter, wireless internet access can be added to any microcontroller-based design with simple connectivity through UART interface or the CPU AHB bridge interface.

[download ESP8266 datasheet pdf](#)

### ESP8266 Features

- 802.11 b/g/n protocol
- Wi-Fi Direct (P2P), soft-AP
- Integrated TCP/IP protocol stack
- Integrated TR switch, balun, LNA, power amplifier and matching network
- Integrated PLL, regulators, and power management units
- +19.5dBm output power in 802.11b mode
- Integrated temperature sensor
- Supports antenna diversity
- Power down leakage current of < 10uA
- Integrated low power 32-bit CPU could be used as application processor
- SDIO 2.0, SPI, UART
- STBC, 1×1 MIMO, 2×1 MIMO
- A-MPDU & A-MSDU aggregation & 0.4µs guard interval
- Wake up and transmit packets in < 2ms
- Standby power consumption of < 1.0mW (DTIM3)

## Appendix D: Program Code

```
#include <LiquidCrystal_I2C.h>
#include <SoftwareSerial.h>
#include "EmonLib.h"

EnergyMonitor CurrentVoltageSensor; //
Initiliaze Current & Voltage Library
SoftwareSerial ESP8266(11, 12); //
Initiliaze Software Serial RX, TX
LiquidCrystal_I2C lcd(0x3F, 2, 1, 0, 4, 5, 6, 7, 3, POSITIVE); //
Initiliaze LCD

//*****ESP8266 Variables*****//
String server = ""; //variable for sending data to webpage
boolean No_IP = false; //variable to check for ip Address
String IP = ""; //variable to store ip Address
char temp1 = '0'; // Temparary Variable for Status
int a = 0; //Loop Variable
String ESP_STRING = ""; //variable to store ESP String

//*****Current & Voltages*****//
float Current; // Variable for Current
float Voltages; // Variable for Voltages
float Power_Factor; // Variable for Power_Factor
float Real_Power; // Variable for Real_Power
float Reactive_Power; // Variable for Reactive_Power
float Units; // Variable for Unit
float v1 = 0; // Previous Voltage Variable
float v2 = 0; // Final Voltage Variable
float p1 = 0; // Previous Power Variable
float p2 = 0; // Final Power Variable
double Sensi; // Sensitivity Variable
int x = 0; // Variable for counting and make difference b/w
previous value and final value

void setup()
{
  lcd.begin(20, 4); // LCD Dimenssions Set 20x4
  Serial.begin(9600); // Serial Monitor Baud Rate Set 9600
  ESP8266.begin(9600); // Wifi Module Baud Rate Set 9600

  CurrentVoltageSensor.voltage(0, 330, 5.5); // Voltage: input pin,
  calibration, phase_shift
  CurrentVoltageSensor.current(2, 100); // Current: input pin,
  calibration.

  pinMode(3 , OUTPUT); // Set PinMode Of Switch 1
  pinMode(4 , OUTPUT); // Set PinMode Of Switch 2
  pinMode(5 , OUTPUT); // Set PinMode Of Switch 3
  pinMode(6 , OUTPUT); // Set PinMode Of Switch 4
}
```

```

digitalWrite(3, LOW); // Switch 1 Relay Off
digitalWrite(4, HIGH); // Switch 2 Relay Off
digitalWrite(5, HIGH); // Switch 3 Relay Off
digitalWrite(6, HIGH); // Switch 4 Relay Off

lcd.clear(); //Clear Lcd Screen
lcd.setCursor(0, 0); //Set Cursor on 0x0 Position
lcd.print(" SMART ENERGY METER "); //Print String on LCD

lcd.setCursor(0, 2);
lcd.print("Connecting to WIFI..");

wifi_init(); //Call Wifi Initialize UDF for
connecting to router
showIP(); //Call IP Address UDF for getting IP

lcd.setCursor(0 , 2);
lcd.print("IP:");
lcd.print(IP);
lcd.setCursor(0 , 3);
lcd.print("Port: 80");
delay(5000); //Delay 5 Seconds
}

void loop()
{
  x++;
  MeasureValues(); // Call this UDF for Measure Recent Values of all
Parameters
  PrintValues(); // Call this Udf to Print Values on LCD

  while (ESP8266.available()) // If Wifi module Connected with
Mobile App
  {
    ESP_STRING = ESP8266.readString(); // ESP8266 Read Serial Data From
Mobile App
    Serial.println(ESP_STRING);

    if (ESP_STRING.endsWith("r1on") || ESP_STRING.endsWith("switch one on")
|| ESP_STRING.endsWith("switch 1 on") )
    {
      digitalWrite(3, LOW);
      lcd.clear();
      lcd.setCursor(0, 2);
      lcd.print(" Switch 1 ON ");
      delay(1000);
    }

    else if (ESP_STRING.endsWith("r2on") || ESP_STRING.endsWith("switch two
on") || ESP_STRING.endsWith("switch 2 on"))
    {
      digitalWrite(4, LOW);
      lcd.clear();
      lcd.setCursor(0, 2);
      lcd.print(" Switch 2 ON ");
      delay(1000);
    }

    else if (ESP_STRING.endsWith("r3on") || ESP_STRING.endsWith("switch
three on") || ESP_STRING.endsWith("switch 3 on") )

```

```

    {
        digitalWrite(5, LOW);
        lcd.clear();
        lcd.setCursor(0, 2);
        lcd.print("      Switch 3 ON      ");
        delay(1000);
    }
    else if (ESP_STRING.endsWith("r4on") || ESP_STRING.endsWith("switch
four on") || ESP_STRING.endsWith("switch 4 on"))
    {
        digitalWrite(6, LOW);
        lcd.clear();
        lcd.setCursor(0, 2);
        lcd.print("      Switch 4 ON      ");
        delay(1000);
    }
    else if (ESP_STRING.endsWith("allon") || ESP_STRING.endsWith("all on")
|| ESP_STRING.endsWith("All on"))
    {
        digitalWrite(3, LOW);
        digitalWrite(4, LOW);
        digitalWrite(5, LOW);
        digitalWrite(6, LOW);
        lcd.clear();
        lcd.setCursor(0, 2);
        lcd.print("  All Switches ON  ");
        delay(1000);
    }
    else if (ESP_STRING.endsWith("r1loff") || ESP_STRING.endsWith("switch
one off") || ESP_STRING.endsWith("switch 1 off"))
    {
        digitalWrite(3, HIGH);
        lcd.clear();
        lcd.setCursor(0, 2);
        lcd.print("      Switch 1 OFF      ");
        delay(1000);
    }
    else if (ESP_STRING.endsWith("r2off") || ESP_STRING.endsWith("switch
two off") || ESP_STRING.endsWith("switch 2 off"))
    {
        digitalWrite(4, HIGH);
        lcd.clear();
        lcd.setCursor(0, 2);
        lcd.print("      Switch 2 OFF      ");
        delay(1000);
    }
    else if (ESP_STRING.endsWith("r3off") || ESP_STRING.endsWith("switch
three off") || ESP_STRING.endsWith("switch 3 off"))
    {
        digitalWrite(5, HIGH);
        lcd.clear();
        lcd.setCursor(0, 2);
        lcd.print("      Switch 3 OFF      ");
        delay(1000);
    }
    else if (ESP_STRING.endsWith("r4off") || ESP_STRING.endsWith("switch
four off") || ESP_STRING.endsWith("switch 4 off"))
    {
        digitalWrite(6, HIGH);
        lcd.clear();
        lcd.setCursor(0, 2);

```

```

        lcd.print("    Switch 4 OFF    ");
        delay(1000);
    }
    else if (ESP_STRING.endsWith("alloff") || ESP_STRING.endsWith("all
switch off") || ESP_STRING.endsWith("all switch of"))
    {
        digitalWrite(3, HIGH);
        digitalWrite(4, HIGH);
        digitalWrite(5, HIGH);
        digitalWrite(6, HIGH);
        lcd.clear();
        lcd.setCursor(0, 2);
        lcd.print("  All Switches OFF  ");
        delay(1000);
    }
    else
    {
    }
}
delay(3000);
}
//***** ESP_8266 Functions *****//

void findIp(int time1) //check for the availability of IP AddressSerial2
{
    int time2 = millis();
    while (time2 + time1 > millis())
    {
        while (ESP8266.available() > 0)
        {
            if (ESP8266.find("IP has been read"))
            {
                No_IP = true;
            }
        }
    }
}

void showIP()          //Display the IP Address ESP8266
{
    IP = "";
    char ch = 0;
    while (1)
    {
        ESP8266.println("AT+CIFSR");
        while (ESP8266.available() > 0)
        {
            if (ESP8266.find("STAIP, "))
            {
                delay(1000);
                Serial.print("IP AddressSerial2:");
                while (ESP8266.available() > 0)
                {
                    ch = ESP8266.read();
                    if (ch == '+')
                        break;
                    IP += ch;
                }
            }
            if (ch == '+')
                break;
        }
    }
}

```

```

    }
    if (ch == '+')
        break;
    delay(1000);
}
Serial.print(IP);
Serial.print("Port:");
Serial.println(80);
}

void establishConnection(String ESP8266and, int timeOut) //Define the
proceSerial2 for sending AT ESP8266ands to module
{
    int q = 0;
    while (1)
    {
        Serial.println(ESP8266and);
        ESP8266.println(ESP8266and);
        while (ESP8266.available())
        {
            if (ESP8266.find("OK"))
                q = 8;
        }
        delay(timeOut);
        if (q > 5)
            break;
        q++;
    }
    if (q == 8)
        Serial.println("OK");
    else
        Serial.println("Error");
}

void wifi_init() //send AT ESP8266 ands to module
{
    establishConnection("AT", 100);

    establishConnection("AT+CWMODE=3", 100);
    establishConnection("AT+CWQAP", 100);
    findIp(5000);
    if (!No_IP)
    {
        Serial.println("Connecting Wifi....");
        establishConnection("AT+CWJAP=\"iPhone\", \"01234567\"", 7000);
        //provide your WiFi username and Password here
    }
    else
    {
        }
        Serial.println("Wifi Connected");
        establishConnection("AT+CIPMUX=1", 5000);
        establishConnection("AT+CIPSERVER=1,80", 7000);
    }
}

void MeasureValues()
{
    CurrentVoltageSensor.calcVI(30, 1000); //
    Calculate all. No.of half wavelengths (crossings), time-out
}

```

```

    Real_Power, Power_Factor, Voltages, Current, Reactive_Power = 0; // All
Parameters Values Become Zero

    Power_Factor = CurrentVoltageSensor.powerFactor; //
Read Power Factor and store in Power_Factor Variable
    Voltages = CurrentVoltageSensor.Vrms; //
Read Voltages and store in Voltages Variable
    Current = CurrentVoltageSensor.Irms; //
Read Current and store in Current Variable
    delay(10);
    Reactive_Power = Voltages * Current * (1 -
Power_Factor); //extract Reactive Power into Variable
    Real_Power = Voltages * Current *
Power_Factor; //extract Real Power into Variable
    EEPROM.get(0, Units);
    Units = (Units + (Real_Power * (0.001 / 60 / 60 /
1000))); //Calculate kilowatt hours used in Units
    EEPROM.put( 0, Units);

    if (x == 0)
    {
        v1 = Voltages;
        p1 = Real_Power;
    }

    if (x == 10)
    {
        v2 = Voltages;
        p2 = Real_Power;
        x = 0;
    }
    Sensi = ((v1 - v2) / (p1 - p2));
}

void PrintValues()
{
    lcd.clear();
    lcd.setCursor(0, 0);
    lcd.print("-SMART-ENERGY-METER-");

    lcd.setCursor(0, 1);
    lcd.print("V=");
    lcd.print(Voltages);
    lcd.setCursor(11, 1);
    lcd.print("I=");
    lcd.print(Current);

    lcd.setCursor(0, 2);
    lcd.print("P.F=");
    lcd.print(Power_Factor);
    lcd.setCursor(11, 2);
    lcd.print("W=");
    lcd.print(Real_Power);

    lcd.setCursor(0, 3);
    lcd.print("Sen=");
    lcd.print(Sensi, 2);
    lcd.setCursor(9, 3);
    lcd.print("Unit=");
    lcd.print(Units, 3);
}

```

```
// Serial.print("Sen=");  
// Serial.println(Sensi, 2);  
// Serial.print("Real_Power = ");  
// Serial.println(Real_Power);  
// Serial.print("Reactive_Power = ");  
// Serial.println(Reactive_Power);  
// Serial.print("Power_Factor = ");  
// Serial.println(Power_Factor);  
// Serial.print("Voltages = ");  
// Serial.println(Voltages);  
// Serial.print("Current = ");  
// Serial.println(Current);  
// Serial.print("Unit=");  
// Serial.println(Units, 6);  
}
```

## Appendix E: Operation Manual

**First Step:** Plug-in the power cord of energy meter 220VAC 50Hz.

Wait 1 Min for Wi-Fi Connection.



**Second Step:** Now you can see the IP Address on LCD in this format (192.168.1.3).

After 10 Seconds Main screen is appears, wait 30 Seconds for Current & Voltages Calibration.

**Third step:** Enter that IP address on mobile app for operating switches.

**Fourth step:** Now you can see the main screen, in this screen you can see the Voltages, Current, Power, Energy Consumption and Sensitivity of the System.



**Fifth Step:** Now you can connect the load on sockets.



Switch 1 is ON by default and other three switches is OFF by default, you can control all the switches via Mobile App.

**Sixth Step:** You can control Switches via Mobile App and monitor all the parameters on LCD Screen.