



Prince Mohammad Bin Fahd University
Department of Electrical Engineering

Optimal Sinusoidal-with-Ripple Battery Charging System

April 21, 2021

Advisor: Dr. Ala Raef Al-Haj Hussein

Presenting by:	ID
Abdulmajeed Al-Abdusalam	201601192
Hasan Ali Alseni	201401985
Meenhal Al-najjar	201602727
Hani Quraish	201500147

OUTLINE

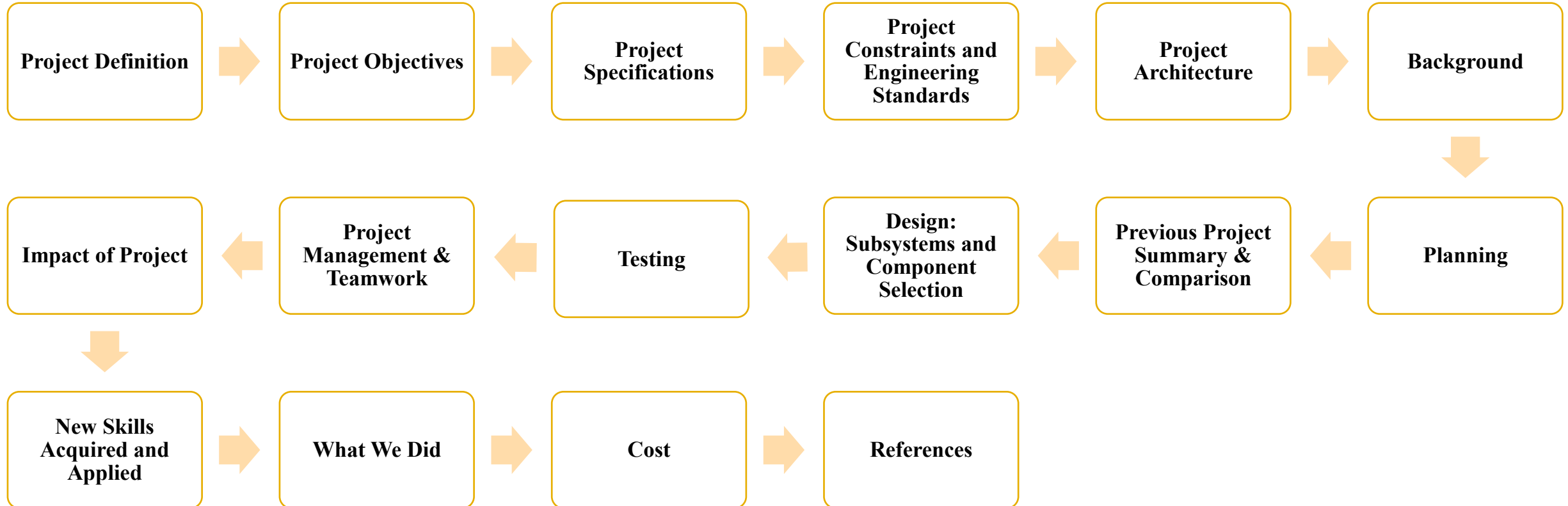

Project Definition

The project can be defined as an approach to optimize sinusoidal ripple-current charging used to increase both charging efficiency and energy efficiency and decrease charging time when used to charge lead-acid battery cells. The hardware and software of the system will be designed to track the optimal charging frequency.

Project Objectives

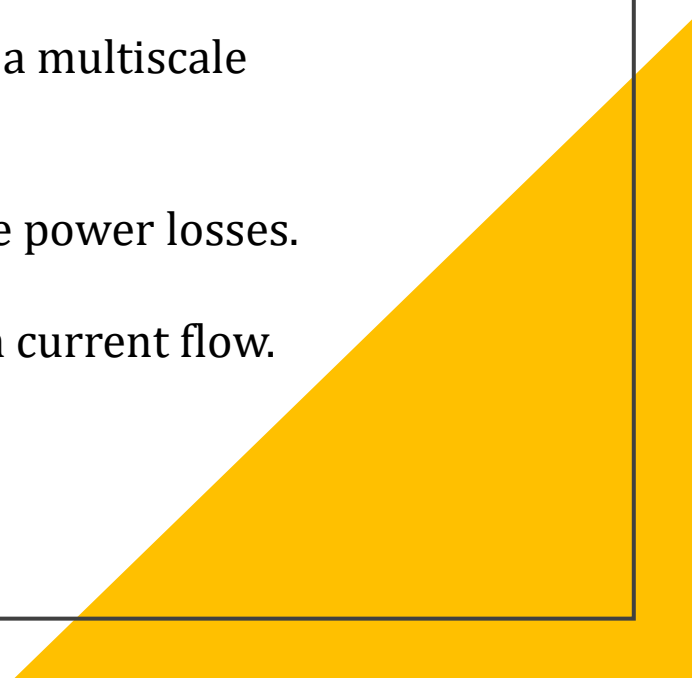
1. Optimize the charging rate of the battery in a way that works best with battery chemistry.
 2. Accelerate the charging process.
 3. Provide fast charging by avoiding a multiscale problem such as:
 - A. The high currents which cause power losses.
 - B. Overheat associated with high current flow.
- 
- A yellow triangular graphic is located in the bottom right corner of the slide, pointing towards the top right.

The project consists of two stages which are designing and testing:

1. Test variable charging frequency results using sinusoidal charging tests.
2. Optimal frequency is within the range of 10 Hz - 1 kHz for lead-acid battery cells.
3. Minimize impedance by allocating the optimal charging frequency.
4. Perform an efficiency test by measuring temperature and time charging.

Project Specifications

Project Constraints and Engineering Standards

- **Design Constraints: Sustainability**

- **Highly Recyclable**

- Lead-acid batteries are essentially 100% recyclable

- **Energy Efficient**

- Lead acid batteries efficiencies closer to 80 and 85 percent

- **Design Constraints: Safety**

- **Safe Storage**

- Used lead acid batteries are a controlled hazardous waste, must be stored, handled, transported, and recycled in accordance with environmental factors



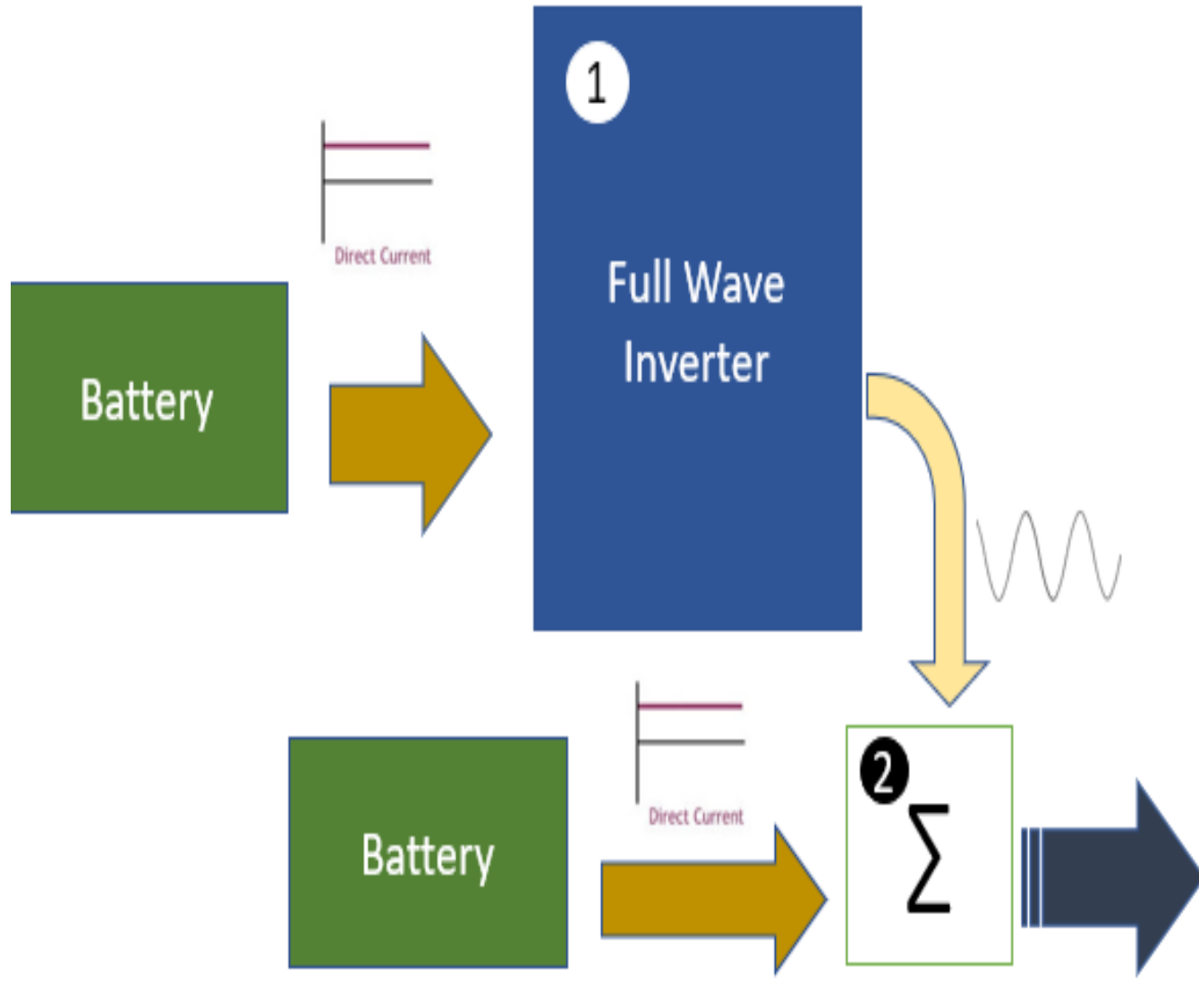

Project Architecture

Title: Optimal Sinusoidal-with-Ripple Battery Charging System		Advisor: Dr. Ala Raef Al-Haj Hussein		Design II (ASSE 3)		Spring 2021																
Hani Quraish (H.Q) 201500147		Project PLAN & Progress																				
Hasan Ali Alseni (H.S) 201401985		ProgRpt No. 6																				
Abdulmajeed Al-Abdusalam (A.A) 201601192		Plan updated (Date): April 20, 2021																				
Meenhal Al-najjar (M.N) 201602727		Instructor: Dr. Sadiq Ali Alhuwaidi																				
		Period Highlight		4		Plan Actual																
		actual (beyond plan)		Complete (beyond plan)																		
ACTIVITY	PLAN	PLAN	ACTUAL	ACTUAL	PERCENT	Periods (Weeks 1-15)																
	START	RATIO	To	START	URATIO	COMPLETE	1	2	3	4	5	6	7	8	9	10	11	12	13	14	15	
Writing Plan	1	1	H.S,M,N	1	1	100%	█															
Prepare Requirments	1	1	H.S,M,N	1	1	100%	█															
Buy Components	2	1	A.A,H.S	2	1	100%		█														
Design Subsystem 1&2 (H-bridge& Variable Frequency)	3	1	.S,A,A,M.	3	1	100%			█													
Implement Subsystem 1 (H-bridge)	3	1	.S,A,A,M.	3	1	100%			█													
Testing Subsystem 1 (H-bridge)	4	2	.S,A,A,M.	3	1	100%				█												
Implement Subsystem 2 (Variable Frequency)	4	2	H.S,A,A	4	1	100%					█											
Testing Subsystem 2 (Variable Frequency) (Inverter)	5	2	ALL	4	3	100%						█										
Design Subsystem 3 Charging Station (Coupling Inverter's Output with DC)	6	1	H.S	5	1	100%							█									
Implement Subsystem 3	6	2	A.A,M,N	6	1	100%								█								
Testing Subsystem 3	7	2	.S,A,A,H.	7	2	100%									█							
Prepare Mid-term Presentation and Video	8	1	ALL	7	2	100%										█						
Combine Subsystems	9	2	H.S,M,N	9	1	100%											█					
Measure Voltage Across Tested Battery	10	3	H.S,M,N	13	2	100%												█				
Design & Implement Industrial Design (Prototype)	11	2	H.S	8	1	100%													█			
Prepare Final Report	12	3	.I,Q,A,A,H.	10	2	100%														█		
Prepare Final Presentation	12	3	ALL	12	1	100%															█	
Prepare Project Demo	14	2	ALL	12	1	100%																█
Submit Rpt/PPT/Brochure/Video...etc	15	1	H.S	14	1	100%																█

Planning

Background: Problem

- The demand for portable products is showing exponential growth.
- Growth in volume has increased demand for greater features and functions.

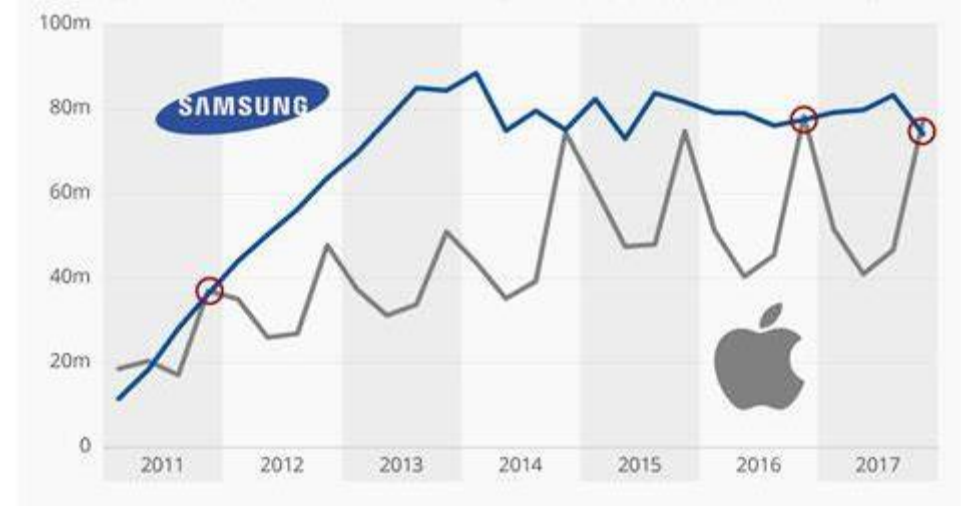

Battery life

Sony Xperia Z3	9h 29 min (Excellent)
Samsung Galaxy Note 4	8h 43 min (Excellent)
Google Nexus 6	7h 53 min (Good)
Samsung Galaxy S6	7h 14 min (Good)
Samsung Galaxy Note Edge	7h 8 min (Good)
Apple iPhone 6 Plus	6h 32 min (Average)
HTC One M9	6h 25 min (Average)
LG G3	6h 14 min (Average)
LG G4	6h 6 min (Average)
Apple iPhone 6	5h 22 min (Poor)



Background: Solutions

- A new method is used for allocating and tracking the optimal charging frequency for sinusoidal chargers.
 - The method has a superior performance in terms of convergence speed, ease of implementation, and applicability to different battery types.
-

**Previous
Project**

**Summary
&
Comparison**



All of the projects agree on:



Minimizing charging time



**Maximizing the charging efficiency
and lifetime of the battery**



**Minimizing temperature rise of
batteries during charging**

Testing by MATLAB-Simulink

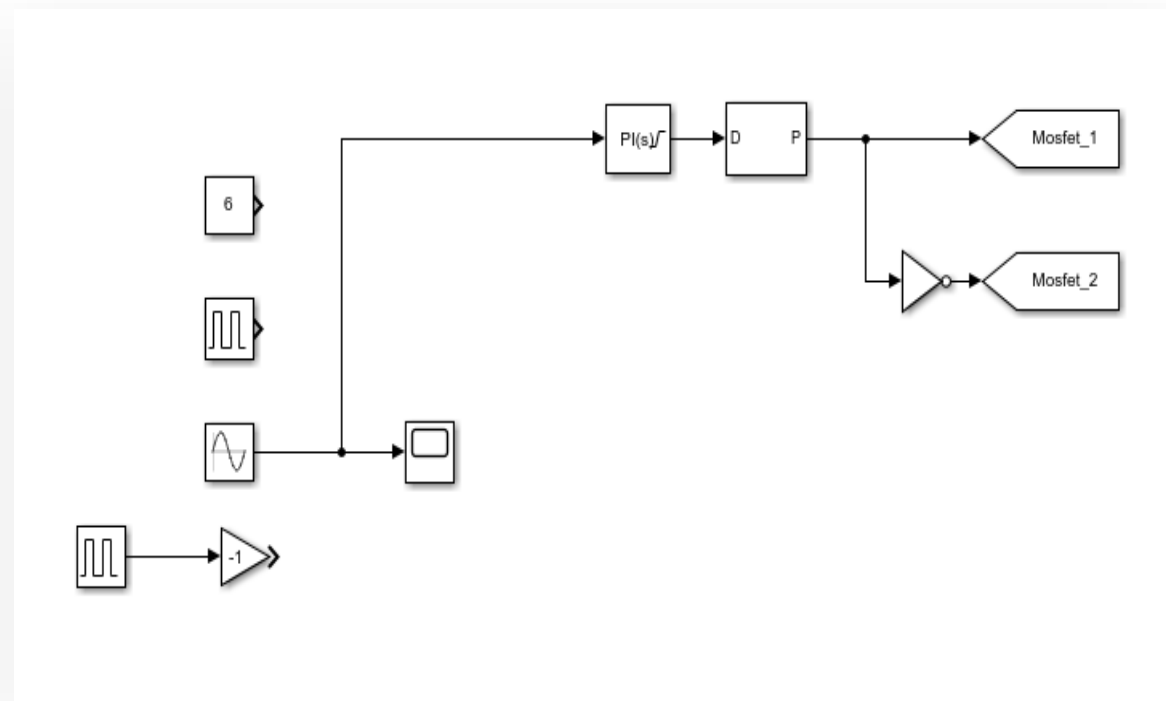
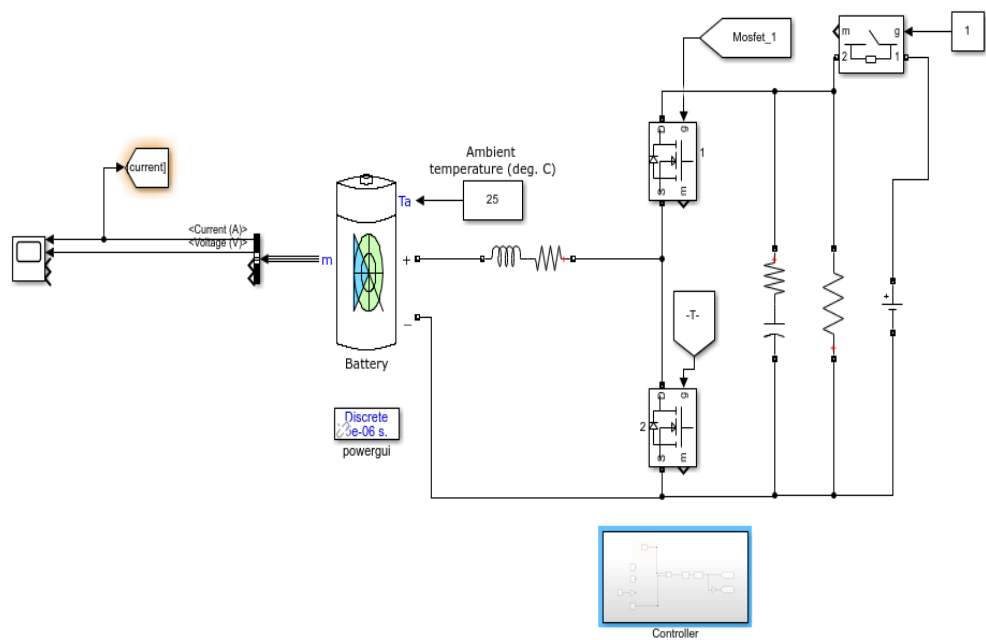

Battery Charging Platform

Charging Battery Simulation's Result

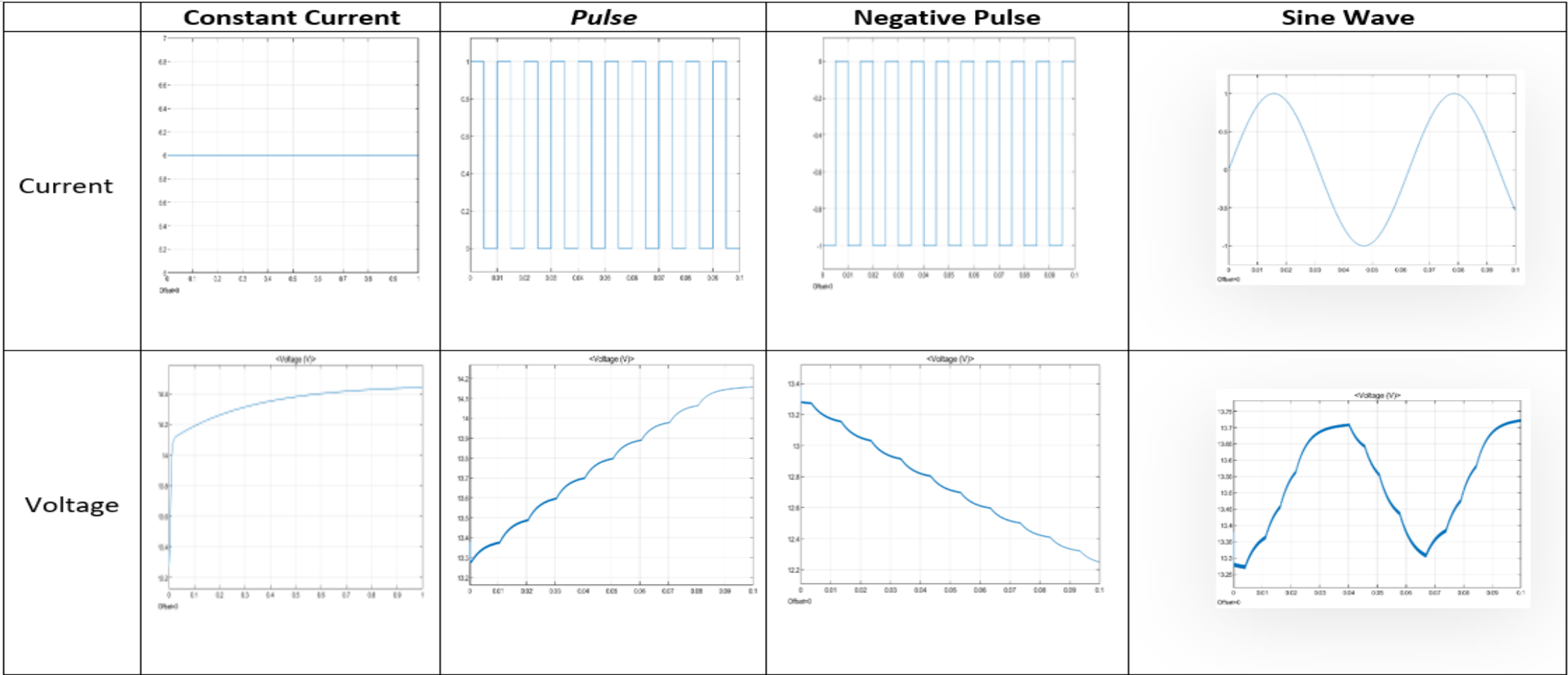

Full Design System

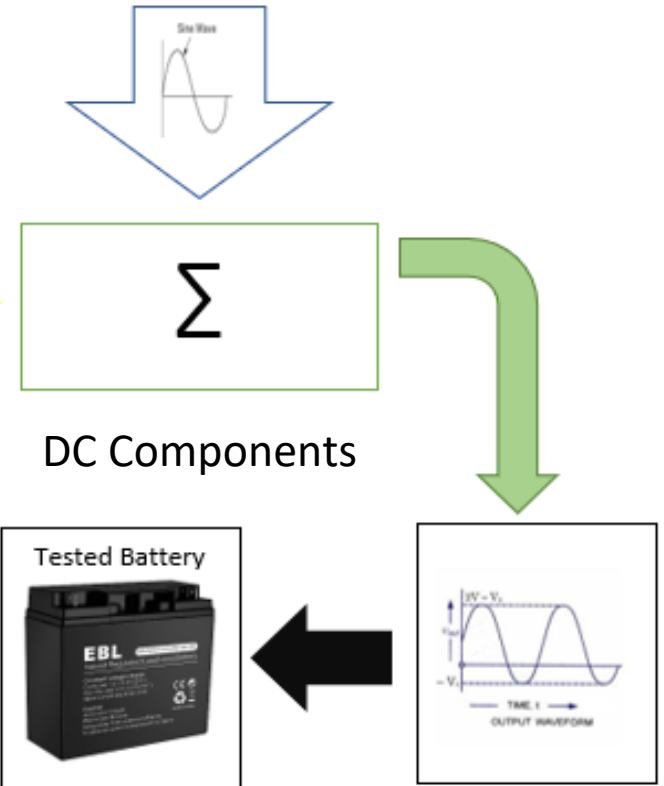
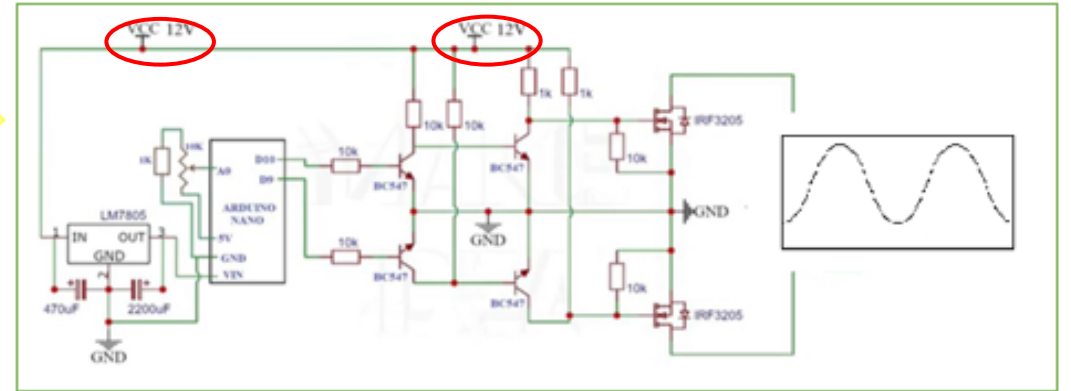
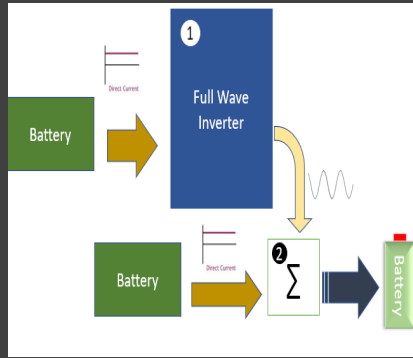

Full Wave Inverter

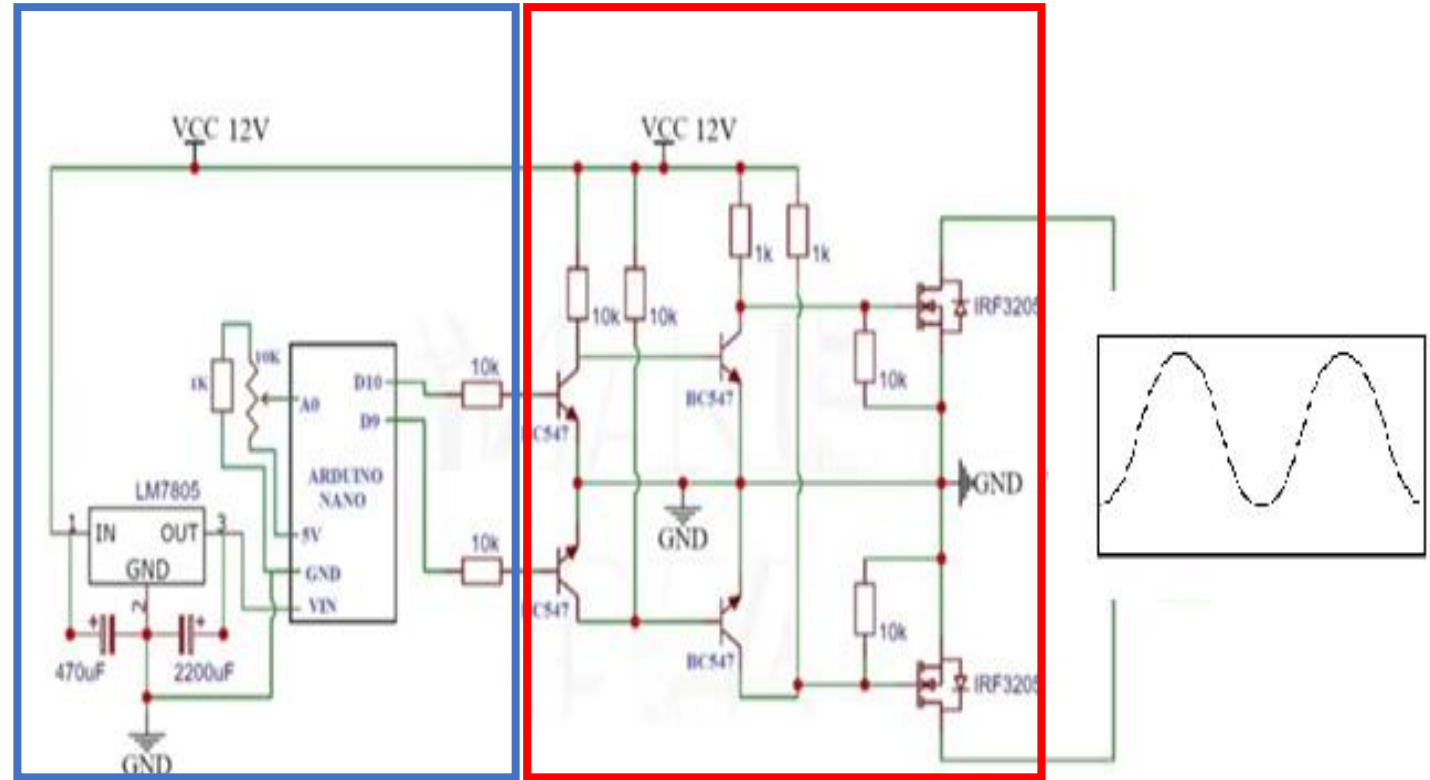
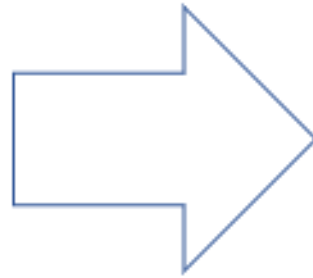

Subsystem 2 (Variable Frequency) Subsystem 1 (H-bridge)

Design

Subsystems and Components Selection

Subsystem 1&2 Implementation

Objective of Subsystem 1 and 2:

Subsystem 1:

H-Bridge to produce sine wave signal

Subsystem 2:

Arduino Nano to make a variable frequency

Subsystem 1
(H-bridge)

Subsystem 2

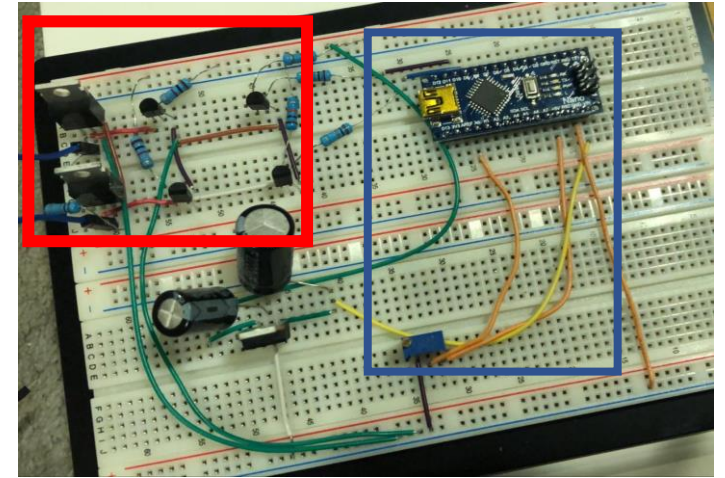

Components of:

Subsystem 1:

4 NPN Transistors
2 MOSFETS'

Subsystem 2:

Arduino Nano

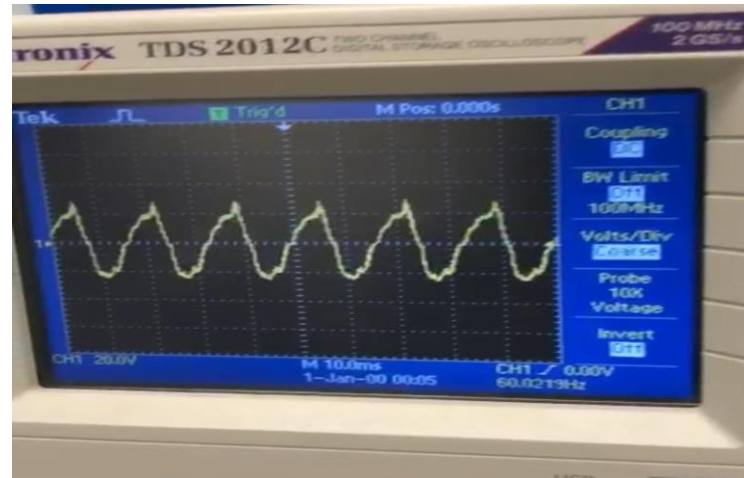

Subsystem 1 (H-bridge) Result

Full Wave Inverter subsystems Implementation

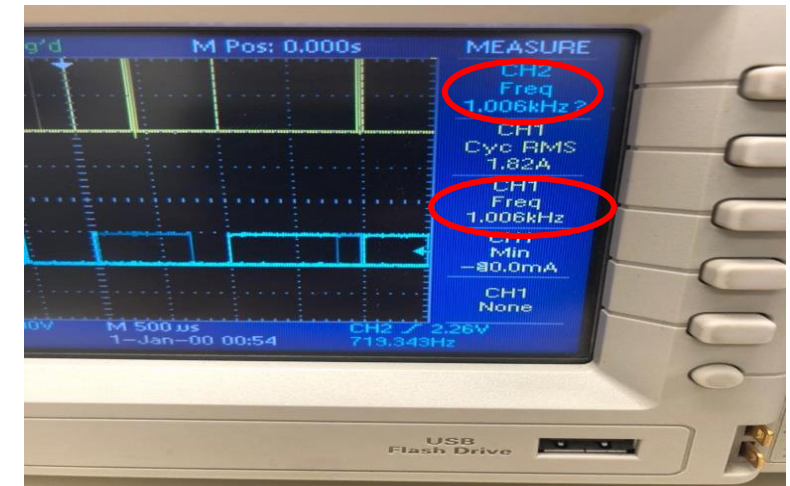

Subsystem 2's result taken from PIN D9, and D10

Subsystem 1&2 Alternative Circuit

❑ Objective of Alternative Circuit:

- To generate sine wave signal
- To make a variable frequency from 10 Hz to 1 kHz

❑ Components

- Arduino UNO
- AD9833 function generator module
 - To provide various signals

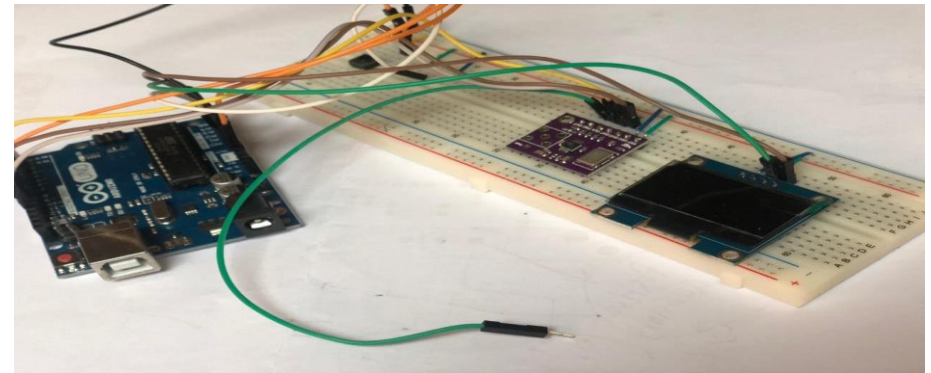

Full Wave Inverter Implementation

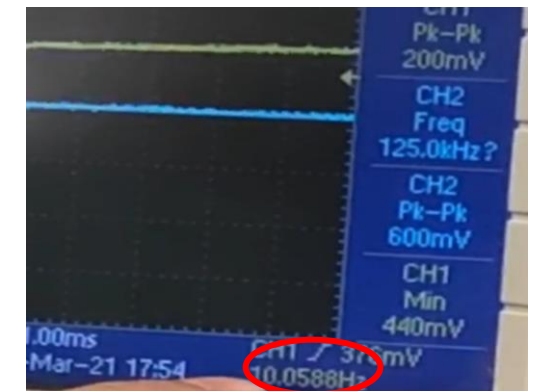
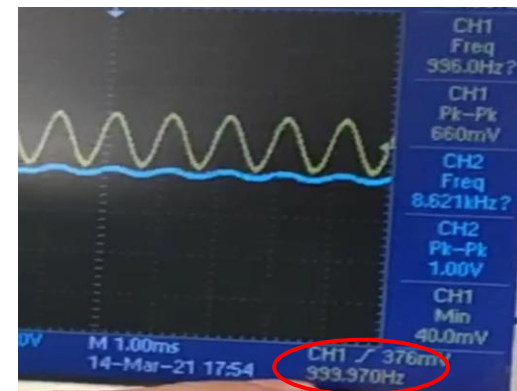

Alternative Circuit's Result: Maximum & Minimum Frequency

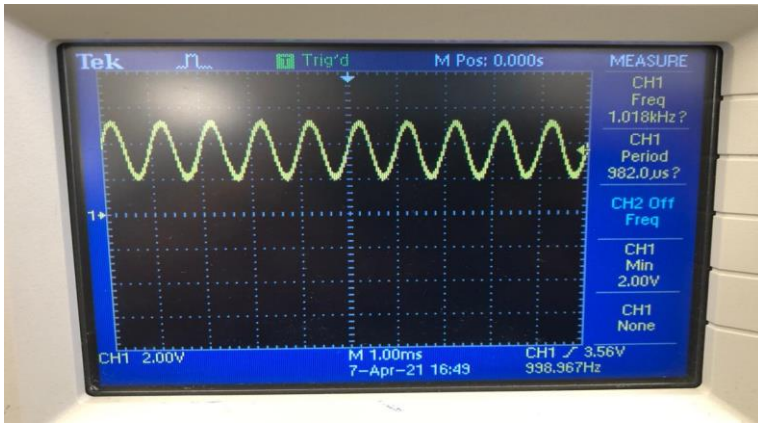

Output of Sine Wave with 1 kHz

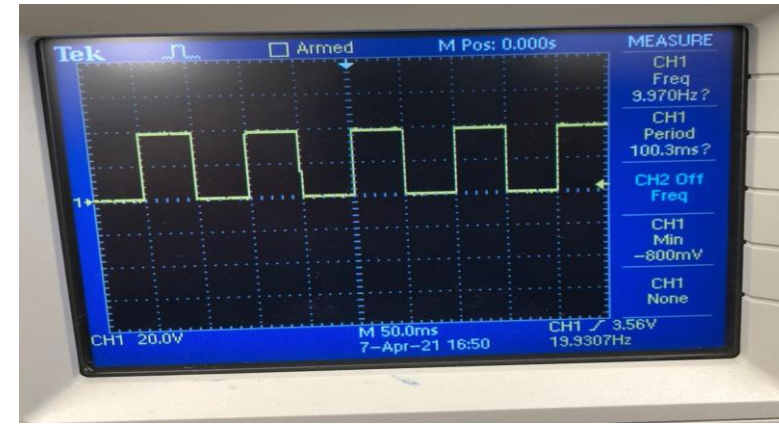

Output of Square Wave

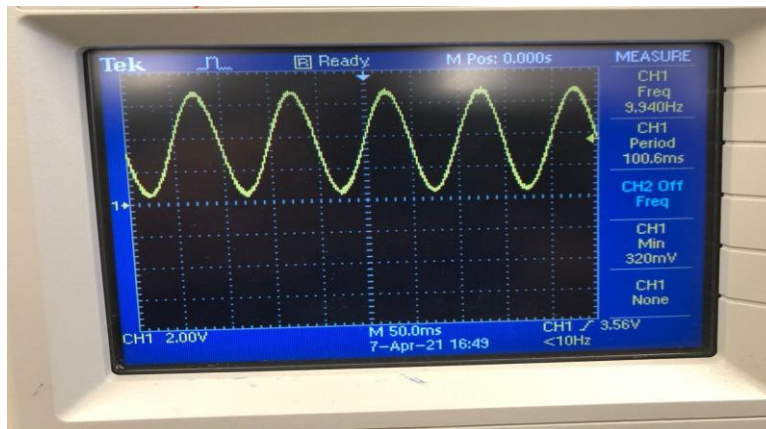

Output of Sine Wave with 10 Hz

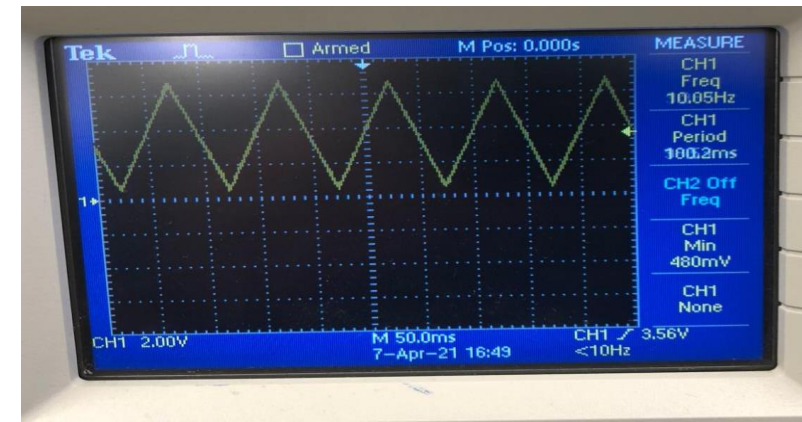

Output of Triangle Wave

Alternative Circuit's Result

Subsystem 3 (Combining Subsystems Simulation)

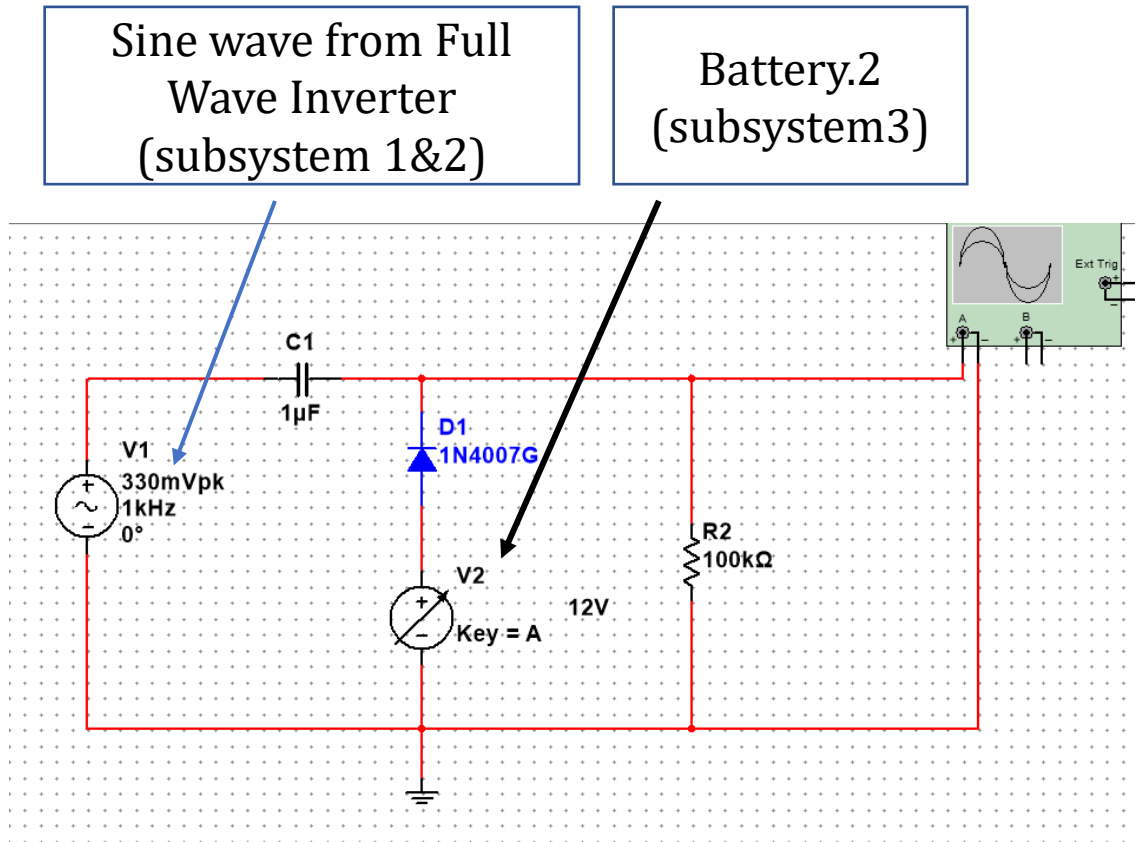

DC Components (DC Offset) Simulation by Multisim

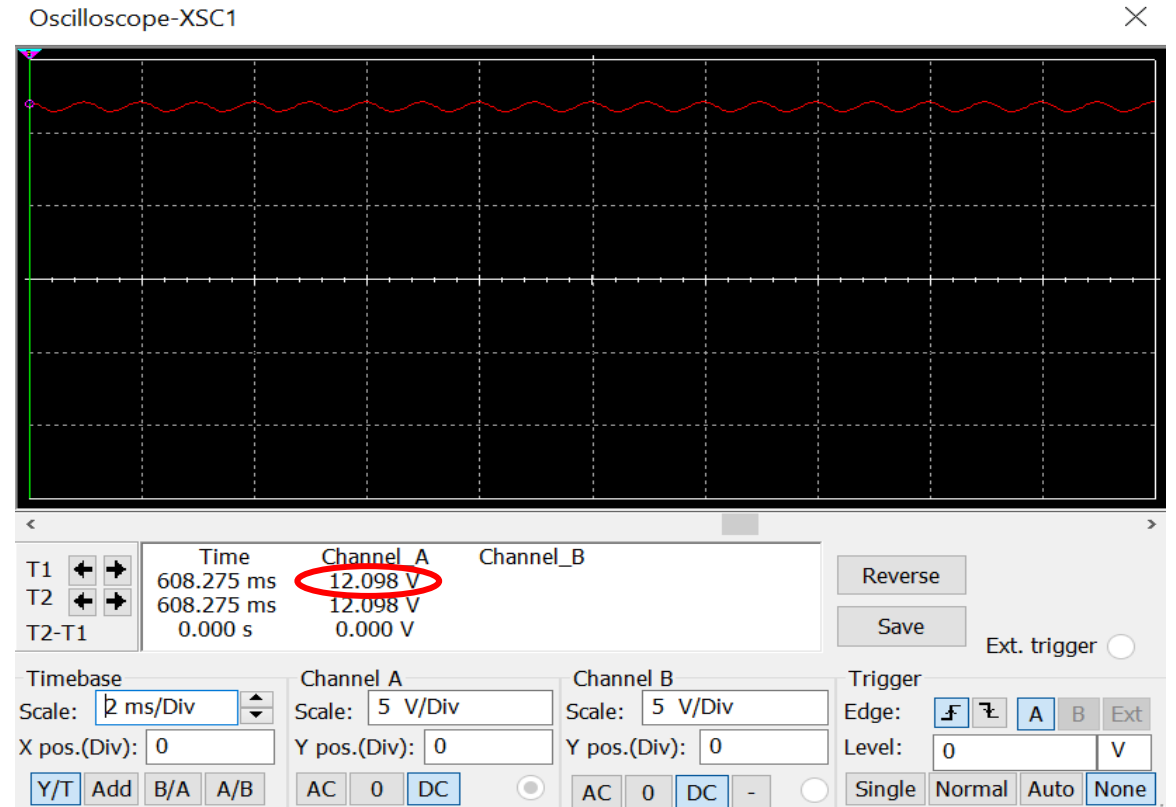

Simulation's Result (Sinusoidal Current with Ripple)

Subsystem 3 Implementation

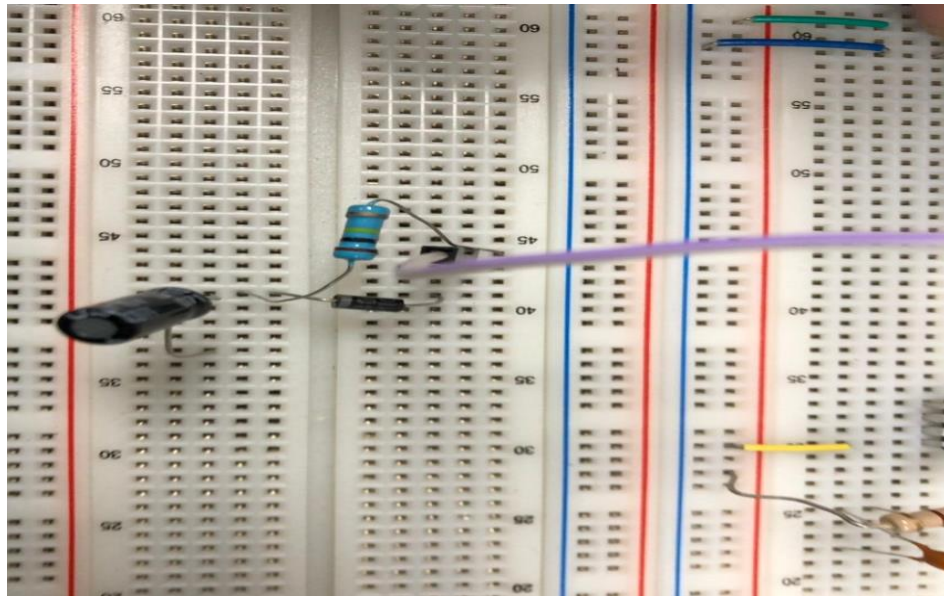

Subsystem 3 Implementation

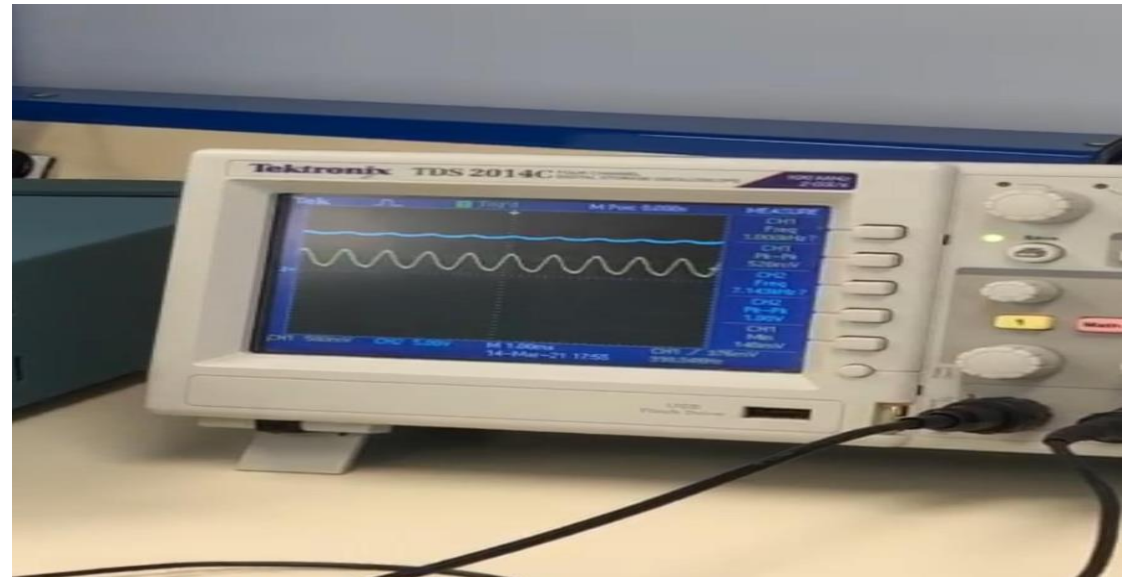

Channel 1: Alternative Circuit's Result

Channel 2: Subsystem 3's Result



Testing of The System

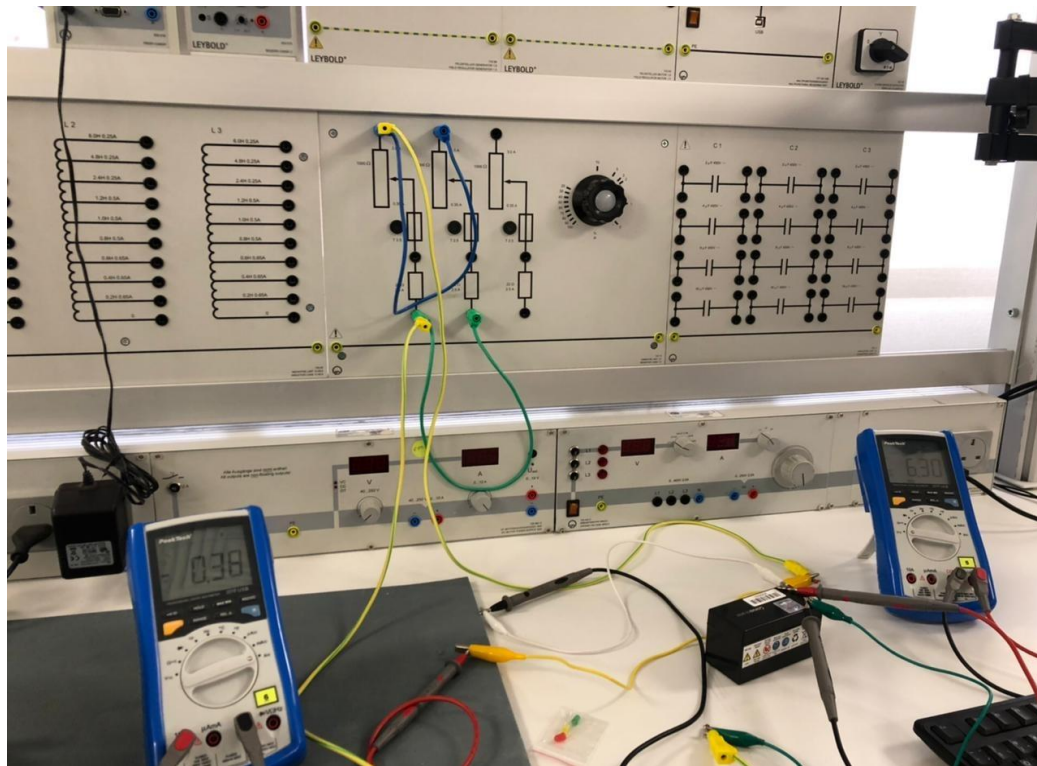

Discharging a Battery Using Lab's Load

t (min)	V(v)	T(C°)
0	8	25.6
2	8.27	24.3
4	8.35	24
6	8.12	24
8	8.46	23.8
10	8.49	23.7
12	8.51	23.6
14	8.54	23.9
16	8.55	24
18	8.57	23.9
20	8.58	23.9
22	8.60	23.9

DC Charging Technique

t (min)	V (v)	I (mA)	T (C°)
0	8	180	25.8
2	9.9	130	25.3
4	10.07	90	25
6	10.24	30	24.8
8	10.31	40	24.5
10	10.35	30	24.5
12	10.38	20	24.1
14	10.48	20	23.8
16	10.39	10	23.7
18	10.39	10	23.3
20	10.39	10	23.1
22	10.39	10	23
24	10.39	10	23.5
26	10.39	10	23.6

Sinusoidal with Ripple Charging Technique Using 30 Hz

Project Management & Teamwork

Task	Abdulmajeed	Hasan	Hani	Menhal
Simulation Using Simulink	20%	15%	35%	30%
Implement Subsystems	35%	30%	20%	15%
Test Subsystems	30%	35%	15%	20%
Measure Efficiency of Tested Battery	15%	20%	30%	35%

Project Management & Teamwork

#	RISK ASSESSMENT	IMPACT	HOW WE MANAGE
1	Delay of receiving components	Delay of submitting the project	Extend our researches and find alternative circuit with components that are available in the market
2	Some components were not as in the specifications	Reorder the components which cause implementation delay.	Find alternative supplier that can provide it in shorter period
3	Team members live in different cities	Minimize gathering which will lead to slow the implementation progress	Utilize technology and meet online using different platforms such, Zoom, PMU Blackboard, and other social media software

Impact of Project



LESS CHARGING TIME



TEMPERATURE-SENSITIVE DESIGN

New Skills Acquired and Applied

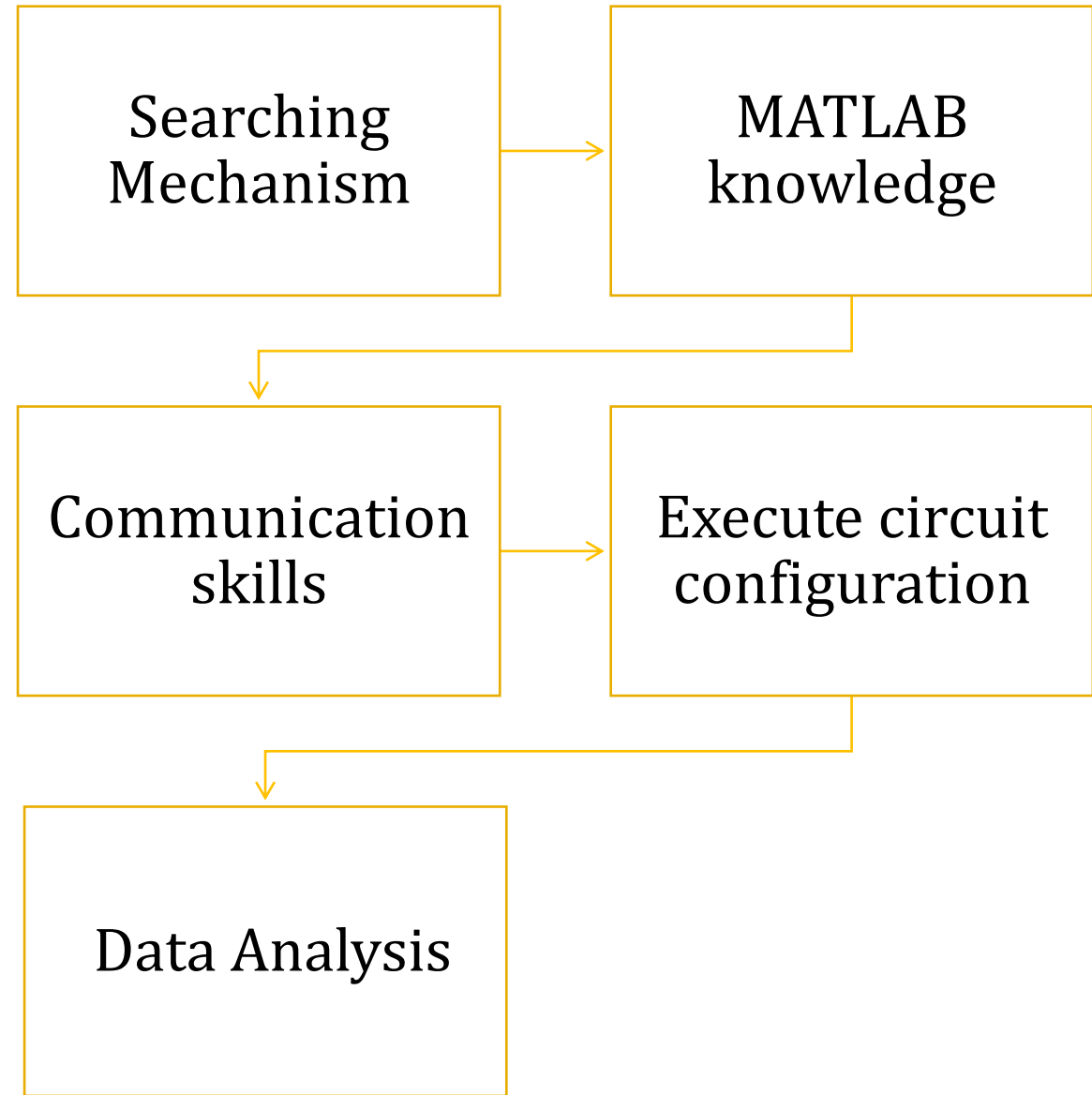

What We Did

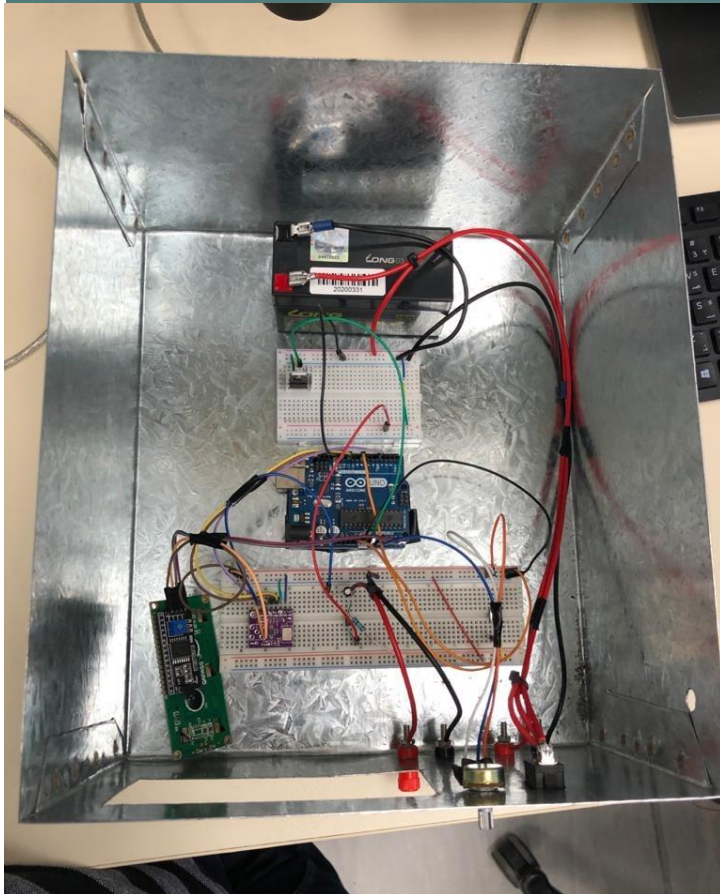

- Reading Research Papers
- Simulation Using Simulink
- Buying Components
- Implementing Subsystems
- Testing Subsystems
- Combining Subsystems Together
- Measure Efficiency of Tested Battery
- Complete The Implementation of The Industrial Design (Prototype)

Cost

No.	Description	Quantity	Unit Cost (SR)	Total Cost (SR)
1	Acid Batteries	2	100	200
2	Microcontroller-Arduino	1	90	90
3	AD9833 Function Generator Module	1	60	60
4	16x2 LCD Display with I2C	2	50	50
5	Miscellaneous Items Capacitors, Resistors, and Wires...etc	-	-	150
Totals				550 SAR

Project Video





**Thank You
for Your Attention**

References

1. Hussein, A. A., Fardoun, A. A., & Stephen, S. S. (2017). An ultrafast maximum power point tracking technique for optimal battery charging. *IEEE Transactions on Sustainable Energy*, 8(3), 1321-1329.
2. Cope, R. C., & Podrazhansky, Y. (1999, January). The art of battery charging. In *Fourteenth Annual Battery Conference on Applications and Advances. Proceedings of the Conference (Cat. No. 99TH8371)* (pp. 233-235). IEEE.
3. Chen, L. R., Wu, S. L., Shieh, D. T., & Chen, T. R. (2012). Sinusoidal-ripple-current charging strategy and optimal charging frequency study for Li-ion batteries. *IEEE Transactions on Industrial Electronics*, 60(1), 88-97.
4. Hussein, A. A. H., & Batarseh, I. (2011). A review of charging algorithms for nickel and lithium battery chargers. *IEEE Transactions on Vehicular Technology*, 60(3), 830-838.