



جامعة الأمير محمد بن فهد
PRINCE MOHAMMAD BIN FAHD UNIVERSITY

College of Engineering

Department of Electrical Engineering

Spring 2018-19

Senior Design Project Report

Footstep Piezo Generator

**In partial fulfillment of the requirements for the
Degree of Bachelor of Science in Electrical Engineering**

Team Members

	Student Name	Student ID
1	Khalid Al-Hamoudi	201401006
2	Jubarah Almudhaki	201401010
3	Ahmed Khalid	201402729
4	Azeb Alqahtani	201400530

Project Advisors:

Advisor Name: Samir El-Nakla
Co-Advisor Name: Chedly Yahya

Abstract

Here we propose an advanced footstep power generator system that uses piezo sensors to generate power from human footsteps. The system allows for a platform for placing footsteps. The piezo sensors are mounted below the platform to generate voltage from footsteps. The sensors are placed in such an arrangement so as to generate maximum output voltage. This is then provided to our monitoring circuitry. The circuit is a microcontroller based monitoring circuit that counts the number of steps applied on the weighting plate and the voltage across the capacitor in the rectifier circuit. Then it displays all this information on an LCD screen.

Table of Contents

<i>Abstract</i>	2
1. Introduction	5
1.1 Project Definition.....	5
1.2 Project Objectives	5
1.3 Project Specifications.....	5
1.4 Product Architecture and Components.....	5
1.5 Applications	6
2. Literature Review	6
2.1 Project background.....	6
2.2 Previous Work.....	7
2.3 Comparative Study.....	9
3. System Design	9
3.1 Design Constraints	9
3.1.1 Design Constraints: Engineering Standards.....	Error! Bookmark not defined.
3.1.2 Design Constraints: constraint name.....	Error! Bookmark not defined.
3.1.3 Design Constraints: constraint name.....	Error! Bookmark not defined.
3.2 Design Methodology	10
3.3 Product Subsystems and Components.....	Error! Bookmark not defined.
3.3.1 Product Subsystem1: name Comm, Control	11
3.3.2 Product Subsystem2: name Comm, Control	11
3.3.3 Product Subsystem3: name Comm, Control	Error! Bookmark not defined.
3.4 Implementation	11
4. System Testing and Analysis.....	12
4.1 Subsystem 1: Weighting machine	12
4.2 Subsystem 2: Monitoring circuit	12
4.3 Overall Results, Analysis and Discussion	13
5. Project Management	15
5.1 Project Plan	15
5.2 Contribution of Team Members	16
5.3 Project Execution Monitoring	16
5.4 Challenges and Decision Making.....	17
5.5 Project Bill of Materials and Budget.....	17
6. Project Analysis.....	18
6.1 Life-long Learning	18
6.2 Impact of Engineering Solutions	19
6.3 Contemporary Issues Addressed	19
7. Conclusions and Future Recommendations.....	Error! Bookmark not defined.
7.1 Conclusions.....	20
7.2 Future Recommendations.....	20

8. References	22
Appendix A: Progress Reports	23
Appendix B: Bill of Materials	24
Appendix C: Datasheets	25
Appendix D: Program Codes.....	25
Appendix E: Operation Manual.....	26

1. Introduction

1.1 Project Definition

To design a system that generates voltage by the humane footsteps force. Using non-conventional sources and stores it for usage. The system will have piezoelectric sensors that will convert the measurements of acceleration, force and pressure into electrical signals. It will fully depend on the human footsteps pressure and convert it into useful power.

1.2 Project Objectives

- Generating power out of free energy.
- To spend less money on power generating.
- To encourage people to use different economical ways of generating power.

1.3 Project Specifications

- 1- up to 20V DC output
- 2- Display number of steps applied and voltage generated on LCD.
- 3- 22x26 fiberglass plate.

1.4 Product Architecture and Components

Starting in our project we have two subsystems, the weighting machine and the monitoring circuit. At first by placing the piezoelectric sensors under the weighting machine as can be seen in figure 1. So that we can convert the pressure that is applied on the weighting machine into voltage (mechanical to electrical) that will be provided to the microcontroller. The monitoring

circuit is based on a microcontroller that allows us to calculate the voltage charge and display it on the LCD display.



Figure 1. (Weighting plate with piezo sensors)

1.5 Applications

- 1- In gymnasiums where people can exercise and create some power.
- 2- In dancing clubs where people can dance and generate power.
- 3- In train stations because there's usually high density of people so it can be effective.

2. Literature Review

2.1 Project background

Day by day, the population of the country increases and the requirement of the power is also increases. At the same time, the wastage of energy also

increases in many ways. So reforming this energy back to usable form is a major concern. As technology is developed and the use of gadgets, electronic devices also increased. Power generation using conservative methods becoming deficient. There is a need arises for a different power generation method. At the same time, the energy is wasted due to human locomotion. To overcome this problem, the energy wastage is converted to usable form using the piezoelectric sensor. This sensor converts the pressure on it to a voltage. By using this energy saving method, foot step power generation system we are generating power. A piezoelectric sensor is a device that uses the piezoelectric effect, to measure changes in pressure, acceleration, temperature, strain, or force by converting them to an electrical charge.

2.2 Previous Work

Previous work 1:

Foot step power generator (International Journal of Scientific & Engineering Research, Volume 8, Issue 3, March-2017, Footstep Voltage Generator using Piezo-Electric Transducers) [5].

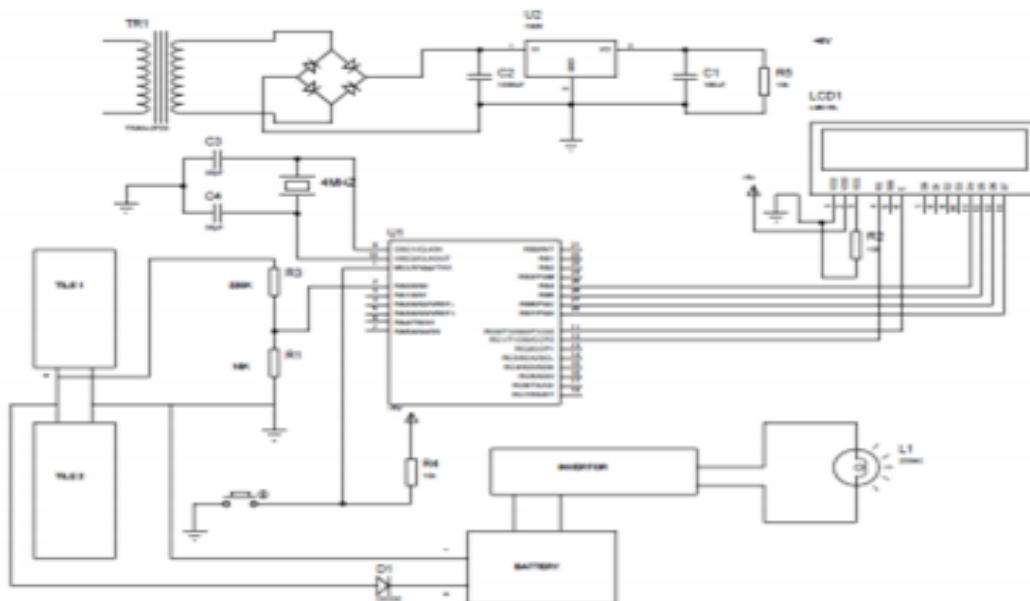

Figure 2. (Block diagram of first previous project)

- they are not using a micro controller at all but we need the microcontroller in our project because we need to transform the voltage output from analog to digital so we can read the number of steps and the max energy calculated per step
- Connection of the piezo sensor is in series but we need the connections to be in parallel so that the piezo sensor can generate more current.

Previous work 2:

Foot step power generator (Prince Mohamed Bin Fahad, 2015) [7].

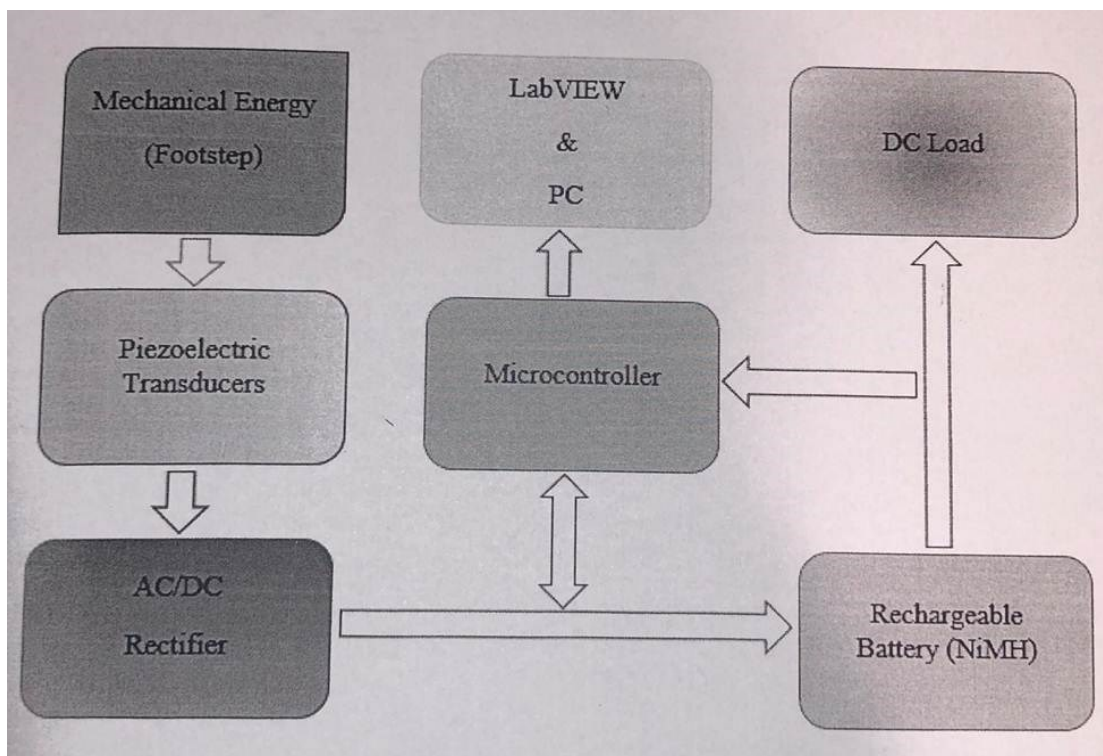

Figure 3. (Block diagram for second previous project)

- Different type of Piezo Electric Sensor.
- Multiple plates connected in series. But we need the connections to be in parallel so that the piezo sensor can generate more current
- Used a wood plate and we used a fiber glass.

- Different microcontroller MyRio and we used Arduino UNO.

2.3 Comparative Study

Table 1. (University of PMU 2015)

Setup	Maximum current
4 piezo connected in series	Up to 30 uA
4 piezo connected in parallel	Up to 45uA
1 piezo unit	Up to 40 uA

Table 2. (University of PMU 2018)

Setup with different loads	Maximum current
8 piezo connected in parallel and 1 M ohms	Up to 8.5 uA
8 piezo connected in parallel and 1K ohms	Up to 100 uA
8 piezo connected in parallel and 680 ohms	Up to 115 uA

3. System Design

3.2 Design Constraints

Environmental constraints:

The piezoelectric sensors design were addressed with respect to the waste the generator produces. The intent is to minimize power consumption of this design. The power consumption level is an environmental concern because the more power the users. We will lower power parts by generating power from free source.

Ethical constraints:

The designs were considered in relation to common morals. The project is able to perform basic tasks that reinforce important EE concepts in footpaths, hospitals, factories etc...

Health and safely constraints:

Our design was considered with respect to assembly in the lab environment. There are no additional health and safety risks involved with the advanced capabilities module.

3.2 Design Methodology

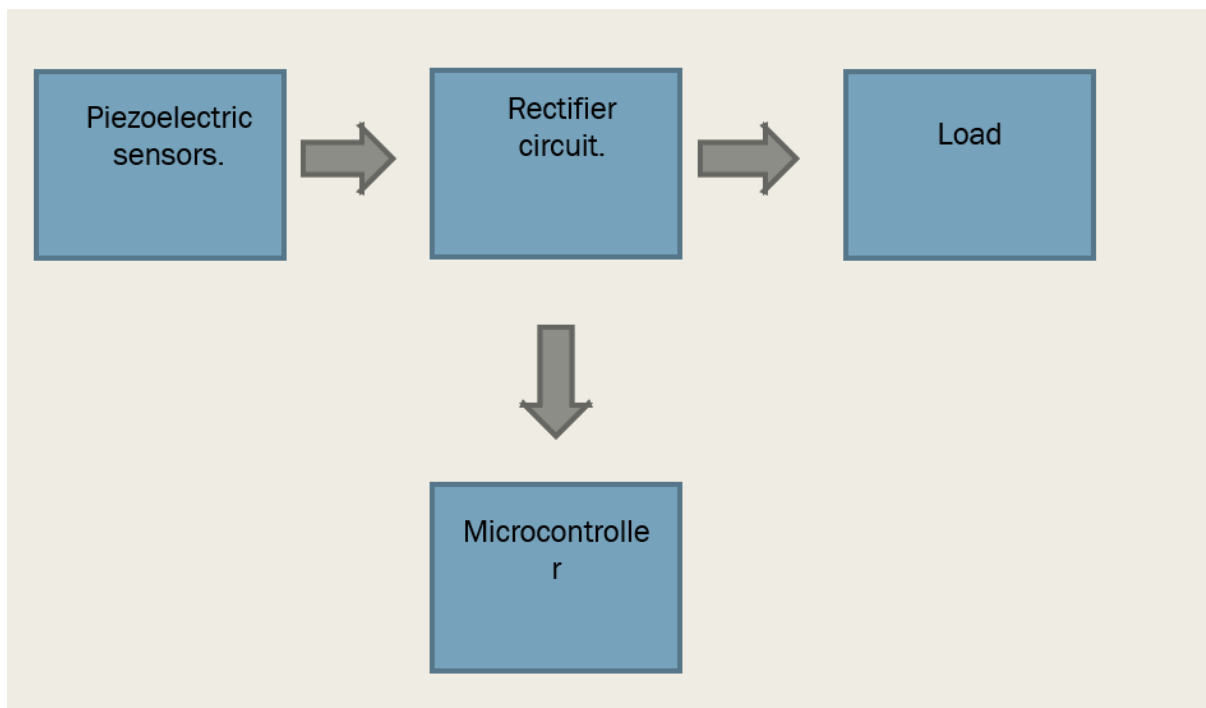

Figure 4. (Project block diagram)

The approach we took on this mission is to separate the system into two subsystems. A subsystem to work on this semester and another to work on the second semester. Starting with the weighing machine for this semester and the microcontroller for the second semester. Planning to get it done by the end of this semester to be ready to work on the second subsystem in the upcoming semester.

3.3.1 Product Subsystem1: Weighing plate and sensors

Plate: for the weighing plate we considered Plastic, Glass, Fiber glass, wood.

Sensors: We considered the large piezoelectric transducers and the small sized piezoelectric transducers, but we chose the small ones because the large ones are much more expensive and require a lot more mechanical pressure in order to generate very small power.

3.3.2 Product Subsystem2: Microcontroller.

Microcontroller: For the micro controller in our second subsystem we had a few options like Arduino or PIC, and we went with the Arduino due to being more familiar with it and due to its cheap price.

3.4 Implementation

When we integrated our system we simply connected the output of the piezo sensors to a rectifier circuit to convert the voltage to DC and then we fed that voltage into the micro controller in order to display the number of steps and voltage generated across the capacitor. We set our target specifications based on the results of experimenting and research on previous projects. We implemented our design at PMU labs with the help of the lab assistant and our advisor Dr. Samir, as well as group meetings outside the university. We verified our system performance using digital multimeters and the oscilloscope.

4. System Testing and Analysis

4.1 Subsystem 1: Weighing plate and piezo sensors.

Objectives:

- 1- Handle a certain amount of weight applied to it.
- 2- Generate power when stepping on the plate.

Setup:

For the setup for this subsystem we used a plate and placed the piezoelectric sensors below it. As for the location of testing our subsystem we used the university labs.

Table 3. (Results of the rectifier circuit)

Time	Force	Load	Voltage	Current	Power
30 seconds	735.75N (75kg)	1M ohms	10V	8.5uA	$8.5 \times 10^{-5} \text{W}$
30 seconds	735.75N (75kg)	1kohms	0.09V	100uA	$9 \times 10^{-6} \text{W}$
30 seconds	735.75N (75kg)	680ohms	0.06V	115uA	$6.9 \times 10^{-6} \text{W}$
30 seconds	735.75 (75kg)	100ohms	0.02V	140uA	$2.8 \times 10^{-6} \text{W}$

4.2 Subsystem 2: Microcontroller.

Objectives:

- 1- Display the number of steps and voltage generated.
- 2- Count the number of steps and voltage generated.

Setup:

The microcontroller takes its input from the voltage across the capacitor in the rectifier circuit in order to count the number of steps and voltage and display it on the LCD.

4.3 Overall Results, Analysis and Discussion

Based on the results we got in the first semester we started looking for solutions to increase our power generated out of the piezoelectric transducers, we performed extensive research on how to amplify our results. Then we found a circuit that amplifies both the current and the voltage generated using LM741 op-amp for the voltage and a Darlington pair using 2n3055 power transistor as shown in the figure below. But our piezoelectric transducers were generating very small power so the op-amp was taking its voltage from the external source and amplifying it and so it was not our desired goal. We also tried to use ultra-capacitors of 500F in order to collect the charge faster and release it, but we were unable to use them due to our small power generated which could not charge the capacitor. So we ended up just using the rectifier circuit and a direct load.

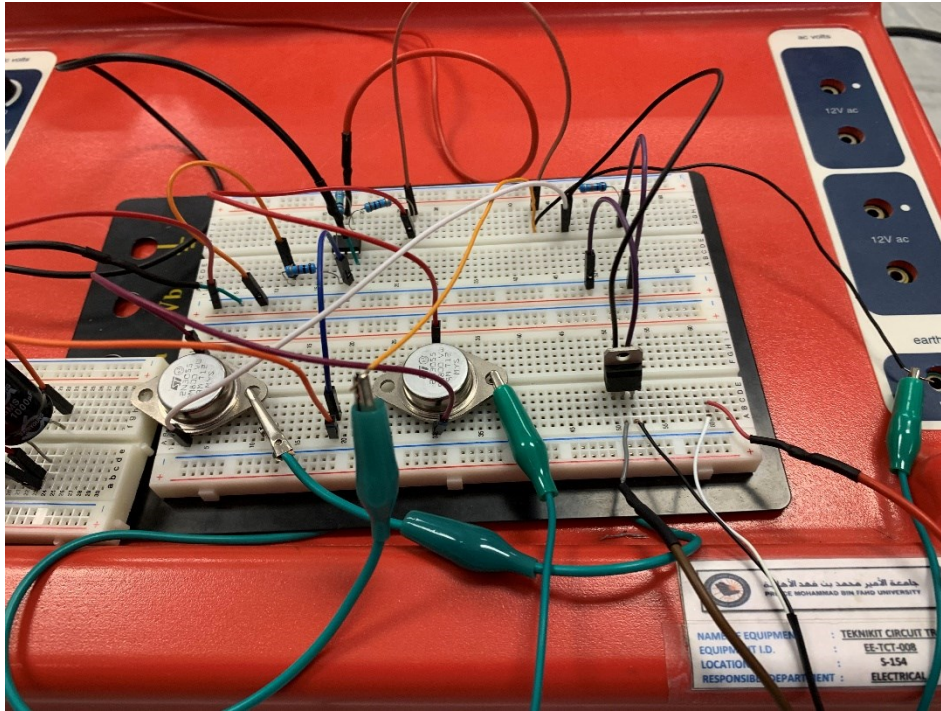

Figure 5. (Amplifying circuit)

Table 4. (Results from the amplifying circuit)

Force	Load	Voltage	Current	Power
735.75N (75kg)	2.5 ohms (phone)	5V	2mA	0.01W
735.75N (75kg)	1K ohms	5V	5mA	0.025W
735.75N (75kg)	100 Ohms	5V	17mA	0.085W
735.75 (75kg)	10 Ohms	5V	18mA	0.09W

Our goals for this project was to be able to charge a mobile phone and a 12V lead acid battery, but due to the very small power we are generating we cannot do either of them. The resources required in order to achieve our goals would be to use larger piezoelectric transducers and maybe even use multiple plates. The experiment procedure for our project is to measure the voltage and current across the capacitor in the rectifier circuit using a DMM and record our results in tables based on the loads we use. Some of the challenge we faced were such as finding a circuit that we can use to increase our power, finding affordable piezoelectric transducer to replace the ones we bought. Acquiring components took longer times than we had expected which delayed our progress,

5. Project Management

5.1 Project Plan

SN	Tasks & Responsibilities		Begin date	End date	% Completion by set end date
1	Planning; Feasibility and Reading	All	10/9/2018	17/9/2018	100%
2	Idea generation and selection	All	19/9/2018	24/9/2018	100%
3	Project Proposal	All	24/9/2018	26/9/2018	100%
4	Project management Plan	KH,JR	1/10/2018	3/10/2018	100%
5	Project first presentation	All	2/10/2018	3/10/2018	100%
6	Select & acquire components for SS1	KH,AZ	4/10/2018	11/10/2018	100%
7	Design subsystem SS1 (weighting Machine)	JR,AK	14/10/2018	21/10/2018	100%
8	Implement Design for SS1	All	22/10/2018	29/10/2018	100%
9	Test and refine design for SS1	All	2/11/2018	5/11/2018	100%

10	Design subsystem SS2 (microcontroller) (2 nd semester)	All	30/12/2018		100%
11	Implement Design for SS2 (2 nd Semester)	All	30/12/2018		100%
12	Test and refine design for SS2(2 nd Semester)	All	30/12/2018		100%
13	Integrate subsystems SS1 & SS2(2 nd semester)	All	30/12/2018		100%
14	write progress reports (weekly)	All	----	----	100%
15	Prepare Demo. (prototype)	All	22/11/2018	29/11/2018	100%
16	Prepare Final presentation	All	30/11/2018	9/12/2018	100%
17	Prepare final report	All	9/12/2018	12/12/2018	100%

1.2 Contribution of Team Members

Task	Khalid	Jubarah	Ahmed	Azeb	Task Total
Search & acquire components	25%	25%	25%	25%	100%
Design Subsystems	25%	30%	20%	25%	100%
Test Subsystems	35%	35%	15%	15%	100%
Write Reports & Presentations	50%	50%	0%	0%	100%

5.3 Project Execution Monitoring

- 1- We meet with our advisor at least once per week every Wednesday.
- 2- We meet with our team members 2 times a week.
- 3- We make sure to perform tests while all group members are present.

5.4 Challenges and Decision Making

- Problems with team members not cooperating/meeting.
- Delays in procuring required parts/components/tools.
- Problem choosing the type of sensor we needed for the project.
- Problem meeting with advisor due to having different schedule.

We solved the above problems by setting rules and giving more time to our project and by communicating with our team and advisor.

5.5 Project Bill of Materials and Budget

Name	Quantity	Price
Various capacitors	7	48
Ultra-capacitors	14	450
Various resistors	20	40
Arduino UNO	1	120
Voltage regulator	2	20
Transistor BC547	2	20
1N4007 diode	5	10
12V Battery lead acid	1	50
LCD screen	1	30
Piezoelectric material	8	150
Weighing machine	1	100
Power transistors	4	20
Other materials		150
Total		1208 SAR

2. Project Analysis

In this section, you will analyze your project in terms of the following:

6.1 Life-long Learning

During this long journey, we have gained a lot of knowledge to add to our knowledge that we have gained during the past five years. Starting with the main component of our project which is the piezoelectric sensors. It is a new component we have worked with after knowing about it in the sensor course we have taken earlier. It is interesting but not easy to work with since it requires so many experiments to understand its behavior. As well as the ultra-capacitors of

500F each. They are huge in size and amount of power that can be stored in them and released from them. We have also learnt about other component which is the 2n3055 power transistor which we used them in the Darlington pair in the amplifying circuit. Other than hardware, we have used the internet for researching about the project as we mainly used google as a platform. Lastly, this long journey have taught us how to manage the work we had to do and time spent to do the project as a team.

6.2 Impact of Engineering Solutions

Our project has great advantages for each society, environment, and economy. Generating power out free energy is a big deal to us all and it should be the goal of the world. It would cost a lot less money than what it does now and save the environment from pollution when burning coal for example. It would also help the poor society who cannot afford the cost of bills when they can have power out of free energy.

6.3 Contemporary Issues Addressed

As the population increases, the consumption of power increases. The world in general is facing such problem and a solution is needed now or in the near future. This project is the solution for such problem we are facing, where we can produce power out of free energy. It would not costs as much as it does now and it would give great outcomes if engineers took it a step further. It is challenging but that is due to the new principle of it.

7.1 Conclusions

In conclusion, it has been a long and interesting journey for us all. From the start when we picked the topic up to this moment writing the final report. We have had good and bad times putting this project together as we did not get to the goal we had set. On the other hand, we have gained a lot of knowledge with this project. When we first saw the pervious project that was done at PMU, we have set the goal to go for something different and better. As we have explained every aspect about the project in this report, we have partially failed in the last step which is to have enough power to charge a phone, but we have enough knowledge and experience to others who would like to work on such project. As well as the knowledge that we have gained for us using this type of sensors which we worked with for the first time. Not only the sensors but so many components we have worked with for the first time such ultra-capacitors and power transistors.

7.2 Future Recommendations

Our design was what we expected it to be, but the problem was that we have done it on a small scale to introduce this new idea of generating power to the students. If we would recommend, we would recommend to look for better sensors than what we got and have more sensors in number. The only problem

we faced was the time to look for a solution for the low power we have generated. We went with many solutions before thinking of actually the sensors themselves in the beginning and that cost us a lot of time during the semester. That is because the sensors cost a lot of money for students, so we went with something we can afford and learn from. We have learnt that the amplifying circuit cannot go with this system we have built as well as the ultra-capacitors due to the low power we have generated. We would also recommend to have a different design than what we did, for example to put together the sensors in series not in parallel, to place the sensors in a different shape, and to use a different type of weighing machine materials. Also take note of the fact that piezoelectric transducers have very high DC output impedance which causes the power output to be small, so it made our project a lot more challenging and we only found out about this very late in the project.

8. References

- 1- <https://www.elprocus.com/footstep-power-generation-system/> Accessed 10/9/2018
- 2- http://www.ijeit.com/Vol%203/Issue%2010/IJEIT1412201404_51.pdf Accessed 10/9/2018
- 3- <https://circuitdigest.com/electronic-circuits/foot-step-power-generation-circuit-using-piezoelectric-sensor> Accessed 10/9/2018
- 4- https://www.researchgate.net/publication/308120087_Footstep_Power_production_using_Piezoelectric_Sensors Accessed 20/11/2018
- 5- <https://www.ijser.org/researchpaper/Footstep-Voltage-Generator-using-Piezoelectric-Transducers.pdf> Accessed 20/11/2018
- 6- <http://microcontrollerslab.com/foot-step-power-generation-system-using-pic-microcontroller/> Accessed 20/11/2018
- 7- Prince Mohammed bin Fahd university 2015, footstep power generation.
- 8- 8- Alakhawayn university spring 2017, footstep renewed tiles.

Appendix A: Progress Reports

	Project Management: Progress Report	
	Electrical Engineering Department	
	EEEN4311: Design Methodology & Project Management (Fall 2018-19)	
Weeks 1-6	Progress Report No. 1	Date: Su Oct 14, 2018

Project Title		
TEAM	Khalid Al-Hamoudi,201401006	Ahmed Khalid,201402729
	Jubarah Almudhaki,201401010	Azeb Alqahtani,201400530

Tasks	Description (brief but clear)	% Completion
Completed Weeks 1 to 6	1 Planning; Feasibility and Reading	100%
	2 Idea generation and selection	
	3 Project Proposal	
	4 Project management Plan	
	5 Project first presentation	
	6 Select & acquire components for SS1	
In Progress Weeks 7 to 15	7 Design of subsystem 1	100%
	8 Implement Design for SS1	100%
	9 Test and refine design for SS1	100%
	10 Prepare Demo. (prototype)	100%
	11 Prepare Final presentation	100%
	12 Prepare final report	100%
Comments	Buying and waiting for the components to arrive. Researching and meeting with our advisor for more information.	
Deadlines Sundays	ProgRpt1 (Wks 1- 6) Oct 14	ProgRpt3 (Wks 7, 10) Nov 11
	ProgRpt2 (Wks 7, 8) Oct 28	ProgRpt4 (Wks 11, 12) Nov 25

Appendix B: Bill of Materials

Name	Quantity	Price
Various capacitors	7	48
Ultra-capacitors	14	450
Various resistors	20	40
Arduino UNO	1	120
Voltage regulator	2	20
Transistor BC547	2	20
1N4007 diode	5	10
12V Battery lead acid	1	50
LCD screen	1	30
Piezoelectric material	8	150
Weighing machine	1	100
Power transistors	4	20
Other materials		150
Total		1208 SAR

Appendix C: Datasheets

Include only key components and [only main pages](#)

Appendix D: Program Codes

Arduino IDE code:

```
#include <SoftwareSerial.h>
#include <LiquidCrystal.h>
int pizo = A0;

float voltage= 0.0001;
int steps=0;
float raw;

const int rs = 12, en = 11, d4 = 5, d5 =4, d6 = 3, d7 = 2;
LiquidCrystal lcd(rs, en, d4, d5, d6, d7);

int three =9;

void setup() {
  lcd.begin(16, 2);
  lcd.print("  No Signal");
  lcd.setCursor(0,1);
  lcd.print("From Rain Sensor");
  pinMode(pizo,INPUT);

  pinMode(three,OUTPUT);
  Serial.begin(9600);

  analogWrite(three,333);
}

void printlcd()
{
  lcd.begin(16, 2);
  lcd.setCursor(0,0);
  lcd.print("V:");
  lcd.setCursor(3,0);
  lcd.print(voltage,3);
  lcd.setCursor(9,0);
  lcd.print("Stp:");
  lcd.setCursor(13,0);
  lcd.print(steps);
}
```

```
lcd.setCursor(0,1);  
lcd.print(" Step Power Gen.");  
  
}  
void loop() {  
  //Serial.println(analogRead(pizo));  
  raw = analogRead(pizo);  
  voltage = raw/205;  
  steps = raw/4;  
  Serial.println(voltage,3);  
  Serial.println(steps);  
  
  printlcd();  
  delay(300);  
  
}
```

Appendix E: Operation Manual

To use our project all you have to do is provide a power source for the Arduino UNO which can be a 9V battery or using a USB cable and then simply apply mechanical pressure on the piezoelectric sensors and the voltage generated and number of steps applied will be shown on the LCD screen. The load can be connected in parallel with the capacitor in the rectifier circuit, the output voltage can reach up to 5V because that is the limit of the microcontroller, and if it goes higher than that the microcontroller will be damaged. Higher voltage can be obtained but the microcontroller has to be disconnected.