



Prince Mohammad Bin Fahd University

College of Engineering

Department of Civil Engineering

Senior Design Project (ASSE III)

Fall 2015

*Comparative Design & Analysis of a Mosque Using
Steel and Reinforced Concrete*

Presented by:

Hussain Ahmed Alabuo	200900408
Mohammed Essa Alabuo	200900403
Abdullan Nami Alnami	200901322
Mufarreh Mohammed Alshammary	201101147

Supervised by:

Dr. Andi Asiz

Eng. Danish Ahmed

ACKNOWLEDGEMENT

We take this opportunity to express our profound gratitude and deep regards to our supervisors Dr. Andi Asiz and Eng. Danish Ahmed for their exemplary guidance, monitoring and constant encouragement throughout this project. The blessing, help and guidance given by them shall carry us a long way in the journey of life.

We also take this opportunity to express a deep sense of gratitude to the Dean of College of Engineering Dr. Jamal Nayfeh for his cordial support, valuable information and guidance, which helped us in completing our engineering degree.

We would like to thank all faculty members of civil engineering department: Dr. Omar Ouda, Dr. Alaa Salman, and Dr. Abas for the valuable information provided by them in their respective fields. We are grateful for their cooperation during our engineering study.

We would like to thank Almulhim Consulting Engineering represented by Eng. Mohammed Jamal for assisting in the preliminary design of mosque by AutoCAD program which was used as the main drawing for this project.

Lastly, we thank our families, friends and all citizens of Eastern Province for their constant encouragement and help.

ABSTRACT

The Kingdom of Saudi Arabia has been applying the Shari`ah of Islam, acting in accordance with the Holy Qur'an and Sunnah, and making judgments based on Allah's Shari`ah. It also strives to propagate and call people to Islam with wisdom and fair preaching.

This is the essential cornerstone of its system, duties, and obligations, to which it pays due attention. The Basic Law of Saudi Arabia provides for deriving power from the Holy Qur'an and Sunnah, which rule over this Law and all other laws of the Kingdom.

It also stipulates that the Kingdom should protect the Islamic creed, apply the Shari`ah, enjoin good, forbid evil, and call people to Allah.

The Sectors of Islamic Affairs, Da`wah, Guidance, and Endowments have been among the outstanding pillars and essential parts of the Kingdom. Since the foundations of the kingdom were laid by King `Abdul `Aziz Al Saud and his sons after him, the Kingdom has established, sponsored, supported, and developed large organizations for this purpose, flourishing in the era of the Custodian of the Two Holy Mosques, his Crown Prince, and his Second Deputy Prime Minister.

Subsequently wherever the Muslim's have gone, they built Mosques for their needs in that community and worship Allah. Moreover mosque indeed is a great example of traditional and long lasting buildings which civil engineers do best making a strong, stable, and sustainable buildings.

Through our civil engineering study at Prince Mohammed bin Fahd University, as well as taking the opportunity to apply what we have studied at the university level, we decided to choose the design of the mosque. We make Comparative Design & Analysis of a Mosque Using Steel and Reinforced Concrete Elements design and analysis (figure 1), including calculation of the foundation.

Our project covered by several programs such as Etabs2015, Sap2000, AutoCAD, SkiCiv, LimCon, and steel connections.

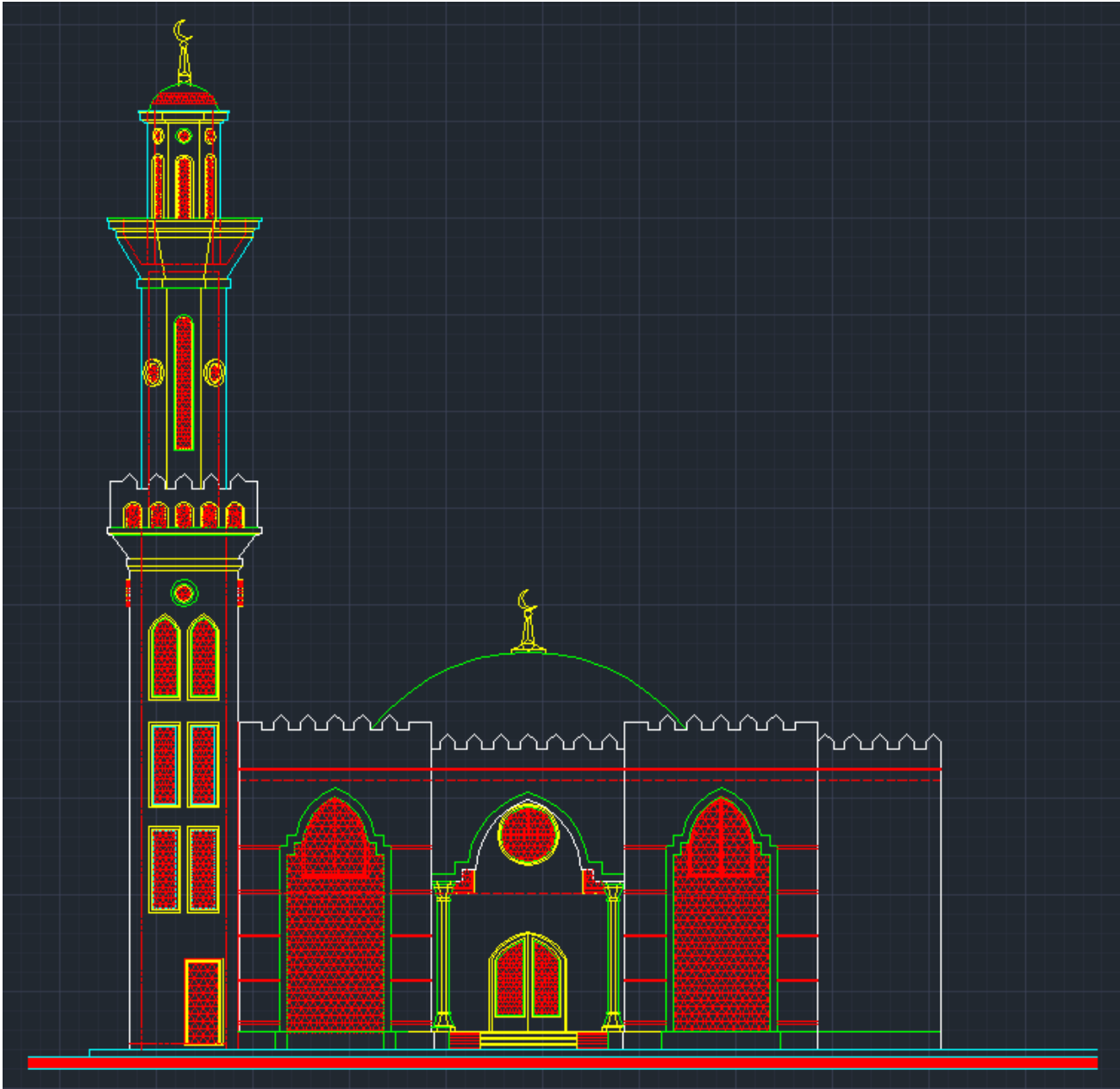

Figure 1 Mosque overview

Table of Contents

ACKNOWLEDGEMENT	2
ABSTRACT	3
Table of Contents	5
Chapter 1: Introduction	10
1.1 General	10
1.2 The main objectives for our project are:	11
1.3 Scope of the report:	11
Chapter 2: Concrete.....	12
2.1 Loads Calculations:	12
2.1.1 Types of loads:.....	12
2.1.2 Load parameters and super imposed dead load:	14
2.1.3 Loads on slabs:	14
2.2: Design of slabs	15
2.2.1 Types of Slab:.....	15
2.2.2 Steps to Design one way slab:	17
2.2.3 Slab Minimum Thickness:.....	17
2.2.4 Materials properties:	17
2.2.5 Load Calculation:	20
2.2.6 Flexural Design.....	21
2.3 Design of beams & sub beams:	26
2.3.1 Steps to Design Rectangular beam & sub beams:	27
2.3.2 Materials properties:	27
2.3.3 Load calculation for sub beam:	27
2.3.4 Design of sub beams:.....	28
2.3.5 Calculations of loads for beam:	39
2.3.6 Design of the beam:.....	40
2.4 Design of columns.....	46
2.4.1 Classification of columns:	46
2.4.3 Materials properties:	49
2.4.4 Load Calculation:	49
2.5 Design of dome	52

2.5.1	Classification of dome:	52
2.5.2	Calculations of dome:	53
Chapter 3: Steel	59
3.1	Introduction:	61
3.2	Design Information:	62
3.2.1	Applicable Design Codes:	62
3.2.2	Material specifications:.....	62
3.2.3	Load Combinations:	63
3.3	Structural Analysis:	64
3.3.1	Mezzanine floor beam (Girder 2-2):.....	65
3.3.2	Roof beam (3DE):	70
3.3.3	Dome beam (3BD):	75
3.3.4	Column (2C):.....	80
3.4	Design:.....	82
3.4.1	Mezzanine beam design (Girder 2-2):	83
3.4.2	Roof beam design (3DE):.....	92
3.4.3	Dome beam design (3BD):.....	101
3.4.4	Column design (2C):	110
3.4.5	ETABS drawings:.....	119
3.5	Connection design:	125
3.5.1	Connection of Mezzanine Floor:	126
3.5.2	Connection of Roof:	140
Chapter 4: Foundation	154
4.1	Introduction	154
4.2	Isolated foundation	154
4.3	Design of Isolated Foundation:	155
Appendix	162
Appendix A:	Analysis & design report using ETABS 2015	162
Appendix B:	Steel design and modeling using ETABS 2015.....	182
References	253

List of figures

Figure 1 Mosque overview	4
Figure 2 One way slab; (a) classification; (b) reinforcement	15
Figure 3 Two way slab.....	16
Figure 4 1st Floor (Mezzanine floor).....	18
Figure 5 Roof Floor	19
Figure 6 Force acting on sub-beam & reaction force	29
Figure 7 Shear force.....	29
Figure 8 Bending moment	30
Figure 9 Deflection	30
Figure 10 (3D) renderer and colored results	31
Figure 11 Force acting on sub-beam & reaction force.	35
Figure 12 Shear force.....	35
Figure 13 Bending moment	36
Figure 14 Deflection	36
Figure 15 (3D) renderer and colored results	37
Figure 16 Force acting on sub-beam & reaction force	41
Figure 17 Shear force.....	41
Figure 18 Bending moment	42
Figure 19 Deflection	42
Figure 20 (3D) renderer and colored results	43
Figure 21 Cross section for eccentrically loaded column.....	46
Figure 22 Column selected for the sample of calculation is 2C Shown in the Figure.....	48
Figure 23 (3D) Dome structural design.	54
Figure 24 (3D) dome overview design.	55
Figure 25 Top view for 1st floor (mezzanine).....	56
Figure 26 Side view for 1st floor (mezzanine)	57
Figure 27 Side view	57
Figure 28 Top view for Roof	58
Figure 29 Front view.....	58
Figure 30 ETABS 3D drawing	64
Figure 31 AutoCAD Drawing, for Grade 2 - Level 7m.....	65
Figure 32 ETABS drawing, mezzanine floor, Girder 2	66
Figure 33 Input data from SkyCiv program for mezzanine floor beam	67
Figure 34 Output data from SkyCiv program (moment)	68
Figure 35 Output data from SkyCiv program (shear).....	69
Figure 36 ETABS drawing, Roof, 3DE.....	71
Figure 37 Input data from SkyCiv program for Roof beam	72
Figure 38 Output data from SkyCiv program (moment)	73
Figure 39 Output data from SkyCiv program (shear).....	74

Figure 40 ETABS drawing, Dome Beam (3BD).....	76
Figure 41 Input data from SkyCiv program for Dome beam.....	77
Figure 42 Output data from SkyCiv program (moment)	78
Figure 43 Output data from SkyCiv program (shear).....	79
Figure 44 ETABS drawing, Column 2C.....	81
Figure 45 Steel section properties (HE 500 B)	88
Figure 46 Steel section properties (HE 400 A).....	97
Figure 47 Steel section properties (IPE 450)	106
Figure 48 Steel section properties (HE 400 B)	115
Figure 49 ETABS 3D model.....	119
Figure 50 Side view	119
Figure 51 Top view for mezzanine floor	120
Figure 52 Top view of sections for mezzanine floor	121
Figure 53 Top view for roof.....	121
Figure 54 Top view of sections for roof	122
Figure 55 Steel stress ratio (column)	123
Figure 56 Steel stress ratio (mezzanine and roof).....	124
Figure 57 Mezzanine Floor plan - Connection	126
Figure 58 Roof plan - Connection	140
Figure 59 Isolated Foundation	154
Figure 60 Foundation thickness and height assumption	156

List of Tables

Table 1 Minimum thickness of one-way solid slabs.....	17
Table 2 Properties	17
Table 3 Design of rectangular beam & sub-beam section for moment (simply supported beam)	26
Table 4 Properties	27
Table 5 Properties	49
Table 6 Material specifications.....	62
Table 7 Dead load	63
Table 8 Live load	63
Table 9 Ultimate load.....	63
Table 10 Mezzanine floor analysis	65
Table 11 Structural analysis for girder 2.....	67
Table 12 Roof analysis for 3DE beam.....	70
Table 13 Structural analysis for 3DE beam	72
Table 14 Roof analysis for dome beam	75
Table 15 Structural analysis for 3BD beam.....	77
Table 16 Structural analysis for column	80
Table 17 Structural analysis for column	81
Table 18 Steel section properties (HE 500 B)	83
Table 19 Steel section properties (HE 400 A)	92
Table 20 Steel section properties (IPE 450)	101
Table 21 Steel section properties (HE 400 B)	110

Chapter 1: Introduction

1.1 General

There are strict and detailed requirements in Sunni fiqh for a place of worship to be considered a mosque, with places that do not meet these requirements regarded as musallas. There are stringent restrictions on the uses of the area formally demarcated as the mosque (which is often a small portion of the larger complex), and, in the Islamic Sharia law, after an area is formally designated as a mosque, it remains so until the Last Day.

Many mosques have elaborate domes, minarets, and prayer halls, in varying styles of architecture. Mosques originated on the Arabian Peninsula, but are now found in all inhabited continents. The mosque serves as a place where Muslims can come together for salat (meaning "prayer") as well as a center for information, education, and dispute settlement. The imam leads the congregation in prayer.

The mosque played a major part in the spread of education in the Muslim World, and the association of the mosque with education remained one of its main characteristics throughout history, and, the school became an indispensable appendage to the mosque. From the earliest days of Islam, the mosque was the center of the Muslim community, a place for prayer, meditation, religious instruction, political discussion, and a school. And anywhere Islam took hold, mosques were established, and basic religious and educational instruction began. Once established, mosques developed into well-known places of learning, often with hundreds, even thousands, of students, and frequently contained important libraries. In Iraq, pharmacology, engineering, astronomy and other subjects were taught in the mosques of Baghdad, and students came from Syria, Persia and India to learn these sciences. While at the Qarawiyyin Mosque, there were courses on grammar, rhetoric, logic, mathematics, and astronomy, and possibly history, geography and chemistry.

1.2 The main objectives for our project are:

- 1- To apply all theories that have been learned "in all structural courses" to this Project.
- 2- To learn how to design a building from A to Z and passing through all design stages.
- 3- To be familiar with other elements that is used in real life and wasn't learned in the courses.

Codes in practice:

- 1- American Concrete Institute (ACI 318-08) code.
- 2- Saudi Building Code. SBC.
- 3- International Building Code UBC-1997.
- 4- Minimum Design Loads for Buildings and Other Structures ASCE_7-10

The materials used, in this project include steel, concrete and foundation with the following properties:

- 1- $F_y = 420$ MPa steel.
- 2- $f'_c = 30$ MPa concrete (Slab, beam).
- 3- $F'_c = 40$ MPa concrete.(column and shear wall)

The building will be planted on a soil with 450 KPa bearing capacity.

1.3 Scope of the report:

The present report is composed of five chapters. A detailed description of the project and a historical background is presented in chapter 1. The concrete design is introduced in chapter 2 including floors, beams, dome, and columns. Following that, the steel design with connections are given in chapter 3. The foundation design discussed in chapter 4.

Chapter 2: Concrete

2.1 Loads Calculations:

2.1.1 Types of loads:

Structural loads are forces applied to a component of a structure or to the structure as a unit.

In structural design, assumed loads are specified international and local design codes for types of structures, geographic locations, and usage. In addition to the load magnitude, its frequency of occurrence, distribution, and nature (static or dynamic) are important factors in design. Loads cause stresses, deformation in structures. Assessment of their effects is carried out by the methods of structural analysis. Excess load or overloading may cause structural failure, and hence such possibility should be either considered in the design or strictly controlled.

In the Euro codes, the term actions have a similar meaning to loads, but encompass applied deformations as well as forces.

The following lists the common loading types primarily for civil infrastructure and land machinery. Structures for aerospace (e.g. aircraft, satellites, rockets, space stations, etc...) and marine environments (e.g. boats, submarines, etc.) have their own particular design loads and consideration includes dead loads but also includes forces set up by irreversible changes in a structure's constraints - for example, loads due to settlement, the secondary effects of pre-stress or due to shrinkage and creep in concrete.

A. Dead Load

The dead load is the weight of the structure acting with gravity on the foundations below. Snow load is the weight of the dead load and the imposed load but also the weight of the snow on top which could cause damage to the roof.

B. Live Loads

Live loads, or imposed loads, are temporary, of short duration, or moving. Examples include snow, wind, earthquake, traffic, movements, water pressures in tanks, and occupancy loads. For certain specialized structures, vibro-acoustic loads may be considered.

C. Environmental Loads

- Temperature changes leading to thermal expansion cause thermal loads
- loads caused by humidity or moisture induced expansion
- Water waves
- Shrinkage

D. Static Loads

These are loads that build up gradually over time, or with negligible dynamic effects. Since structural analysis for static loads is much simpler than for dynamic loads, design codes usually specify statically-equivalent loads for dynamic loads caused by wind, traffic or earthquake

E. Dynamic Loads

These are loads that display significant dynamic effects. Examples include impact loads, waves, wind gusts and strong earthquakes. Because of the complexity of analysis, dynamic loads are normally treated using statically equivalent loads for routine design of common structures. Dynamic loads are also caused by a force other than gravity.

F. Load Combinations

A load combination results when more than one load type acts on the structure. Design codes usually specify a variety of load combinations together with weighting factors for each load type in order to ensure the safety of the structure under different probable loading scenarios.

- **The Load Combination Equations as per ACI 318 M- 08:**

1. $1.4(D + F)$
2. $1.2(D + F + T) + 1.6(L + H) + 0.5(L_r \text{ or } S \text{ or } R)$
3. $1.2D + 1.6(L_r \text{ or } S \text{ or } R) + ((0.5 \text{ or } 1.0)^*L \text{ or } 0.8W)$
4. $1.2D + 1.6W + (0.5 \text{ or } 1.0)^*L + 0.5(L_r \text{ or } S \text{ or } R)$
5. $1.2D + 1.0E + (0.5 \text{ or } 1.0)^*L + 0.2S$
6. $0.9D + 1.6W + 1.6H$
7. $0.9D + 1.0E + 1.6H$

2.1.2 Load parameters and super imposed dead load:

A. Load parameters according to ACI & SBC code:

- Ceramic tiles thickness = 0.03 m.
- Ceramic tiles density = 23.5 kN / m³.
- Density of RC = 24.525 kN / m³.
- Slabs thickness = 0.25 m.

B. Super imposed dead load:

- Ceramic tiles = 0.03 * 23.5 = 0.705 kN/m².
- Concrete = 24.525 * 0.25 = 6.13125 kN/m².

2.1.3 Loads on slabs:

Since our design have roof and one floor (Mezzanine floor) so we will have two different LL (live load).

a) 1st Floor (Mezzanine floor)

Equivalent L.L (SBC 301 table 4-1) = 5 kN/m².

b) Roof

Equivalent L.L (SBC 301 table 4-1) = 2.5 kN/m²

2.2: Design of slabs

2.2.1 Types of Slab:

Introduction:

Reinforced concrete slab is used to provide flat, useful surface. It might be supported either by beam or directly by column. Slabs might be classified to one way or two way slab depending on the deflection shape of slab as shown on the figures 2.1 and 2.2.

The selection of the system of slab used in the structure is depending on the architectural plan and the construction requirement and the economy.

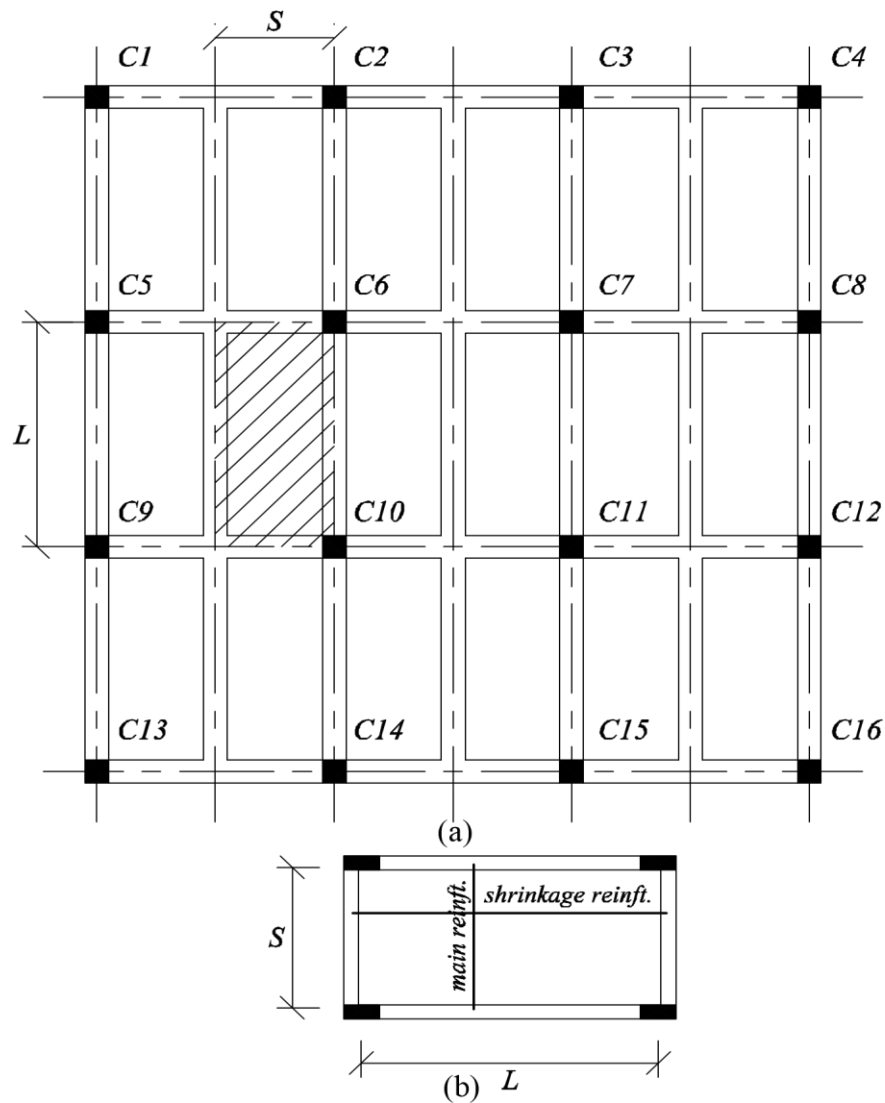

Figure 2 One way slab; (a) classification; (b) reinforcement

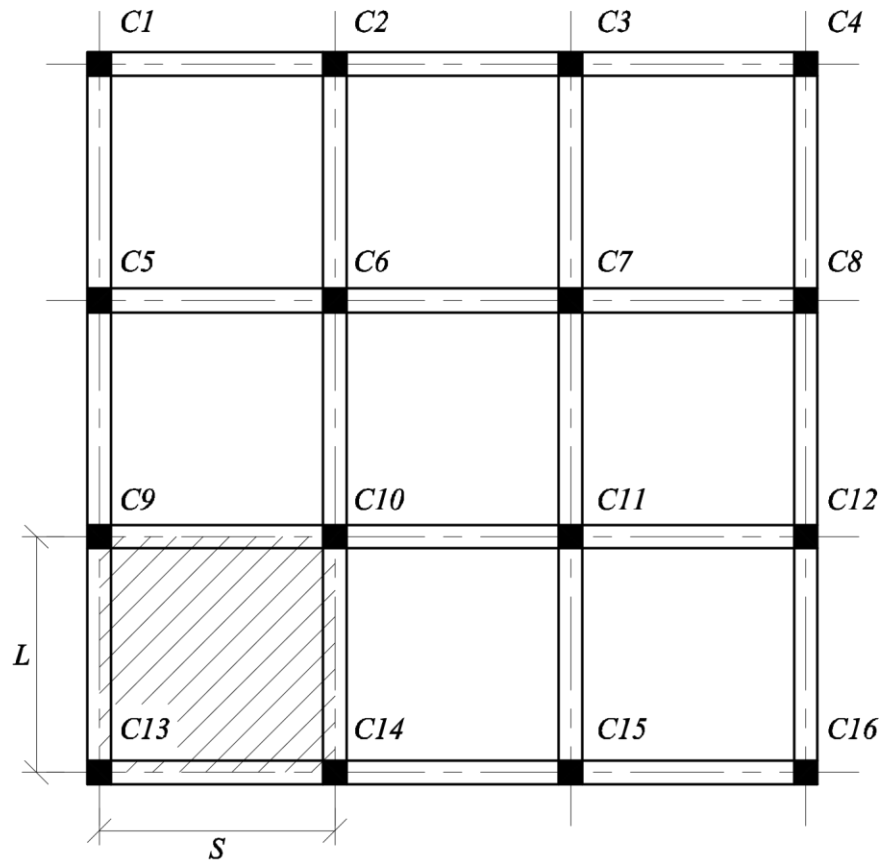

Figure 3 Two way slab

To know which type is our slab we need to calculate it:

Design of Slab	
Type of Slab	
$L_y / L_x = 6/3 = 2 \geq 2$	
It's a One way Slab	
	Ly= 6m
	Lx= 3m

2.2.2 Steps to Design one way slab:

- Step 1: Determine the minimum required thickness of slab from table 9.5(c) ACI 318
- Step 2: Determine the ultimate loads that effect on the slab.
- Step 3: Determine the total factored static moment.
- Step 4: Determine the required area of steel with the required spacing.

2.2.3 Slab Minimum Thickness:

Table 1 Minimum thickness of one-way solid slabs

Element	Simply supported	One end continuous	Both ends continuous	Cantilever
One-way solid slabs	$l/20$	$l/24$	$l/28$	$l/10$

Where l is the span length in the direction of bending.

Minimum thickness of one-way slabs.			
Both ends Continuous.			
One-way solid slab = $L/28$			
where L is the span length in the direction of binding.			
	L		Total
$L/28 =$	236.592	$\div 28 =$	8.449714 in
$8.449714 \text{ in} = 0.21572 \text{ m} \approx 0.25 \text{ m thickness of slabs}$			

2.2.4 Materials properties:

Table 2 Properties

concrete	f_c'	30 MPa
steel	F_y	420 MPa

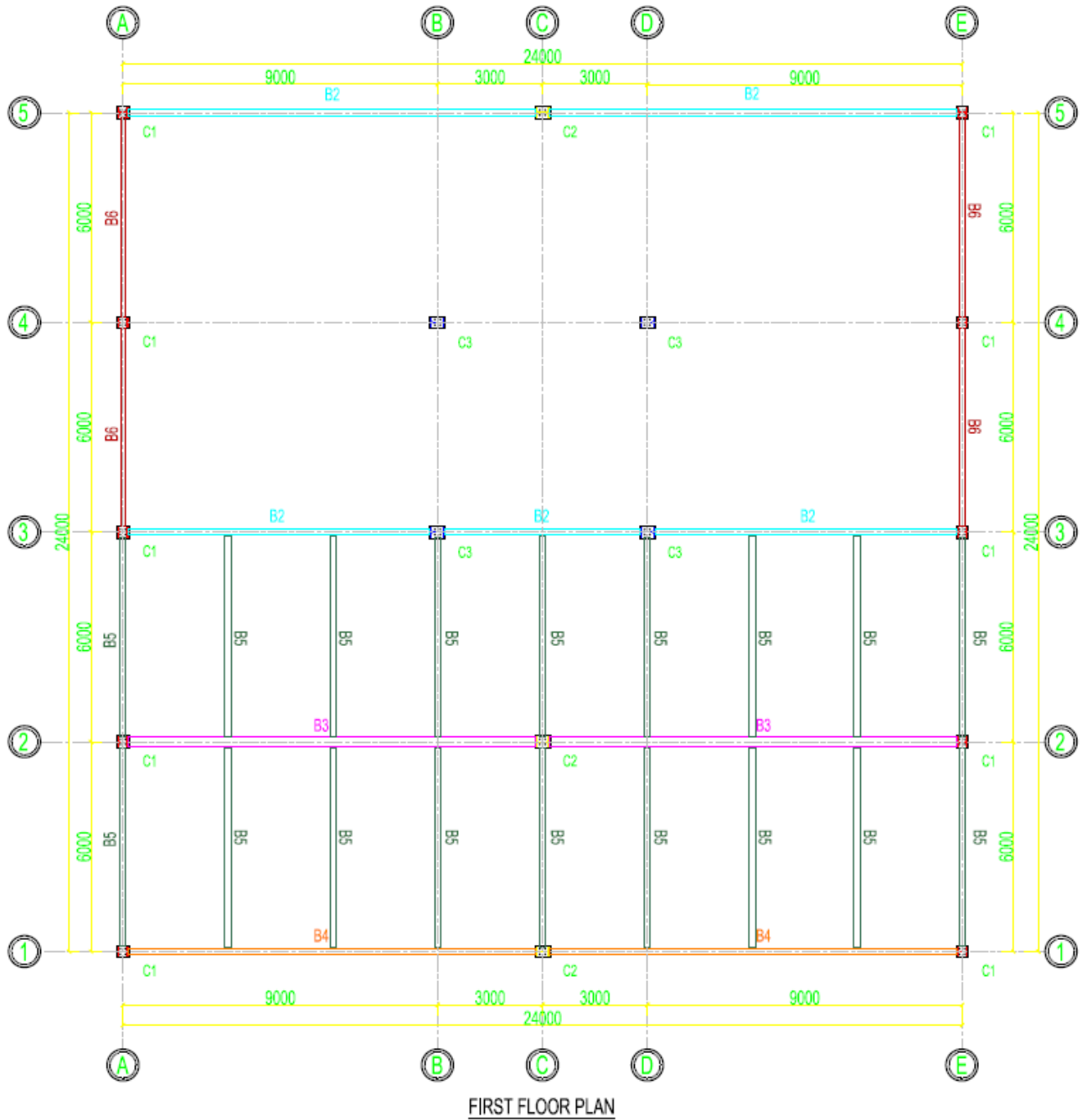
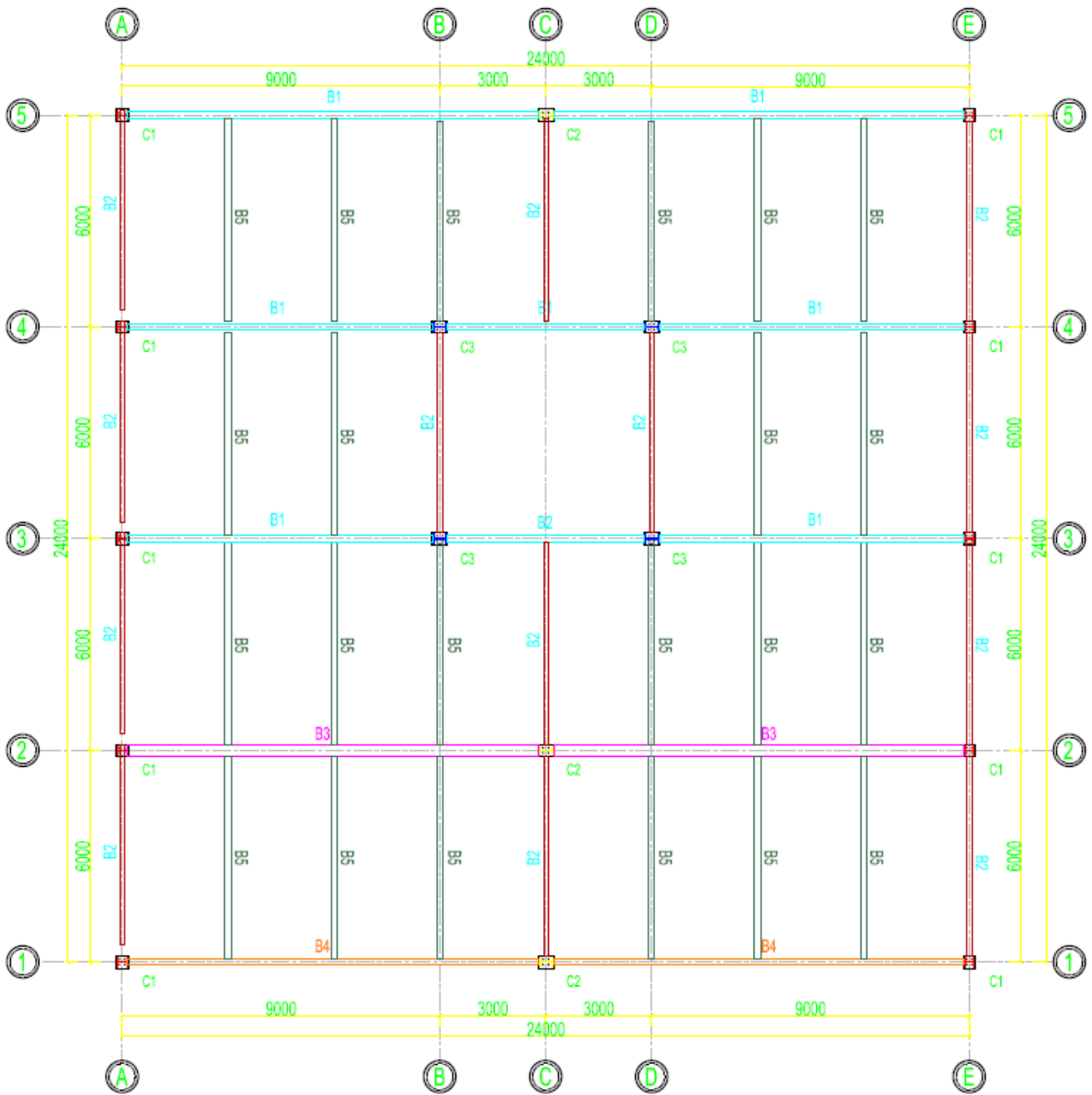

Figure 4 1st Floor (Mezzanine floor)



SECOND FLOOR PLAN

Figure 5 Roof Floor

2.2.5 Load Calculation:

a) 1st Floor (Mezzanine floor) loads:

First Floor (Mezzanine)				
Loads				
Dead Load:				
Ceramic Tiles:				
D=kN/m ³	Th=m	Total		
23.5	× 0.03	= 0.705 kN/m ²		
Concrete:				
D=kN/m ³	Th=m	Total		
24.525	× 0.25	= 6.13125 kN/m ²		
Total Dead Load:				
	Ceramic	Concrete	Total	
	0.705	× 6.13125	= 6.83625 kN/m ²	
Live Load:				
Live Load =		5 kN/m ²		
Ultimate Load:				
WU = 1.2 x DL + 1.6 x LL				Total
1.2	×	6.83625	+ 1.6	× 5 = 16.2035 kN/m ²

Saudi Building Code, 301 Structural – Loading and Forces
CHAPTER 4: LIVE LOADS

b) Roof Floor loads:

Design of Slab			
Loads			
Roof Floor			
Dead Load:			
Concrete:			
D=kN/m ³	Th =m	Total	
24.525	× 0.25	= 6.13125 kN/m ²	
Live Load:			
Live Load =		2.5 kN/m ²	
Ultimate Load:			
WU = 1.2 x DL + 1.6 x LL			Total
1.2	×	6.13125	+ 1.6 × 2.5 = 11.3575 kN/m ²

Saudi Building Code, 301 Structural – Loading and Forces
CHAPTER 4: LIVE LOADS

2.2.6 Flexural Design

The total factored static moment M_u is given by:

$$M_u = \frac{W_u l_2 l_n^2}{8}$$

Where W_u = factored load per unit area, L_2 length of span, measured center to center of supports in the direction perpendicular to the direction moments are being determined , and L_n =is the average of adjacent clear span length.

a) 1st Floor (Mezzanine floor) design:

Design of Slab					
One way Slab					
Floor Slab					
Yield point of the Steel $F_y = 60000 \text{ psi} = 60 \text{ ksi.}$					
More than two spans.				$L_n = 6\text{m}$	
$M_u = \frac{W_u * L_2 * L_n^2}{8}$					
				$L_2 = 3\text{m}$	
$W_u =$	16.2035	kN/m^2	\rightarrow	$= 0.338491$	kip/ft^2
				Total	
$M_u =$	$\frac{16.204 \times 3 \times 36}{8}$		\rightarrow	$= 218.7473$	$\text{kN-m} \rightarrow 397.5777 \text{ kip-in}$

Area of Steel					
$L_a = 0.9 \times H$		H		Total	
$L_a =$	0.9	\times	10	$=$	9 in
$A_s = \frac{M_u}{0.9 * f_y * l_a}$					
$A_s =$	$\frac{397.5777}{0.9 \times 60 \times 9}$		\rightarrow	Total	0.818061 in^2
$A_s \text{ min} =$	$\frac{200}{F_y}$		Total		
	$\frac{200}{60000}$		$=$	0.0033 in^2	
$A_s \text{ max} = 0.75 \times A_{sb}$					
$A_{sb} = N_{cb} / F_y$					
$N_{cb} = 0.85 * f_c * a_b * b$					
$\frac{C_b}{0.003} = \frac{L_a - C_b}{0.00207}$					
from the formula above we get $C_b = 5.4 \text{ in}$					
$a = \beta * C_b \rightarrow \beta = 0.85 \text{ for } f_c \leq 4000 \text{ psi}$					
$a =$	0.85×5.4	$=$	4.59		in
$b =$	1 ft	\rightarrow	12 in		(assuming)
$N_{cb} =$	$0.85 \times 4000 \times 4.59 \times 12$	$=$	187272	$\text{Ib/in}^2 \rightarrow$	187.272 Klb
$A_{sb} =$	187.272×60	$=$	3.1212		in^2
$A_s \text{ max} =$	0.75×3.1212	$=$	2.3409		in^2
we will use A_s as the area of steel bars = 0.818061 in^2					

Design of steel bars in Floor slab									
we will use A_s as the area of steel bars =					0.818061 in ²				
Use the table to Find the Number of Bars and Diameter of bars									
Table 2.3 Areas of Multiple of Reinforcing Bars (in ²)									
Number of bars	Bar number								
	#3	#4	#5	#6	#7	#8	#9	#10	#11
1	0.11	0.20	0.31	0.44	0.60	0.79	1.00	1.27	1.56
2	0.22	0.40	0.62	0.88	1.20	1.58	2.00	2.54	3.12
3	0.33	0.60	0.93	1.32	1.80	2.37	3.00	3.81	4.68
4	0.44	0.80	1.24	1.76	2.40	3.16	4.00	5.08	6.24
5	0.55	1.00	1.55	2.20	3.00	3.95	5.00	6.35	7.80
6	0.66	1.20	1.86	2.64	3.60	4.74	6.00	7.62	9.36
7	0.77	1.40	2.17	3.08	4.20	5.53	7.00	8.89	10.92
8	0.88	1.60	2.48	3.52	4.80	6.32	8.00	10.16	12.48
9	0.99	1.80	2.79	3.96	5.40	7.11	9.00	11.43	14.04
10	1.10	2.00	3.10	4.40	6.00	7.90	10.00	12.70	15.60
Take 2#6 Ø				→		2 No. 6 bars			

b) Roof design:

Design of Slab												
One way Slab												
Roof Slab												
Yield point of the Steel												
Fy = 60000 psi = 60 ksi.												
More than two spans.					Ln = 6m							
$M_u = \frac{W_u * L_2 * L_n^2}{8}$												
Where Ln is the average of adjacent clear span length.					L2 = 3m							
Wu =	11.3575	kN/m ²	→	=	0.237258	kip/ft ²						
Mu =	11.358	×	3	×	36	→	=	153.3263	kN-m	→	278.6737	kip-in
Total												

Area of Steel					
$La = 0.9 \times H$			H		Total
$La =$	0.9	\times	10	$=$	9 in
$A_s = \frac{Mu}{0.9 \times fy \times la}$					
$A_s =$	$\frac{278.6737}{0.9 \times 60 \times 9}$	\rightarrow	$=$	Total 0.573403 in^2	
$A_s \text{ min} =$	$\frac{200}{Fy}$	Total			
	$\frac{200}{60000}$	$= 0.0033 \text{ in}^2$			
$A_s \text{ max} =$	$0.75 \times A_{sb}$				
	$A_{sb} = N_{cb} / Fy$				
	$N_{cb} = 0.85 \times f_c \times a_b \times b$				
	$\frac{Cb}{0.003} = \frac{La - Cb}{0.00207}$				
from the formula above we get $Cb = 5.4 \text{ in}$					
$a = \beta \times Cb$	$\rightarrow \beta = 0.85 \text{ for } f_c \leq 4000 \text{ psi}$				
$a =$	0.85×5.4	$=$	4.59 in		
$b =$	1 ft	\rightarrow	12 in	(assuming)	
$N_{cb} =$	$0.85 \times 4000 \times 4.59 \times 12$	$=$	187272 Ib/in^2	\rightarrow	187.272 Klb
$A_{sb} =$	$\frac{187.272}{60}$	$=$	3.1212 in^2		
$A_s \text{ max} =$	0.75×3.1212	$=$	2.3409 in^2		
we will use A_s as the area of steel bars = 0.573403 in^2					

Design of steel bars in Roof slab	
we will use A_s as the area of steel bars =	0.573403 in^2
Use the table to Find the Number of Bars and Diameter of bars	

Table 2.4 Areas of Multiple of Reinforcing Bars (in²)

Number of bars	Bar number								
	#3	#4	#5	#6	#7	#8	#9	#10	#11
1	0.11	0.20	0.31	0.44	0.60	0.79	1.00	1.27	1.56
2	0.22	0.40	0.62	0.88	1.20	1.58	2.00	2.54	3.12
3	0.33	0.60	0.93	1.32	1.80	2.37	3.00	3.81	4.68
4	0.44	0.80	1.24	1.76	2.40	3.16	4.00	5.08	6.24
5	0.55	1.00	1.55	2.20	3.00	3.95	5.00	6.35	7.80
6	0.66	1.20	1.86	2.64	3.60	4.74	6.00	7.62	9.36
7	0.77	1.40	2.17	3.08	4.20	5.53	7.00	8.89	10.92
8	0.88	1.60	2.48	3.52	4.80	6.32	8.00	10.16	12.48
9	0.99	1.80	2.79	3.96	5.40	7.11	9.00	11.43	14.04
10	1.10	2.00	3.10	4.40	6.00	7.90	10.00	12.70	15.60
Take 1#7 Ø		\rightarrow		1 No. 7 bars					

Find the actual La							
						Prefixes	
Actual d = h - Cover - stirrup - $\frac{d_b}{2}$						h =	10 in
						$d_b =$	1
La = 0.9 x H			Total				
La =	0.9	×	10 in	=	9	in	
							1
Actual d =	10	-	1.50	-	0	-	$\frac{1}{2}$ = 8 in
							2

Table 2.5 Minimum Required Beam Width, *b* (in.)

Number of bars	Bar number							
	# 3 and #4	#5	#6	#7	#8	#9	#10	#11
2	6.0	6.0	6.5	6.5	7.0	7.5	8.0	8.0
3	7.5	8.0	8.0	8.5	9.0	9.5	10.5	11.0
4	9.0	9.5	10.0	10.5	11.0	12.0	13.0	14.0
5	10.5	11.0	11.5	12.5	13.0	14.0	15.5	16.5
6	12.0	12.5	13.5	14.0	15.0	16.5	18.0	19.5
7	13.5	14.5	15.0	16.0	17.0	18.5	20.5	22.5
8	15.0	16.0	17.0	18.0	19.0	21.0	23.0	25.0
9	16.5	17.5	18.5	20.0	21.0	23.0	25.5	28.0
10	18.0	19.0	20.5	21.5	23.0	25.5	28.0	31.0

Find the actual b	
from the As we will find the actual b after we assume it 12 in	
Take 3#8 Ø	→ from table 5. the minimum width b = 9 in

2.3 Design of beams & sub beams:

- Introduction:**

Beams are the structural elements that carry the transferred loads from the slabs; they are treated as the slab's supports.

- Beams types according to the reinforcement are:**

1. Simply supported - a beam supported on the ends which are free to rotate and have no moment resistance.
2. Fixed - a beam supported on both ends and restrained from rotation.
3. Over hanging - a simple beam extending beyond its support on one end.
4. Double overhanging - a simple beam with both ends extending beyond its supports on both ends.
5. Continuous - a beam extending over more than two supports.
6. Cantilever - a projecting beam fixed only at one end.
7. Trussed - a beam strengthened by adding a cable or rod to form a truss.

Table 3 Design of rectangular beam & sub-beam section for moment (simply supported beam)

	$\theta_1 = \theta_2 = \frac{Pl^2}{16EI}$	$y = \frac{Px}{12EI} \left(\frac{3l^2}{4} - x^2 \right) \text{ for } 0 < x < \frac{l}{2}$	$\delta_{max} = \frac{Pl^3}{48EI}$
7. Beam Simply Supported at Ends – Concentrated load P at any point			
	$\theta_1 = \frac{Pb(l^2 - b^2)}{6EI}$ $\theta_2 = \frac{Pab(2l - b)}{6EI}$	$y = \frac{Pbx}{6EI} (l^2 - x^2 - b^2) \text{ for } 0 < x < a$ $y = \frac{Pb}{6EI} \left[\frac{l}{b} (x - a)^3 + (l^2 - b^2) x - x^3 \right]$ <p style="text-align: center;">for $a < x < l$</p>	$\delta_{max} = \frac{Pb(l^2 - b^2)^{3/2}}{9\sqrt{3}EI} \text{ at } x = \sqrt{(l^2 - b^2)}/\sqrt{3}$ $\delta = \frac{Pb}{48EI} (3l^2 - 4b^2) \text{ at the center, if } a > b$
8. Beam Simply Supported at Ends – Uniformly distributed load ω (N/m)			
	$\theta_1 = \theta_2 = \frac{\omega l^3}{24EI}$	$y = \frac{\omega x}{24EI} (l^3 - 2lx^2 + x^3)$	$\delta_{max} = \frac{5\omega l^4}{384EI}$
9. Beam Simply Supported at Ends – Couple moment M at the right end			
	$\theta_1 = \frac{MI}{6EI}$ $\theta_2 = \frac{MI}{3EI}$	$y = \frac{Mlx}{6EI} \left(1 - \frac{x^2}{l^2} \right)$	$\delta_{max} = \frac{MI^2}{9\sqrt{3}EI} \text{ at } x = \frac{l}{\sqrt{3}}$ $\delta = \frac{MI^2}{16EI} \text{ at the center}$
10. Beam Simply Supported at Ends – Uniformly varying load: Maximum intensity ω_a (N/m)			
	$\theta_1 = \frac{7\omega_a l^3}{360EI}$ $\theta_2 = \frac{\omega_a l^3}{45EI}$	$y = \frac{\omega_a x}{360EI} (7l^3 - 10l^2 x^2 + 3x^4)$	$\delta_{max} = 0.00652 \frac{\omega_a l^4}{EI} \text{ at } x = 0.519l$ $\delta = 0.00651 \frac{\omega_a l^4}{EI} \text{ at the center}$

2.3.1 Steps to Design Rectangular beam & sub beams:

- Step 1: Determine the minimum required depth of beam & sub beam from table 4.1 ACI 318 code then compute the width.
- Step 2: Determine the ultimate load that effect on the beam & sub beam.
- Step 3: Determine the total factored static moment.
- Step 4: Determine the required area of steel for flexural design.
- Step 5: check the ductility.
- Step 6: Determine the required area of stirrups for the shear.

2.3.2 Materials properties:

Table 4 Properties

concrete	f_c'	30 MPa
steel	F_y	420 MPa

2.3.3 Load calculation for sub beam:

a) Load of Sub beam for 1st floor (mezzanine floor):

Sub Beam of floor						
Loading						
Loading on Floor =			$W_u \times Spacing =$			Total
		16.2035	kN/m ²	×	3 m	= 48.6105 kN/m

b) Load of Sub beam for Roof:

Sub Beam of Roof						
Loading						
Loading on Roof =			$W_u \times Spacing =$			Total
		11.3575	kN/m ²		3 m	34.0725 kN/m

2.3.4 Design of sub beams:

a) Design of Sub beam for 1st floor (mezzanine floor):

TABLE 2.8 Minimum Thickness of Nonprestressed Beams or One-Way Slabs Unless Deflections Are Computed^{1,2}

Member	Minimum Thickness, <i>h</i>			
	Simply supported	One end continuous	Both ends continuous	Cantilever
	Members not supporting or attached to partitions or other construction likely to be damaged by large deflections			
Solid one-way slabs	$l/20$	$l/24$	$l/28$	$l/10$
Beams or ribbed one-way slabs	$l/16$ ←	$l/18.5$	$l/21$	$l/8$

Beam Weight							
Length =	6 m						
1- Find Depth of Beam (h) =	$L/16 =$	7.38 in	≈	8 in	=	203 mm	
2- Find Width of Beam (b) =	$h/2 =$	3.69 in	≈	4 in	=	102 mm	
3- Self weight of Beam (Bw) =	$b \times h \times \text{Density} =$			8 in	4 in	150 lb/ft ³	
			→	0.667 ft	×	0.333 ft	× 150 lb/ft ³ = 33.33 lb/ft
convert	33.33 lb/ft	→	≈	0.04518 kN/m			
$W_{ub} =$	0.04518	×	1.2	=	0.054216 kN/m		
4- reaction force acting on beam:							
	$\frac{W \cdot L}{2} + \frac{P}{2}$				$h =$	203 mm	
R1 =	24.467898 kN						
R2 =	24.467898 kN						
						$b =$	102 mm
5- moment:							
$\frac{WL^2}{8} + \frac{PL}{4}$	→	0.054216	×	36 m	+	6 m	= 73.159722 kN/m
				8		4	
moment formula from steel book from moments table 3-23							

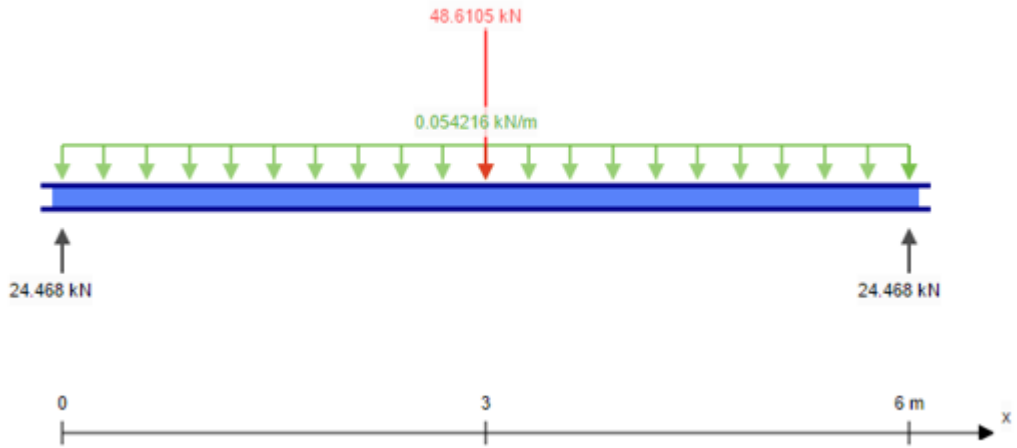

Figure 6 Force acting on sub-beam & reaction force

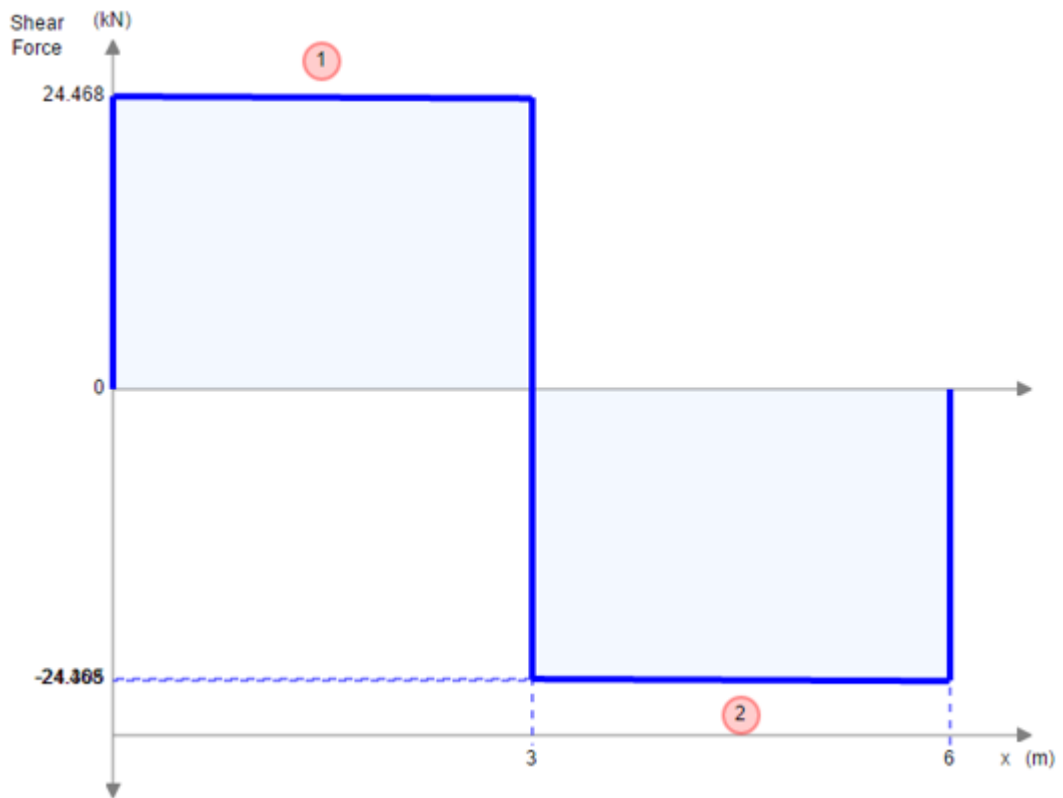

Figure 7 Shear force

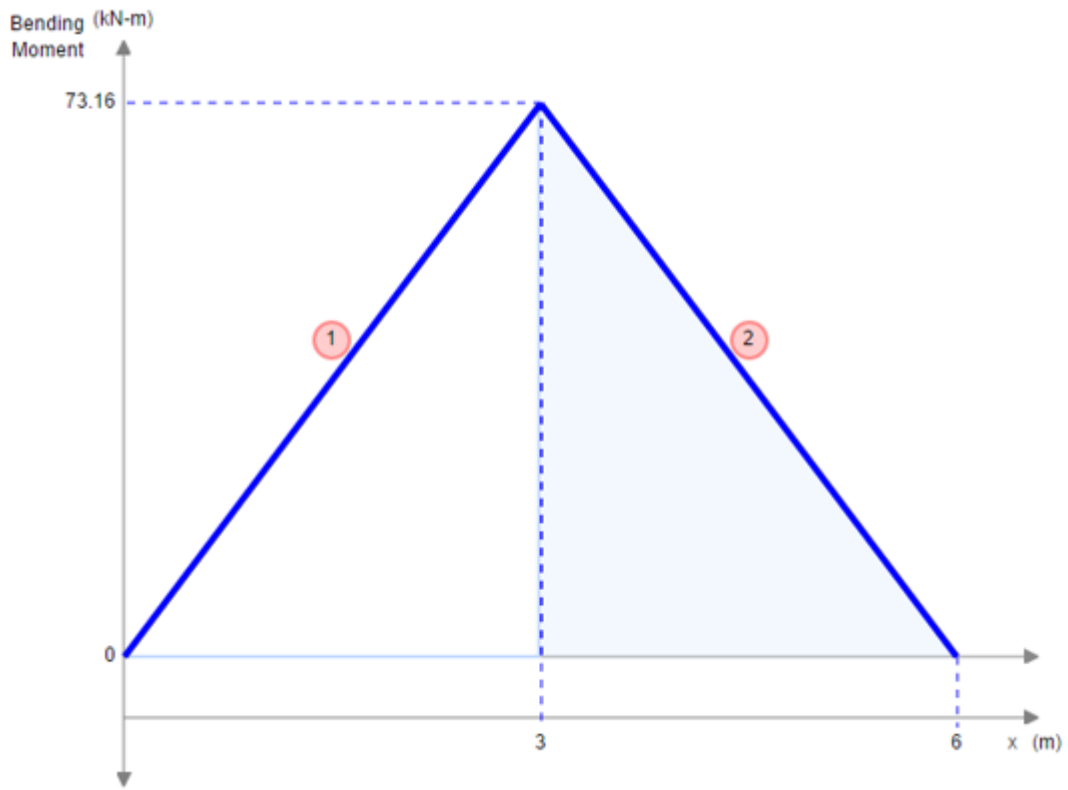

Figure 8 Bending moment

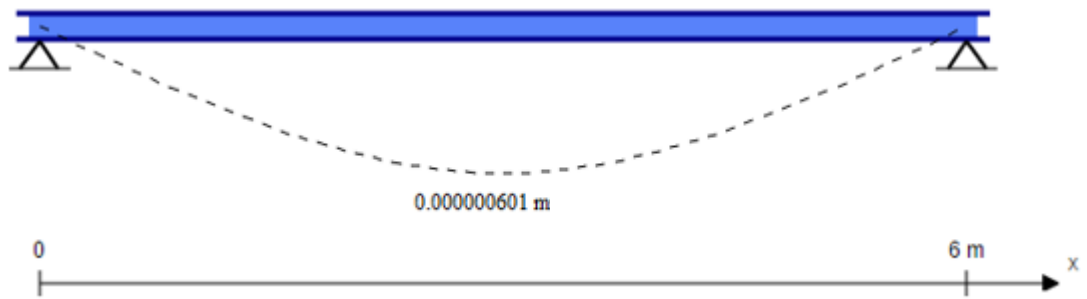

Figure 9 Deflection

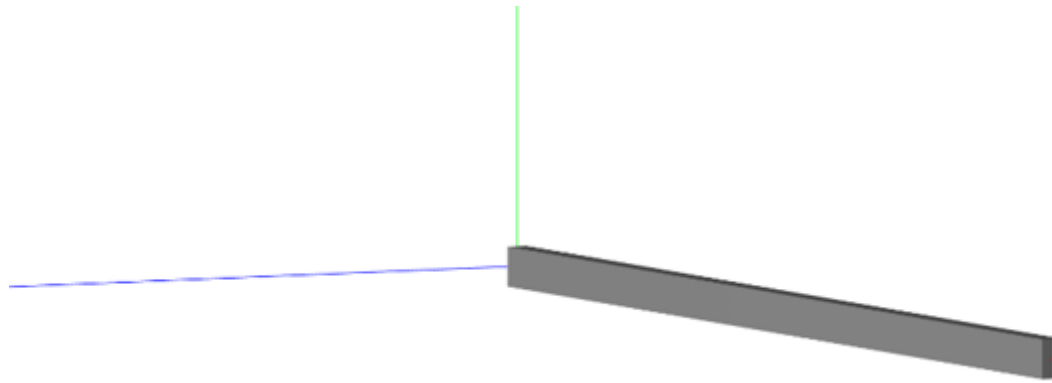

Figure 10 (3D) renderer and colored results

Area of Steel									
$La = 0.9 \times H$		H		$Total$					
$La =$	0.9	\times	8	$=$	7.2	in			
$A_s = \frac{Mu}{0.9 \times fy \times la}$					$Mu =$	73.159722	$kN/m \rightarrow \approx$	132.9693239	$kip-in$
$A_s =$	$\frac{132.9693239}{0.9 \times 60 \times 7.2}$				\rightarrow	$Total$		$0.34199929 in^2$	
$A_s \min =$	$\frac{200}{Fy}$		$Total$						
	200	\div	60000	$=$	0.0033		in^2		
$A_s \max =$	$0.75 \times A_{sb}$								
$A_{sb} = N_{cb} / Fy$									
$N_{cb} = 0.85 \times f_c \times a_b \times b$									
$\frac{Cb}{0.003} = \frac{La - Cb}{0.00207}$									
from the formula above we get $Cb = 5.4 in$									
$a = \beta \times Cb$	$\rightarrow \beta = 0.85 \text{ for } f_c \leq 4000 \text{ psi}$								
$a =$	0.85	\times	5.4	$=$	4.59	in			
$b =$	1 ft	\rightarrow		$12 in$		(assuming)			
$N_{cb} =$	0.85	\times	4000	\times	4.59	\times	12	$=$	$187272 \text{ lb/in}^2 \rightarrow 187.272 \text{ Klb}$
$A_{sb} =$	187.272	\times	60	$=$	3.1212		in^2		
$A_s \max =$	0.75	\times	3.1212	$=$	2.3409		in^2		
we will use A_s as the area of steel bars =					$0.34199929 in^2$				

Use the table to Find the Number of Bars and Diamater of bars

Table 2.9 Areas of Multiple of Reinforcing Bars (in²)

Number of bars	Bar number								
	#3	#4	#5	#6	#7	#8	#9	#10	#11
1	0.11	0.20	0.31	0.44	0.60	0.79	1.00	1.27	1.56
2	0.22	0.40	0.62	0.88	1.20	1.58	2.00	2.54	3.12
3	0.33	0.60	0.93	1.32	1.80	2.37	3.00	3.81	4.68
4	0.44	0.80	1.24	1.76	2.40	3.16	4.00	5.08	6.24
5	0.55	1.00	1.55	2.20	3.00	3.95	5.00	6.35	7.80
6	0.66	1.20	1.86	2.64	3.60	4.74	6.00	7.62	9.36
7	0.77	1.40	2.17	3.08	4.20	5.53	7.00	8.89	10.92
8	0.88	1.60	2.48	3.52	4.80	6.32	8.00	10.16	12.48
9	0.99	1.80	2.79	3.96	5.40	7.11	9.00	11.43	14.04
10	1.10	2.00	3.10	4.40	6.00	7.90	10.00	12.70	15.60

Take 2#4 Ø	→	2 No. 4 bars
------------	---	--------------

Shear					
$V_v = R - W_{ub} * (h')$					
$h' = 2 * b$					
$V_v =$	24.468	-	0.054 *	(6 m - 5.8 m) =	24.457 kN
$V_v = \phi V_c + V_s$					
$V_c = 2 \phi \sqrt{f'_c} b w d$					
$V_c =$	2	*	0.85 *	$\sqrt{4351.131} * 4 * 8$	= 3588.3928 lb
3588.3928 lb	→	1628.127414 kg	→	15955.64866 N	→ 15.9556 kN
V_s	→	$\frac{24.457}{0.850}$		$\frac{15.9556}{0.850}$	= 10.00165428 kN
from V_s calculate stirrups :					
$S = \frac{A_v * f_y * d}{V_s}$					
$S =$	0.220		4000	$\frac{7.20}{10.02}$	= 632.335 in
according to ACI the spacing of shear reinforcement should not be longer of the smaller of the following :					
①	$d/2$	8 in	× 2	= 4 in	→ = 102mm
②	$\frac{A_v f_y}{50 b w}$	0.220	× 60	= 0.033 in	
		50	× 8 in		

Find the actual La					
Actual d = h - Cover - stirrup - $\frac{d_b}{2}$					
$La = 0.9 \times H$					
$La =$	0.9	×	8 in	=	7.2 in
Actual d =	8	-	1.50	-	$\frac{1}{2} = 0.5$
					= 6 in

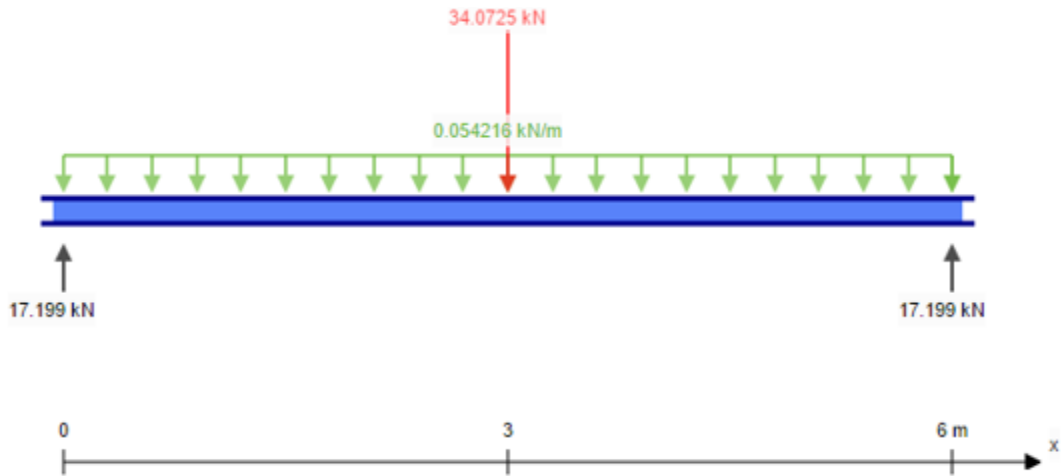

Figure 11 Force acting on sub-beam & reaction force.

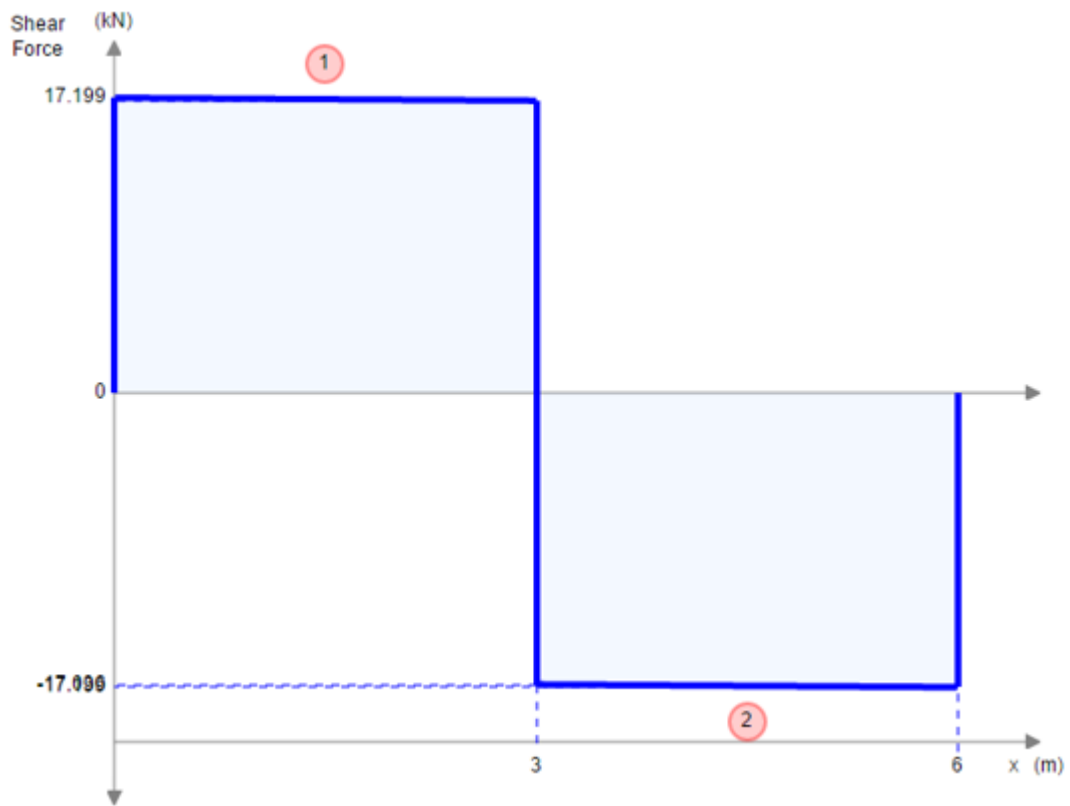

Figure 12 Shear force

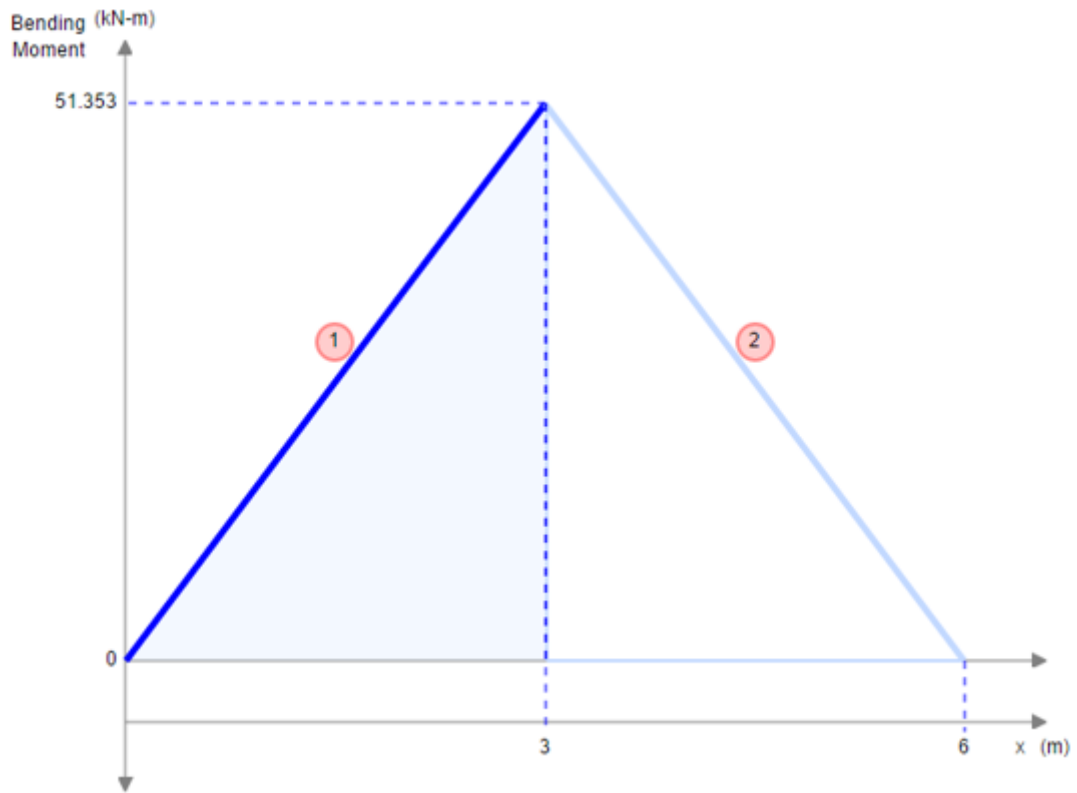

Figure 13 Bending moment

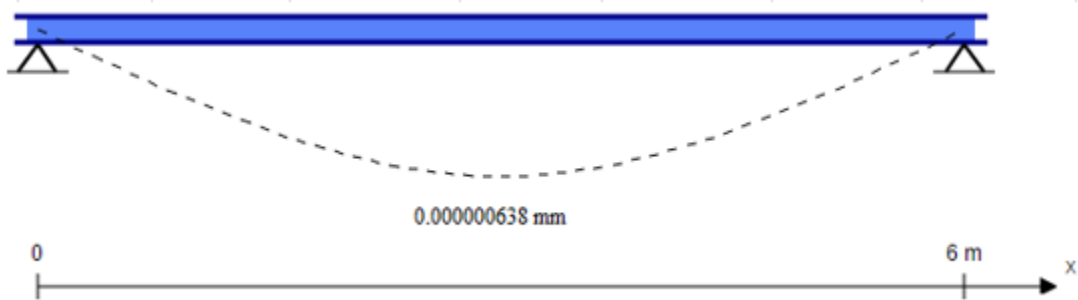

Figure 14 Deflection

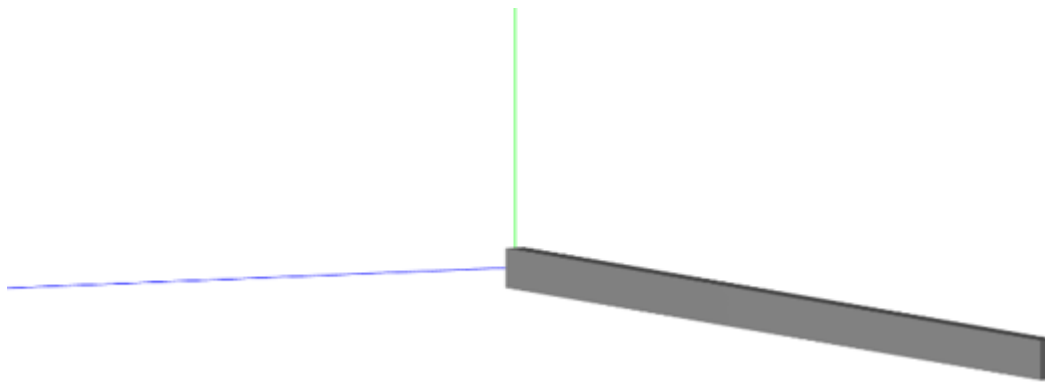

Figure 15 (3D) renderer and colored results

Area of Steel							
$La = 0.9 \times H$		H		$Total$			
$La =$	0.9	\times	8	$=$	7.2	in	
	$A_s = \frac{Mu}{0.9 \times fy \times la}$				$Mu =$	51.352722	$kN/m \rightarrow \approx 93.33464558$
$A_s =$	$\frac{93.33464558}{0.9 \times 60 \times 7.2}$			\rightarrow	$Total$		
					0.240058245		
$A_s \text{ min} =$	$\frac{200}{Fy}$				$Total$		
	200	\div	60000	$=$	0.0033		
$A_s \text{ max} =$	$0.75 \times A_{sb}$						
	$A_{sb} = N_{cb} / Fy$						
	$N_{cb} = 0.85 \times f_c \times a_s \times b$						
	$\frac{Cb}{0.003} = \frac{La - Cb}{0.00207}$						
	from the formula above we get $Cb = 5.4$ in						
$a = \beta \times Cb$	$\rightarrow \beta = 0.85$ for $f_c \leq 4000$ psi						
$a =$	0.85	\times	5.4	$=$	4.59	in	
$b =$	1	ft	\rightarrow	12	in	(assuming)	
$N_{cb} =$	0.85	\times	4000	\times	4.59	\times	$12 = 187272$
							$Ib/in^2 \rightarrow 187.272$
$A_{sb} =$	187.272	\times	60	$=$	3.1212	in^2	
$A_s \text{ max} =$	0.75	\times	3.1212	$=$	2.3409	in^2	
we will use A_s as the area of steel bars = 0.240058245 in ²							

Use the table to Find the Number of Bars and Diameter of bars

Table 2.10 Areas of Multiple of Reinforcing Bars (in²)

Number of bars	Bar number								
	#3	#4	#5	#6	#7	#8	#9	#10	#11
1	0.11	0.20	0.31	0.44	0.60	0.79	1.00	1.27	1.56
2	0.22	0.40	0.62	0.88	1.20	1.58	2.00	2.54	3.12
3	0.33	0.60	0.93	1.32	1.80	2.37	3.00	3.81	4.68
4	0.44	0.80	1.24	1.76	2.40	3.16	4.00	5.08	6.24
5	0.55	1.00	1.55	2.20	3.00	3.95	5.00	6.35	7.80
6	0.66	1.20	1.86	2.64	3.60	4.74	6.00	7.62	9.36
7	0.77	1.40	2.17	3.08	4.20	5.53	7.00	8.89	10.92
8	0.88	1.60	2.48	3.52	4.80	6.32	8.00	10.16	12.48
9	0.99	1.80	2.79	3.96	5.40	7.11	9.00	11.43	14.04
10	1.10	2.00	3.10	4.40	6.00	7.90	10.00	12.70	15.60

Take 1#5 Ø

→

1 No. 5 bars

Shear					
$V_v = R - W_{ub} * (h')$					
$h' = 2 * b$					
$V_v =$	17.199	-	0.054	*(6 m - 5.8 m) =	17.188 kN
$V_v = \phi V_c + V_s$					
$V_c = 2 \phi \sqrt{f'_c} b w d$					
$V_c = 2$	*	0.85	*	$\sqrt{4351.131}$	* 4 * 8 = 3588.3928 psi
3588.3928 lb	→	1628.127414 kg	→	15955.64866 N	→ 15.9556 kN
V_s	→	$\frac{17.188 - 15.9556}{0.85}$	=	1.449889578	kN
from V_s calculate stirrups :					
$V_s = \frac{A_v * f_y * d}{S}$					
$S =$	0.220	5.4	7.20	=	5.899 in
according to ACI the spacing of shear reinforcement should not be longer of the smaller of the following :					
①	$d/2$	8 in	× 2	=	4 in → = 102mm
②	$\frac{A_v f_y}{50 b w}$	0.220	× 60	=	0.033 in
		50	× 8 in		

Deflection for Sub-beam Roof												
$\Delta_{max} = \frac{5 \cdot \omega \cdot L^4}{384 \cdot E \cdot I_x} + \frac{P \cdot L^3}{48 \cdot E \cdot I_x}$		5	×	0.000054216	×	1.296E+15	+	0.0486105	×	2.16E+11		
		384	×	25,000	×	71050704.3		48	×	25,000	×	71050704.3
		$\Delta_{max} =$		0.000515066	+	0.00012315						
		$\Delta_{max} =$		0.000638216	mm	→		6.38216E-07		m		
$\Delta_{actual} = \frac{L}{240}$		6						Prefixes				
		240						E=	25,000	kN/m		
								I_x sub-beam=	71050704.3	mm ⁴		
								I_x girder=	14047810614	mm ⁴		
$\Delta_{actual} =$	0.025	mm	→	=	0.000025	m						
$\Delta_{actual} > \Delta_{max}$	0.025	>		6.38216E-07	m							

2.3.5 Calculations of loads for beam:

critical beam						
Loading						
Loading on Floor =		Wu × Spacing =			Total	
		16.2035	kN/m ²	×	6 m	= 97.221 kN/m

2.3.6 Design of the beam:

Beam Weight						
Length =	L	12 m	472.32 in			
1- Find Depth of Beam (h) =	L/16 =	29.52 in	≈ 30 in	=	762 mm	
2- Find Width of Beam (b) =	h/2 =	14.76 in	≈ 15 in	=	381 mm	
3- Self weight of Beam (Bw) =	b × h × Density =	30 in	15 in	150 lb/ft ³		
		→	2.500 ft	×	1.250 ft	× 150 lb/ft ³ = 468.75 lb/ft
convert	468.75 lb/ft	→ ≈	0.6355 kN/m			
W _{ub} =	0.6355	1.2	0.7626 kN/m			
point load from reaction acting on sub beam of floor R =					24.467898 kN	
P1=	24.467898 × 2	=	48.935796 kN			
P2=	24.467898 × 2	=	48.935796 kN			
P3=	24.467898 × 2	=	48.935796 kN			
					h = 762 mm	
4- reaction force acting on beam:						
R ₁ , R ₂ →	$\frac{3P}{2} + \frac{WL}{2}$					b = 381 mm
R1 →	$\frac{3}{2} \times 48.9358 + \frac{0.7626}{2} \times 12 \text{ m}$			→ =	77.979294 kN	
R2 →	$\frac{3}{2} \times 48.9358 + \frac{0.7626}{2} \times 12 \text{ m}$			→ =	77.979294 kN	
5- moment:						
$\frac{WL^2}{8} + \frac{PL}{4} + Pa$	→	$\frac{0.7626}{8} \times 144 \text{ m} + \frac{48.9358}{4} \times 12 \text{ m}$			+ 48.9358 × 3	
M =	→	307.34158 kN/m				
Moment formula from steel book from moments table 3-23						

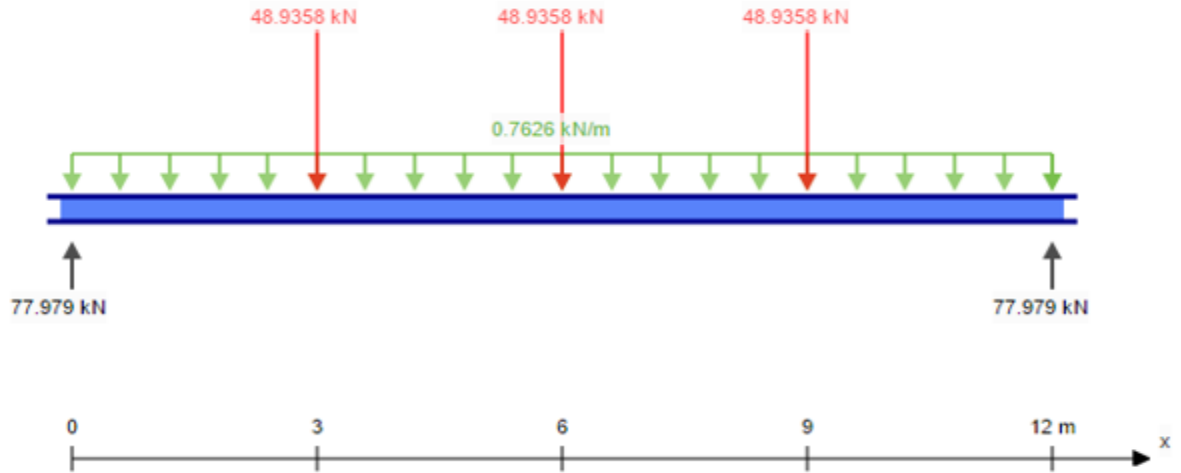

Figure 16 Force acting on sub-beam & reaction force

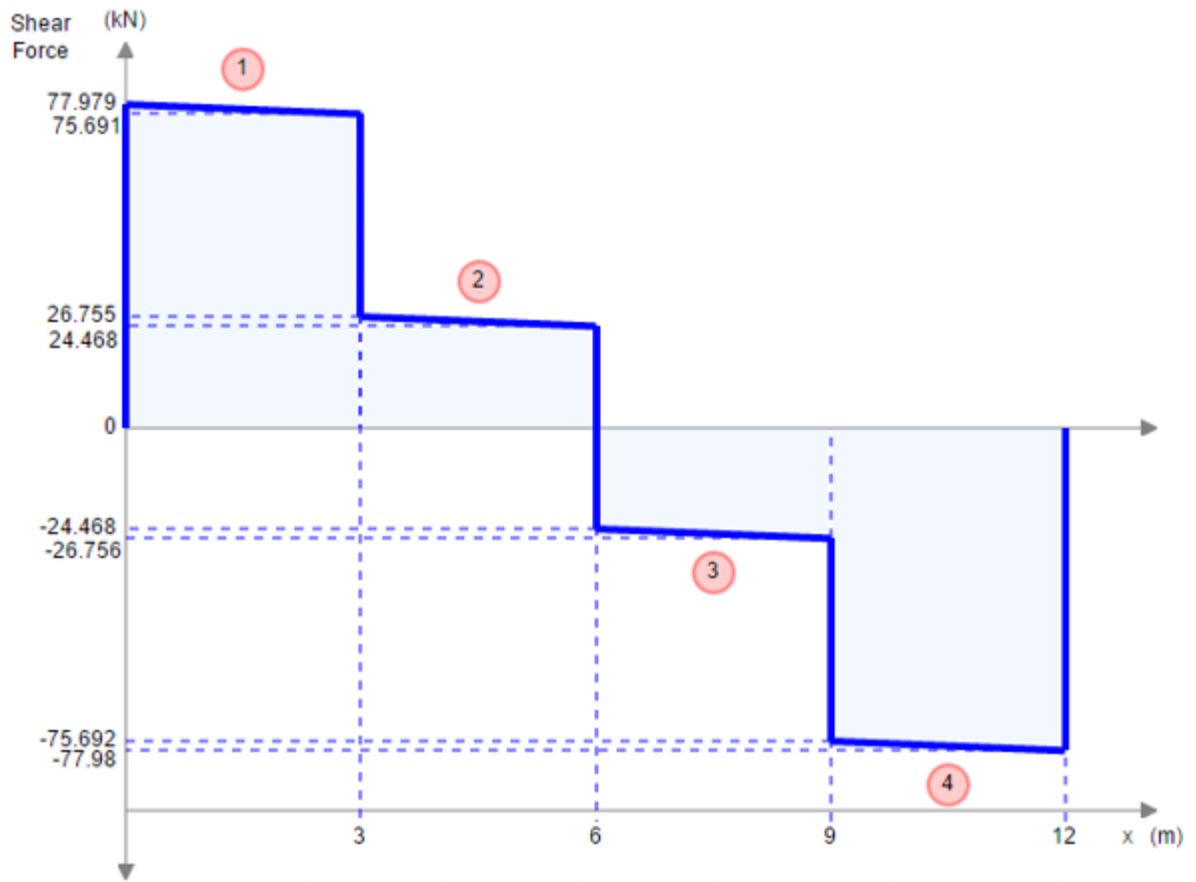

Figure 17 Shear force

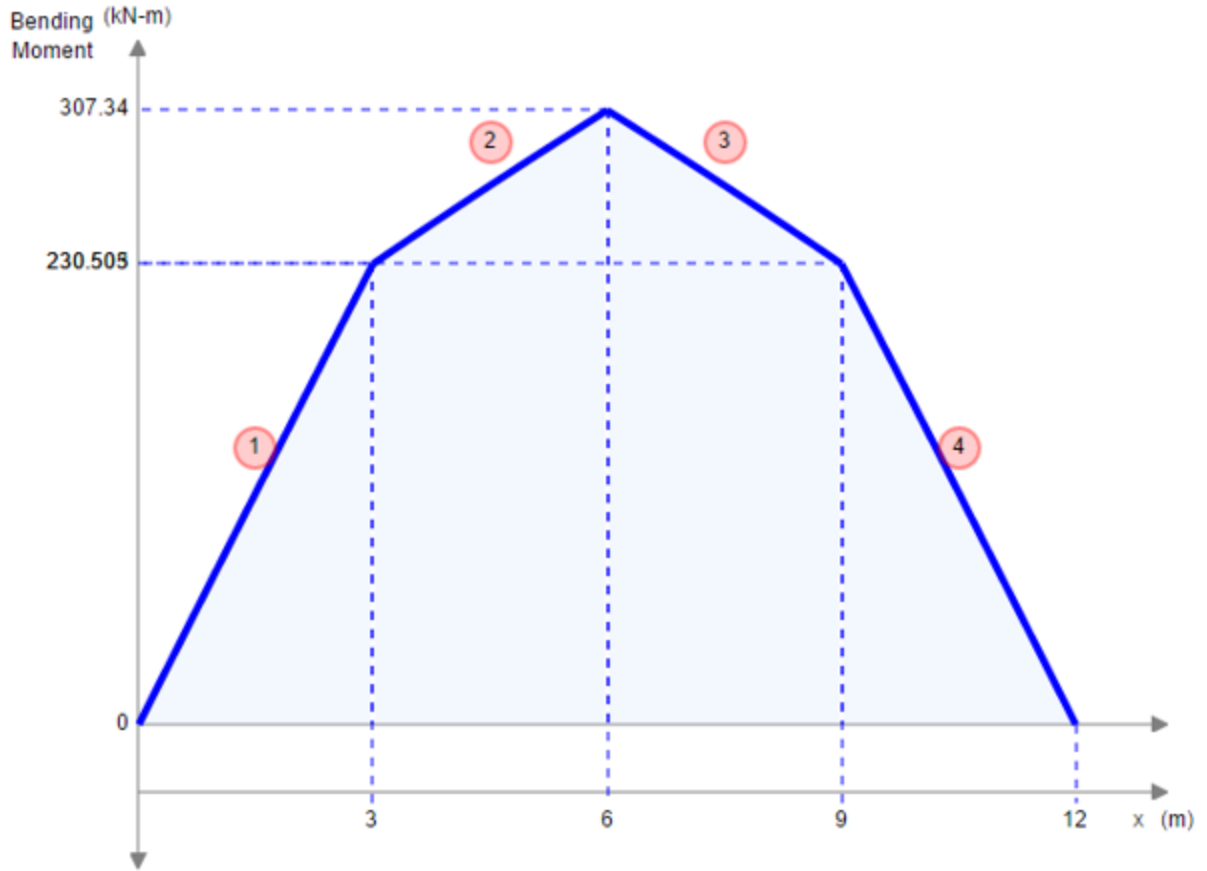

Figure 18 Bending moment

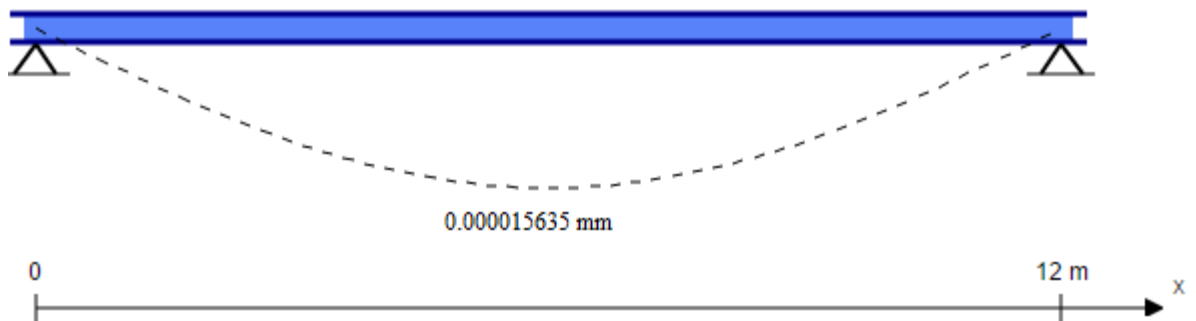

Figure 19 Deflection

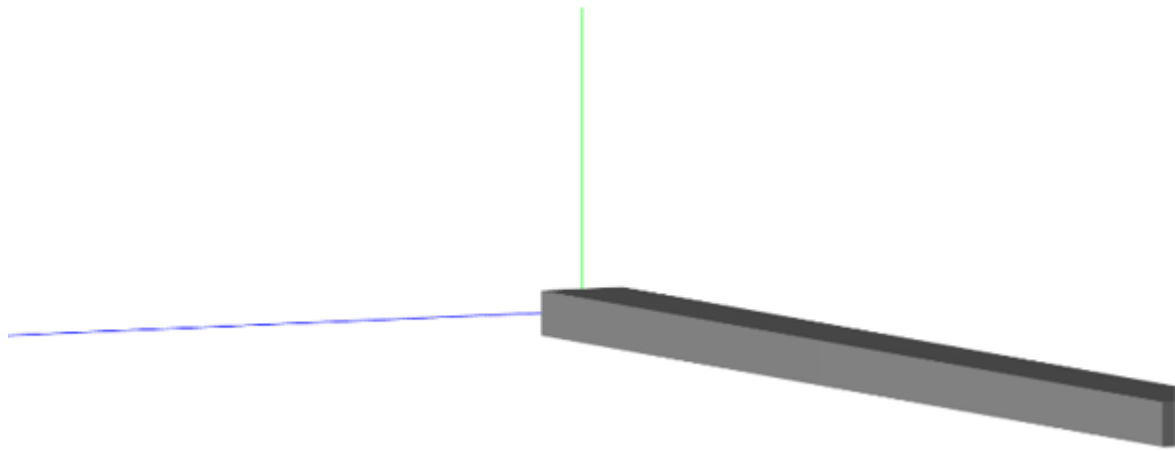

Figure 20 (3D) renderer and colored results

Area of Steel									
$La = 0.9 \times H$		H		Total					
La=	0.9	×	30 in	=	27 in				
$A_s = \frac{Mu}{0.9 \cdot f_y \cdot la}$					Mu =	307.341576 kN/m	→	≈	558.5997383 kip-in
$A_s =$	558.5997		→		Total				
	0.9	×	60	×	27	0.383127393 in ²			
$A_s \text{ min} =$	200/Fy		Total						
	200	÷	60000	=	0.0033 in ²				
$A_s \text{ max} =$	0.75 x A_{sb}								
	$A_{sb} = N_{cb}/F_y$								
	$N_{cb} = 0.85 \cdot f_c \cdot a_b \cdot b$								
	$\frac{Cb}{0.003} = \frac{La - Cb}{0.00207}$								
from the formula above we get Cb= 5.4 in									
$a = \beta \cdot Cb$	→ $\beta = 0.85$ for $f_c \leq 4000$ psi								
a=	0.85	×	5.4	=	4.59	in			
b =	1 ft	→		12 in	(assuming)				
$N_{cb} =$	0.85	×	4000	×	4.59	×	12	=	187272 Ib/in ² → 187.272 KIb
$A_{sb} =$	187.272	×	60	=	3.1212	in ²			
$A_s \text{ max} =$	0.75	×	3.1212	=	2.3409	in ²			
we will use A_s as the area of steel bar 0.3831274 in ²									

Use the table to Find the Number of Bars and Diameter of bars

Table 2.11 Areas of Multiple of Reinforcing Bars (in²)

Number of bars	Bar number								
	#3	#4	#5	#6	#7	#8	#9	#10	#11
1	0.11	0.20	0.31	0.44	0.60	0.79	1.00	1.27	1.56
2	0.22	0.40	0.62	0.88	1.20	1.58	2.00	2.54	3.12
3	0.33	0.60	0.93	1.32	1.80	2.37	3.00	3.81	4.68
4	0.44	0.80	1.24	1.76	2.40	3.16	4.00	5.08	6.24
5	0.55	1.00	1.55	2.20	3.00	3.95	5.00	6.35	7.80
6	0.66	1.20	1.86	2.64	3.60	4.74	6.00	7.62	9.36
7	0.77	1.40	2.17	3.08	4.20	5.53	7.00	8.89	10.92
8	0.88	1.60	2.48	3.52	4.80	6.32	8.00	10.16	12.48
9	0.99	1.80	2.79	3.96	5.40	7.11	9.00	11.43	14.04
10	1.10	2.00	3.10	4.40	6.00	7.90	10.00	12.70	15.60

Take 2#4 Ø

→

2 No. 4 bars

Find the actual La

						Prefixes	
Actual d = h - Cover - stirrup - $\frac{d_b}{2}$						h	= 8 in
La = 0.9 x H						cover	= 1.50 in
La = 0.9 x 30 in = 27 in						d _b	= 1
						1	
Actual d = 30 - 1.50 - $\frac{0.0088}{2}$ =							28 in
						2	

Shear																	
$V_v = R - W_{ub} * (h')$																	
$h' = 2 * b$																	
$V_v = 77.979 - 0.763 * (6 \text{ m} - 5.8 \text{ m}) = 77.827 \text{ kN}$																	
$V_v = \phi V_c + V_s$																	
$V_c = 2 \phi \sqrt{f'_c} b w d$																	
$V_c = 2 * 0.85 * \sqrt{4351.131} * 30 * 15 = 50461.7740 \text{ lb}$																	
$50461.7740 \text{ lb} \rightarrow 22895.54 \text{ kg} \rightarrow 224376.31 \text{ N} \rightarrow 224.3763 \text{ kN}$																	
$V_s \rightarrow \frac{224.3763 - 77.827}{0.850} = 172.41122 \text{ kN}$																	
from V_s calculate stirrups :																	
$V_s = \frac{A_v * f_y * d}{S}$																	
$S = \frac{0.220 * 4000 * 27.00}{172.411218} = 137.810 \text{ in}$																	
according to ACI the spacing of shear reinforcement should not be longer of the smaller of the following :																	
<table border="0"> <tr> <td style="text-align: center;">❶</td> <td style="text-align: center;">$d/2$</td> <td style="text-align: center;">$30 \text{ in} \times 2$</td> <td style="text-align: center;">$= 15 \text{ in}$</td> <td style="text-align: center;">$\rightarrow =$</td> <td style="text-align: center;">381 mm</td> </tr> <tr> <td style="text-align: center;">❷</td> <td style="text-align: center;">$\frac{A_v f_y}{50 b w}$</td> <td style="text-align: center;">$\frac{0.220 \times 60}{50 \times 30 \text{ in}}$</td> <td style="text-align: center;">$= 0.0088 \text{ in}$</td> <td></td> <td></td> </tr> </table>						❶	$d/2$	$30 \text{ in} \times 2$	$= 15 \text{ in}$	$\rightarrow =$	381 mm	❷	$\frac{A_v f_y}{50 b w}$	$\frac{0.220 \times 60}{50 \times 30 \text{ in}}$	$= 0.0088 \text{ in}$		
❶	$d/2$	$30 \text{ in} \times 2$	$= 15 \text{ in}$	$\rightarrow =$	381 mm												
❷	$\frac{A_v f_y}{50 b w}$	$\frac{0.220 \times 60}{50 \times 30 \text{ in}}$	$= 0.0088 \text{ in}$														

Deflection for Girder																	
$\Delta_{max} = \frac{5 \omega * L^4}{384 * E * I_x} + \frac{P * L^3}{48 * E * I_x}$																	
$\frac{5 \times 0.0007626 \times 2.0736 \text{E}+16}{384 \times 25000 \times 14047810614} + \frac{48.935796 \times 1.728 \text{E}+12}{48 \times 25000 \times 14047810614}$																	
$\Delta_{max} = 0.0005863 + 0.015048796$																	
$\Delta_{max} = 0.0156351 \text{ mm} \rightarrow 1.56351 \text{E}-05 \text{ m}$																	
$\Delta_{actual} = \frac{L}{240}$																	
$\frac{12 \text{ m}}{240}$																	
$\Delta_{actual} = 0.05 \text{ mm} \rightarrow = 0.00005 \text{ m}$																	
$\Delta_{actual} > \Delta_{max} \quad 0.05 > 1.564 \text{E}-05 \text{ m}$																	
<table border="1"> <thead> <tr> <th colspan="3">Prefixes</th> </tr> </thead> <tbody> <tr> <td>E=</td> <td>25,000</td> <td>kN/m</td> </tr> <tr> <td>I_x sub-beam=</td> <td>71050704.3</td> <td>mm⁴</td> </tr> <tr> <td>I_x girder=</td> <td>14047810614</td> <td>mm⁴</td> </tr> </tbody> </table>						Prefixes			E=	25,000	kN/m	I_x sub-beam=	71050704.3	mm ⁴	I_x girder=	14047810614	mm ⁴
Prefixes																	
E=	25,000	kN/m															
I_x sub-beam=	71050704.3	mm ⁴															
I_x girder=	14047810614	mm ⁴															

2.4 Design of columns

Columns are the third important element in structural system which are defined as members that carry load chiefly in compression .usually columns carry bending moment as well about one or both axis of the cross section

2.4.1 Classification of columns:

Column are generally classified according to:

a) The load acting on column:

- 1) Axially loaded column: where the load act at the center of the column Section
- 2) Eccentrically loaded columns: where the load is acting at distance e form the center of column cross section in any direction.
- 3) Biaxial loaded columns: where the loads are acting at any point on the columns section causing moment about axis of the section

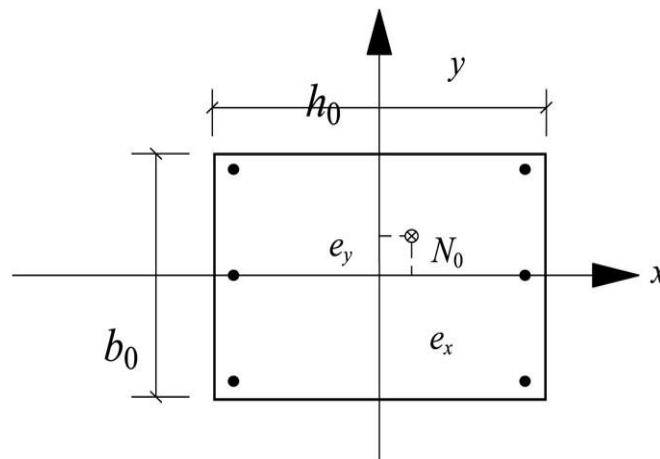

Figure 21 Cross section for eccentrically loaded column.

b) The column length:

- 1) Short columns: where the columns failure is due to the crushing of concrete or yielding of the steel bars under the capacity of the columns.
- 2) Long columns: Where the effect of the buckling and the slenderness ratio must be taken into consideration in the design.

c) The columns ties:

- 1) Members reinforced with longitudinal bars and lateral ties (Rectangular columns)
- 2) Members reinforced with longitudinal bars and continuous spiral (circular columns)

d) sample of calculations of rectangular columns:

- **Steps of design:**
 - 1) Check the type of the floor in each direction (sway or non-sway)
 - 2) Determine the load applied and the critical load combination
 - 3) Check if the column is slender or not.
- **If columns is slender finds its magnified moment, then compare this with the calculated minimum moment:**
 - 4) Then find out the required area of steel
 - 5) Calculate the ties or stirrup reinforcement
 - 6) Draw the detailing of the columns

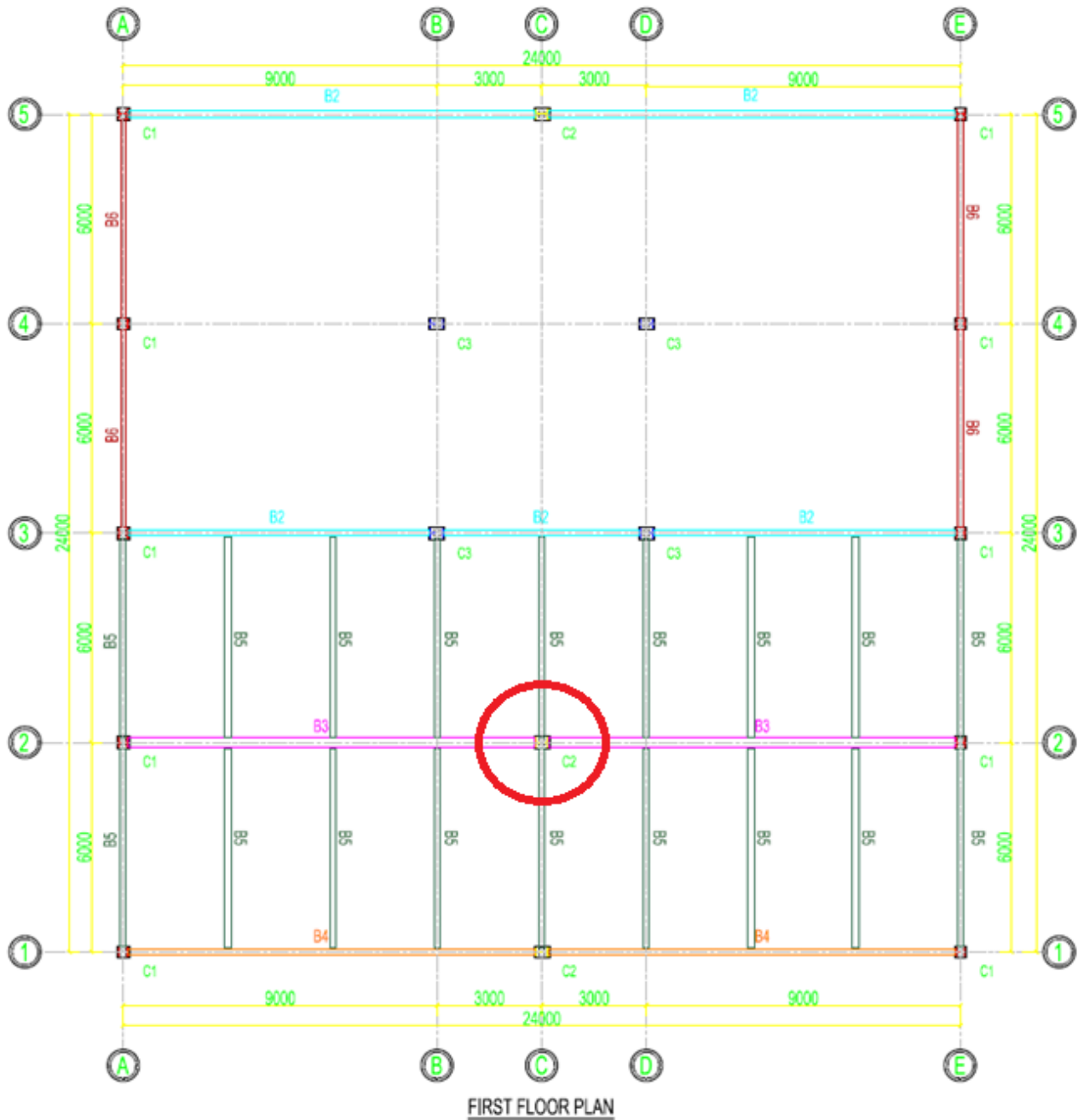

Figure 22 Column selected for the sample of calculation is 2C Shown in the Figure

2.4.3 Materials properties:

Table 5 Properties

concrete	f_c'	30 MPa
steel	F_y	420 MPa

2.4.4 Load Calculation:

General formula for P_u of column				
$P_u = 0.8 \phi * 0.85 f_c A_g$				
→ for rectangular beam $\phi = 0.7$				
For Column # 2C in Drawing : ↓				
1- ROOF :				
loads acting on column are 1/4 of 4 slabs				
$W_u =$	11.3575	kN/m^2		
for 1/4 of 4 slabs → =	$18 m^2$	→	18×11.3575	= 204.435 kN
$P_{girder} =$	0.7626×9	=	$6.8634 kN$	
$P_u =$	204.435×6.8634	=	$211.2984 kN$	
2- FLOOR:				
loads acting on column are 1/4 of 4 slabs				
$W_u =$	16.2035	kN/m^2		
for 1/4 of 4 slabs →	$18 m^2$	→	18×16.2035	= 291.663 kN
$P_{girder} =$	0.7626×9	=	$6.8634 kN$	
$P_u =$	$291.663 + 6.8634$	=	$298.5264 kN$	
ROOF + FLOOR		→	$211.2984 + 298.5264$	= 509.8248 kN
convert:	509.8248	$kN \rightarrow$	114.6131744	kips
$114.6131744 =$	$0.8 \times 0.7 \times 0.85 \times 6 \times A_g$			
$A_g =$	$40.13066331 in^2$	→ =	$25890.69874 mm^2$	

Column Weight						
Length =	12 m	→	472.44 in			
1- Find Depth of column (h) =	L/16 =	29.53 in	≈ 30 in	=	762 mm	
2- Find Width of column (b) =	h/2 =	14.76 in	≈ 15 in	=	381 mm	
3- Self weight of column (Bw) =	b × h × Density =	30 in	15 in	150 lb/ft ³		
		→	2.500 ft × 1.250 ft	× 150 lb/ft ³	468.75 lb/ft	
convert	468.75 lb/ft → ≈	0.04518 kN/m				
Wub =	0.04518 × 1.2 =	0.054216 kN/m				
4- reaction force acting on column =			h = 762 mm			
R =	281.1951 kN					
5- moment:						
M =	712.766 kN/m				b = 381 mm	

Area of Steel						
A _g =	40.13066331 in ²					
to find A _s →	$\rho = \frac{A_s}{bh}$	→	$\rho =$	between	0.01	& 0.08
				assuming that $\rho =$	0.01	
0.01 =	$\frac{A_s}{15 \text{ in} \times 30 \text{ in}}$		A _s → =	4.5 in ²		
A _s min =	$\frac{200}{F_y}$		Total			
	200 ÷ 60000 =		0.0033 in ²			
La = 0.9 x H		H	Total			
La =	0.9 × 30 in =		27 in			
we will use A _s as the area of steel bars =			4.5 in ²			

Use the table to Find the Number of Bars and Diameter of bars

Table 2.13 Areas of Multiple of Reinforcing Bars (in²)

Number of bars	Bar number								
	#3	#4	#5	#6	#7	#8	#9	#10	#11
1	0.11	0.20	0.31	0.44	0.60	0.79	1.00	1.27	1.56
2	0.22	0.40	0.62	0.88	1.20	1.58	2.00	2.54	3.12
3	0.33	0.60	0.93	1.32	1.80	2.37	3.00	3.81	4.68
4	0.44	0.80	1.24	1.76	2.40	3.16	4.00	5.08	6.24
5	0.55	1.00	1.55	2.20	3.00	3.95	5.00	6.35	7.80
6	0.66	1.20	1.86	2.64	3.60	4.74	6.00	7.62	9.36
7	0.77	1.40	2.17	3.08	4.20	5.53	7.00	8.89	10.92
8	0.88	1.60	2.48	3.52	4.80	6.32	8.00	10.16	12.48
9	0.99	1.80	2.79	3.96	5.40	7.11	9.00	11.43	14.04
10	1.10	2.00	3.10	4.40	6.00	7.90	10.00	12.70	15.60

Take 3 # 11 Ø

→

3 No. 11 bars

Shear

$$V_v = R - W_{ub} * (h')$$

$$h' = 2 * b$$

$$V_v = 281.195 - 0.054 * (6 \text{ m} - 5.8 \text{ m}) = 281.184 \text{ kN}$$

$$V_v = \phi V_c + V_s$$

$$V_c = 2 \phi \sqrt{f'c} b w d$$

$$V_c = 2 * 0.85 * \sqrt{4351.131} * 30 * 15 = 50461.7740 \text{ lb}$$

$$50461.7740 \text{ lb} \rightarrow = 22895.54176 \text{ kg} \rightarrow = 224376.3093 \text{ N} \rightarrow = 224.3763 \text{ kN}$$

$$V_s \rightarrow \frac{281.1843 \times 224.376}{0.850} = 66.83287946 \text{ kN}$$

from V_s calculate stirrups :

$$V_s = \frac{A_v * f_y * d}{S}$$

$$S = \frac{0.220 \times 60 \times 27.00}{66.83287946} = 5.333 \text{ in}$$

according to ACI the spacing of shear reinforcement should not be longer of the smaller of the following :

①	$d/2$	30 in	× 2	= 15 in → = 381 mm
②	$\frac{A_v f_y}{50 b w}$	0.220	× 60	= 0.0088 in
		50	× 30 in	

2.5 Design of dome

2.5.1 Classification of dome:

A dome is an architectural element that resembles the hollow upper half of a sphere. The precise definition has been a matter of controversy. There are also a wide variety of forms and specialized terms to describe them. A dome can rest upon a rotunda or drum, and can be supported by columns or piers that transition to the dome through squinches or pendentives. A lantern may cover an oculus and may itself have another dome.

Domes have a long architectural lineage that extends back into prehistory and they have been constructed from mud, stone, wood, brick, concrete, metal, glass, and plastic over the centuries. The symbolism associated with domes includes mortuary, celestial, and governmental traditions that have likewise developed over time.

Domes have been found from early Mesopotamia, which may explain the form's spread. They are found in Persian, Hellenistic, Roman, and Chinese architecture in the Ancient world, as well as among a number of contemporary indigenous building traditions. They were popular in Byzantine and medieval Islamic architecture, and there are numerous examples from Western Europe in the middle Ages. The Renaissance style spread from Italy in the early modern period. Advancements in mathematics, materials, and production techniques since that time resulted in new dome types. The domes of the modern world can be found over religious buildings, legislative chambers, sports stadiums, and a variety of functional structures.

Domes in Islamic architecture:

When he built the Messenger of Allah bless him and his mosque in Medina, was the roof of the mobile fronds on the palm trunks, the case remained on it among the mosques was not the dome has entered the building of mosques.

The first dome was built in Islam are Dome of the Rock mosque in Jerusalem built by the Umayyad Caliph Abdul Malik bin Marwan year 72 AH. Muslims and was able to be transferred to the customs of the Maghreb and Al-Andalus, and today we find a beautiful example of the city and the valley will (State of the valley) in the east of Algeria domes that make up the foundation element in roofing Hjratha. And people still call in the Orient and some of Morocco on the room or the Dome of the room

2.5.2 Calculations of dome:

Dome			
Given Data of Concrete Dome:			
$H_1 =$	3.8	m	
$H_2 =$	4	m	
$R_1 =$	2.8	m	
$R_2 =$	3	m	
$Th =$	0.2	m	
			Prefixes
			$\Pi = 3.14$
$V_1 = \pi / 6 * h_1 (3 R_1^2 + H_1^2)$			
$V_1 =$	75.48979	m^3	
$V_2 = \pi / 6 * h_2 (3 R_2^2 + H_2^2)$			
$V_2 =$	85.51267	m^3	
Total V =	$V_2 - V_1$		
	$85.51267 - 75.48979 = 10.02288 m^3$		
D= kN/m^3	V= m^3	Total	
24.525	\times 10.02288	= 245.8111 kN	
1/4 OF DOME			
$245.811132 \div 4 = 61.45278 kN$			

- Sap2000 design:

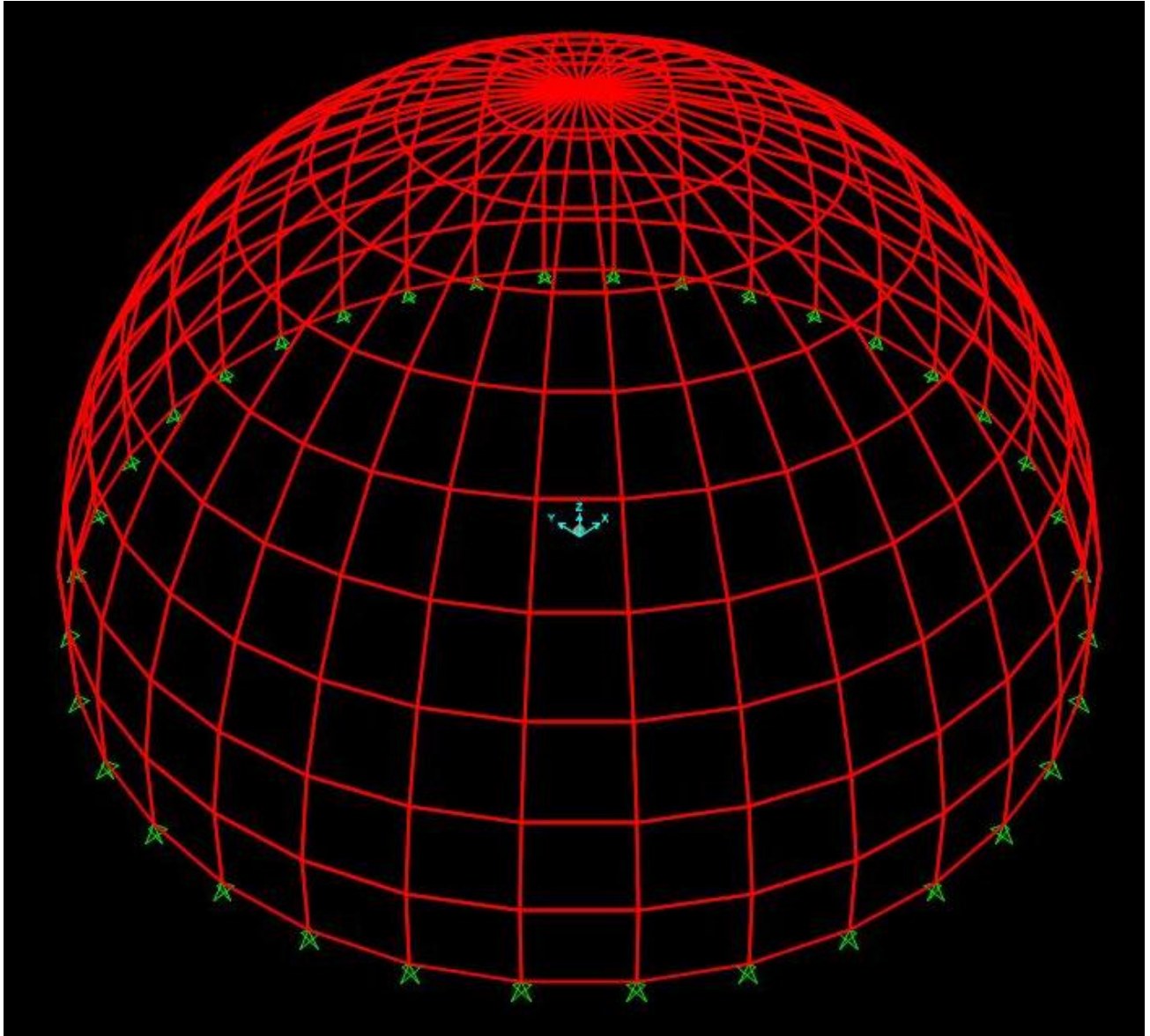

Figure 23 (3D) Dome structural design.

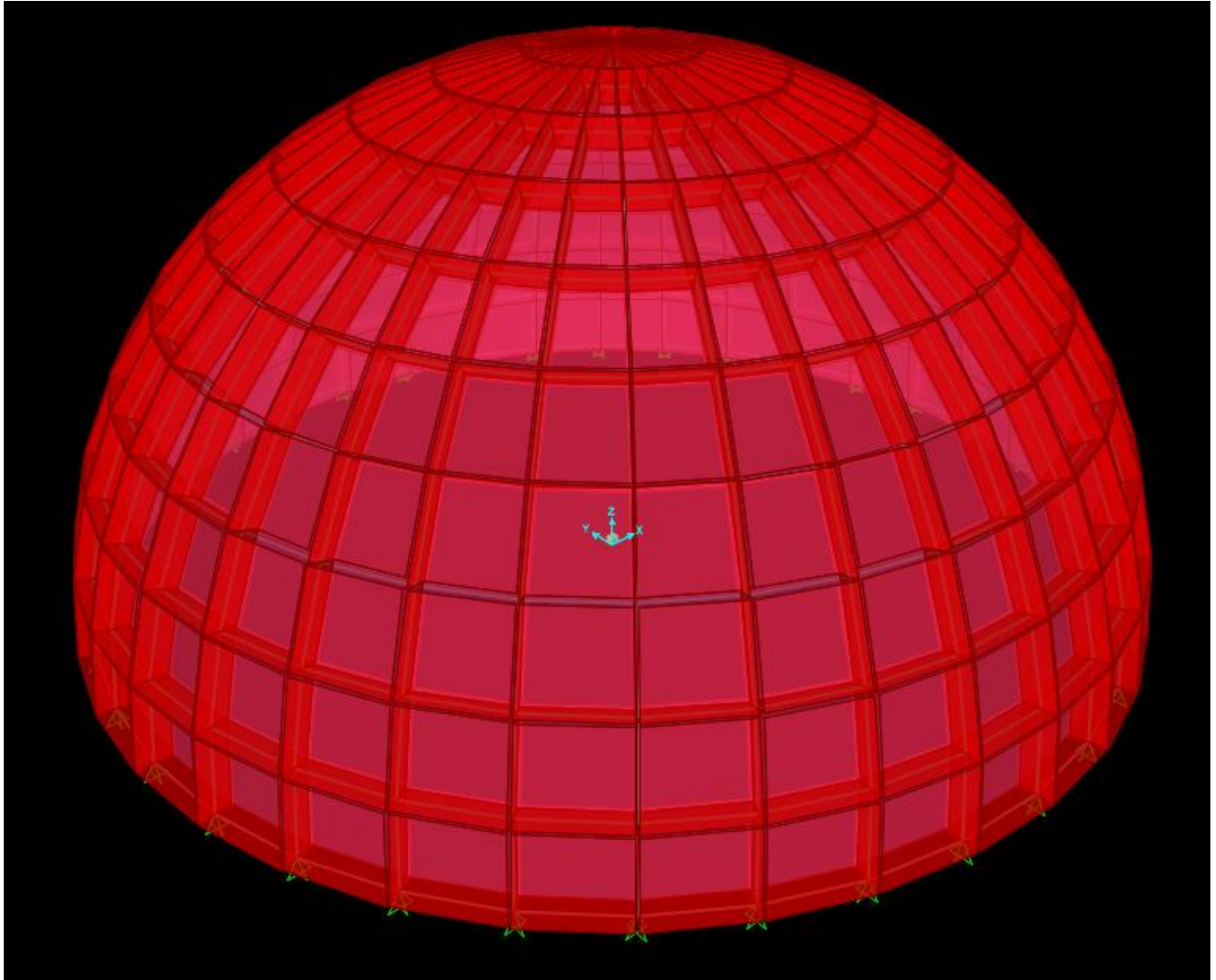

Figure 24 (3D) dome overview design.

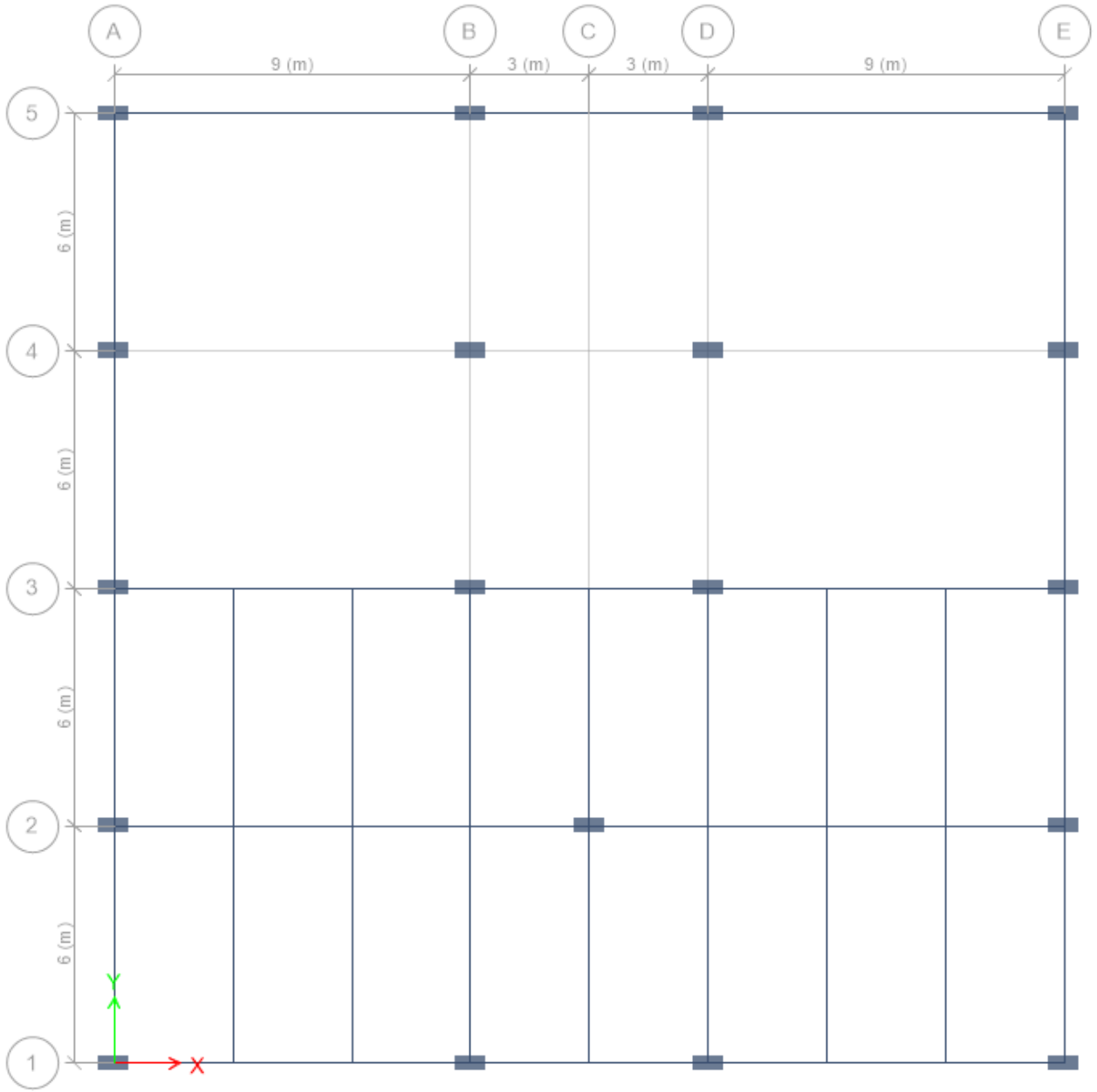

Figure 25 Top view for 1st floor (mezzanine)

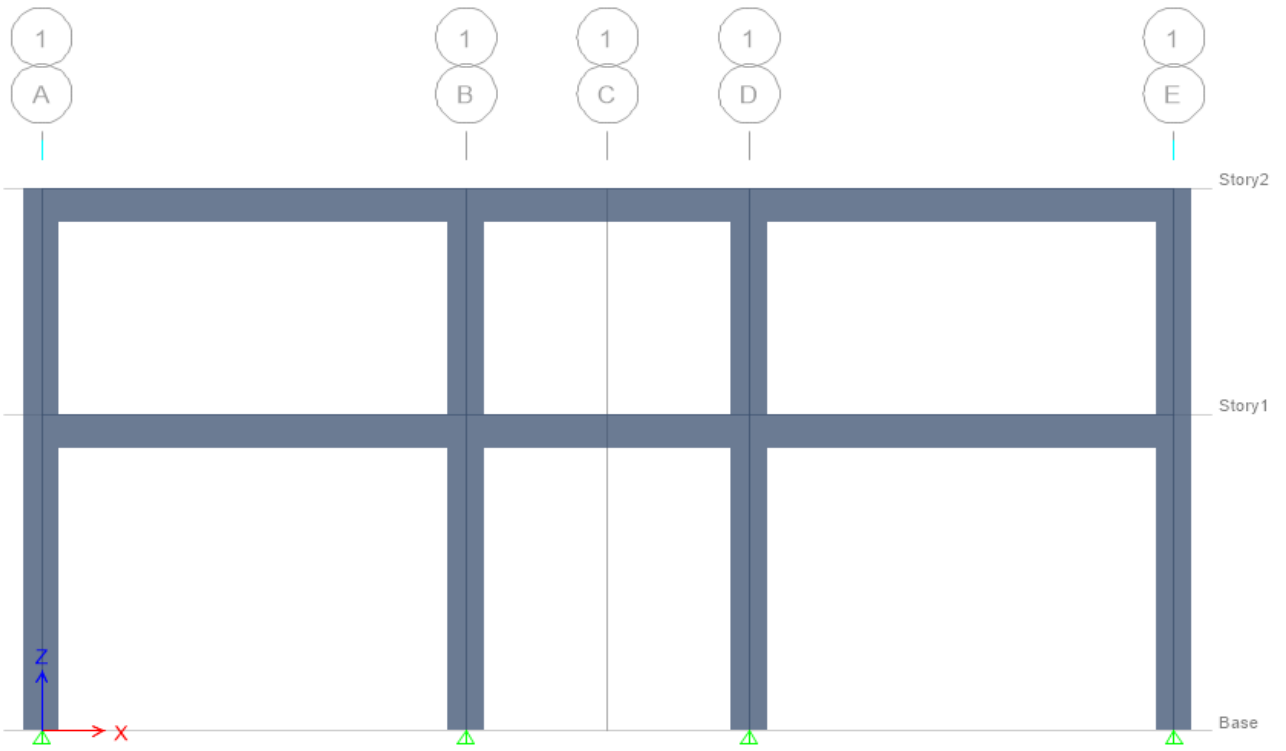

Figure 26 Side view for 1st floor (mezzanine)

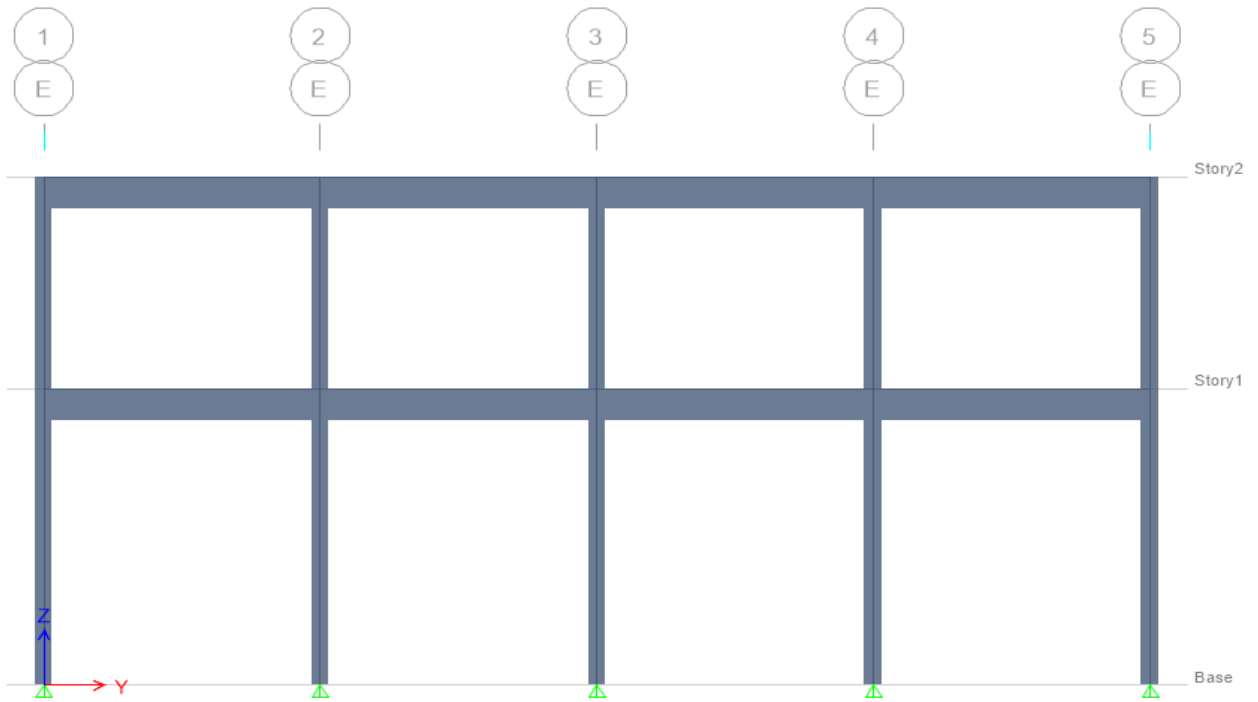

Figure 27 Side view

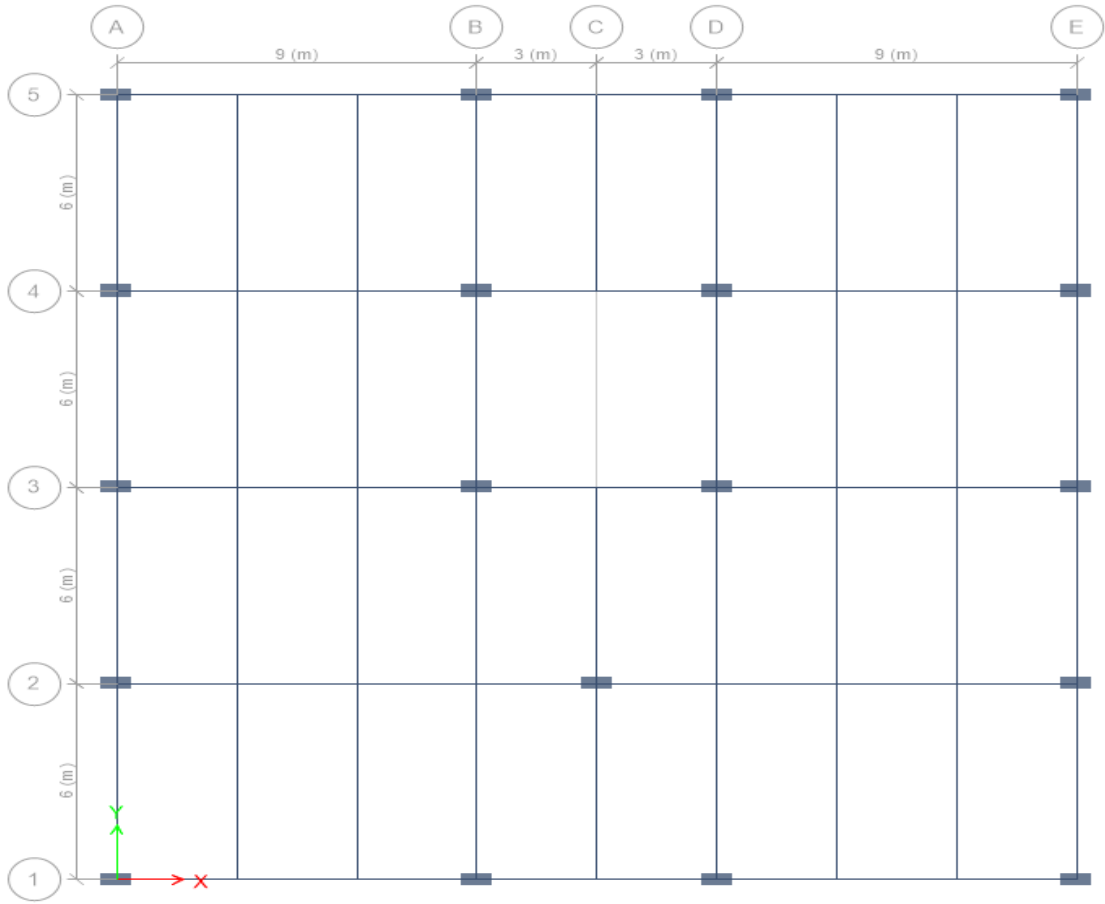

Figure 28 Top view for Roof

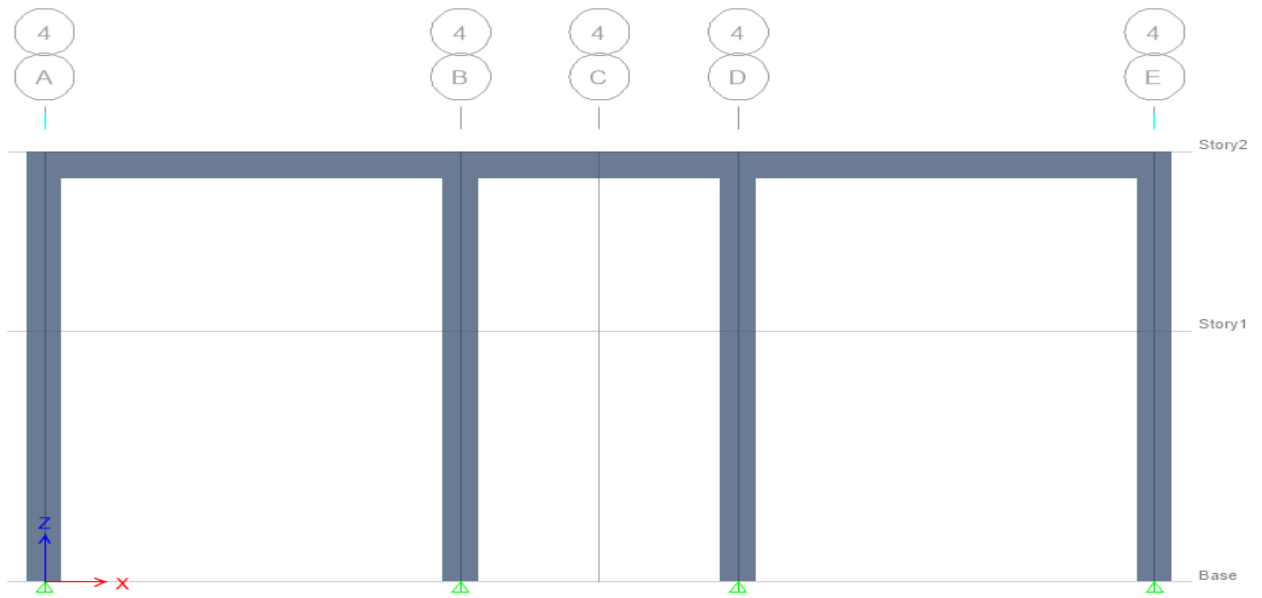

Figure 29 Front view

Chapter 3: Steel

Symbols:

<u>SHORTS</u>	<u>MEANING</u>
A_g	Gross Area of Section
A_w	Web Area
C_b	Lateral Torsional buckling
C_v	Web Shear
C_w	Warping Constant
E	Modulus of Elasticity
F_{cr}	Buckling Stress
F_e	Elastic Critical Buckling Stress
F_y	Yielding Stress
I_x	Moment of inertia at X- axis
I_y	Moment of inertia at Y- axis
J	Torsional Constant
K	Effective Length
K_v	Plate Buckling Coefficient
L	Length
L_b	Distance between Braces
L_p, L_r	Limiting Laterally Unbrace Length
M_{max}	Maximum Moment
M_n	Nominal Flexure Strength
M_p	Plastic Bending Moment
M_u	Ultimate Moment

P_n	Nominal Axial Strength
S_x	Elastic modulus at X-axis
S_y	Elastic modulus at Y-axis
V_n	Nominal Shear Strength
V_u	Ultimate Shear Strength
Z_x	Plastic modulus at X-axis
Z_y	Plastic modulus at Y-axis
b	Width
C	Coefficient
d	Depth of Web
h	Overall height
h_o	Distance between Flange Centroid
r_x	Governing radius at X-axis
r_y	Governing radius at Y-axis
t_w	Thickness of Web
t_f	Thickness of Flange
ϕ_b	Resistance Factor for Flexure
ϕ_c	Resistance Factor for Compression
ϕ_v	Resistance Factor for Shear
Δ_{max}	Maximum Deflection
Δ_{act}	Actual Deflection

3.1 Introduction:

Steel buildings first gained popularity in the early 20th century. Their use became more widespread during World War II and significantly expanded after the war when steel became more available. Steel buildings have been widely accepted, in part due to cost efficiency. The range of application has expanded with improved materials, products and design capabilities with the availability of computer aided design software.

Steel provides several advantages over other building materials, such as wood:

- Steel is a "green" product; it is structurally sound and manufactured to strict specifications and tolerances. It is also energy efficient. Any excess material is 100% recyclable.
- Steel does not easily warp, buckle, twist or bend, and is therefore easy to modify and offers design flexibility. Steel is also easy to install.
- Steel is cost effective and rarely fluctuates in price.
- Steel allows for improved quality of construction and less maintenance, while offering improved safety and resistance.
- With the propagation of mold and mildew in residential buildings, using steel minimizes these infestations. Mold needs moist, porous material to grow. Steel studs do not have those problems.

This chapter will include three main sections: Design information, Structural analysis, and Design process.

3.2 Design Information:

This section will provide the applicable design codes, material specifications, and load combinations.

3.2.1 Applicable Design Codes:

The loads as described in the design summary sheet have been applied on the structure in accordance with:

- American Institute of Steel Construction (AISC) Manual of Steel Construction/ Load and Resistance Factor Design (LRFD).
- American Institute of Steel Construction (AISC) Manual of Steel Construction/ Allowable Strength Design (ASD).
- Saudi Building Code (SBC) For Minimum Design Loads for Buildings and Other Structures (301).
- European Specifications Beams (EURONORM) 53-62.
- Egyptian Building Code (EBS) For Connection design.

3.2.2 Material specifications:

The following is the list of the material standards and specifications for which the building components have been designed:

Table 6 Material specifications

No.	Materials	Specifications	Minimum Strength
1	Steel Members	ASTM A 992M Grade 345 Type 1	$F_y = 34.5 \text{ kN/cm}^2$ $F_u = 47.0 \text{ kN/cm}^2$
2	Bolts	ASTM A 36M Hot Dip Galvanized Class C	$F_y = 36.0 \text{ kN/cm}^2$ $F_u = 52.0 \text{ kN/cm}^2$
3	Plates	ASTM A 992M Grade 345 Type 1	$F_y = 34.5 \text{ kN/cm}^2$ $F_u = 47.0 \text{ kN/cm}^2$

3.2.3 Load Combinations:

This section will provide the calculation of the load combinations. These loads are calculated in accordance with Saudi Building Code (SBC) 301. These loads will be used in the structural analysis of the mezzanine beam and roof beam. Dome beam needs to calculate the dome weight and added to the load combination to do the structural analysis and dome beam design.

1- Dead Loads:

Table 7 Dead load

No.	Types of Dead load	Value	Note
1	Slab thickness	0.25 m	According to slab calculation in concrete section.
2	Beam weight	---	Steel section table.
3	Ceramic tiles	0.15 t/m	Saudi Building Code (SBC) – 301
4	Dome weight	20.52 t/m	According to dome calculation in concrete section.

Note: Slab is concrete-base. Density of Concrete 2.5 t/m^3

2- Live Loads:

Table 8 Live load

No.	Types of Live load	Value	Note
1	Mezzanine	0.5 t/m^2	Saudi Building Code (SBC) – 301
2	Roof	0.25 t/m^2	Saudi Building Code (SBC) – 301

Ultimate Load

Table 9 Ultimate load

No.	Types of Load	Factor of Safety	Note
1	Dead	1.2	Saudi Building Code (SBC) – 301
2	Live	1.6	Saudi Building Code (SBC) – 301

3.3 Structural Analysis:

As indicated previously, the mosque contains a ground floor and a mezzanine floor. The structural analysis will determine the critical reactions, maximum moment, and maximum shear.

Ultimate load that has been applied is taken according to the Saudi Building Code (SBC) as mentioned previously. The applied ultimate load is distributed load along the beam.

American Institute of Steel Construction (AISC) Manual of Steel Construction, Load and Resistance Factor Design (LRFD) will be applied on moment equations and shear equations. Moreover, SkyCiv software program will be used in addition to the calculations to determine the structural analysis.

In this section, a structural analysis will show the reactions on the mezzanine floor beam, the roof slab beam, dome beam, and column. Each beam will contain the input data and the output data. SkyCiv program will also show the moment diagram, shear diagram, and reaction forces. The results will be used during the design phase in the following section.

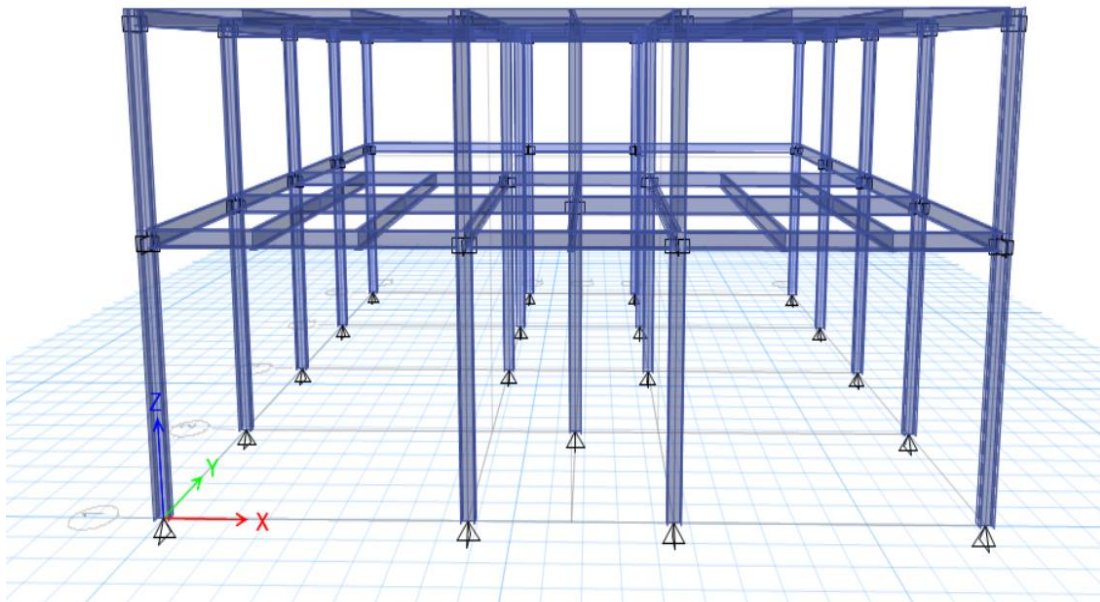

Figure 30 ETABS 3D drawing

3.3.1 Mezzanine floor beam (Girder 2-2):

- **Input:**

Ultimate load is applied on the mezzanine floor beam using calculation and SkyCiv program. The beam is fixed at both ends. The length of the beam is 12.00 meters. The drawing shows the length of the beam, applied load, and supports.

Table 10 Mezzanine floor analysis

A- Dead Load		
A- Slab Weight =	Thickness × Space × Density =	Total
	0.25 m 6 m 2.5 t/m ³	3.75 t/m
B- Beam Weight =		0.178 t/m
C- Ceramic Tile =		0.15 t/m
Total Dead Load =		4.078 t/m
B- Live Load		
Live Load=	Load × Space =	Total
	0.5 t/m ² 6 m	3.0 t/m
C- Ultimated Load		
Wu =	1.2 × D.L + 1.6 × L.L =	Total
		9.69 t/m

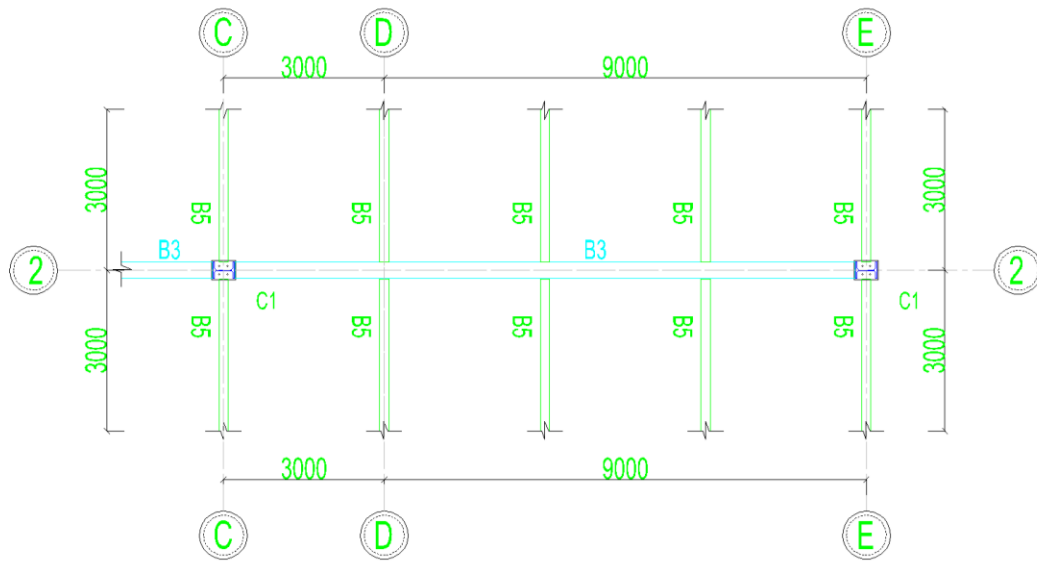

Figure 31 AutoCAD Drawing, for Grade 2 - Level 7m

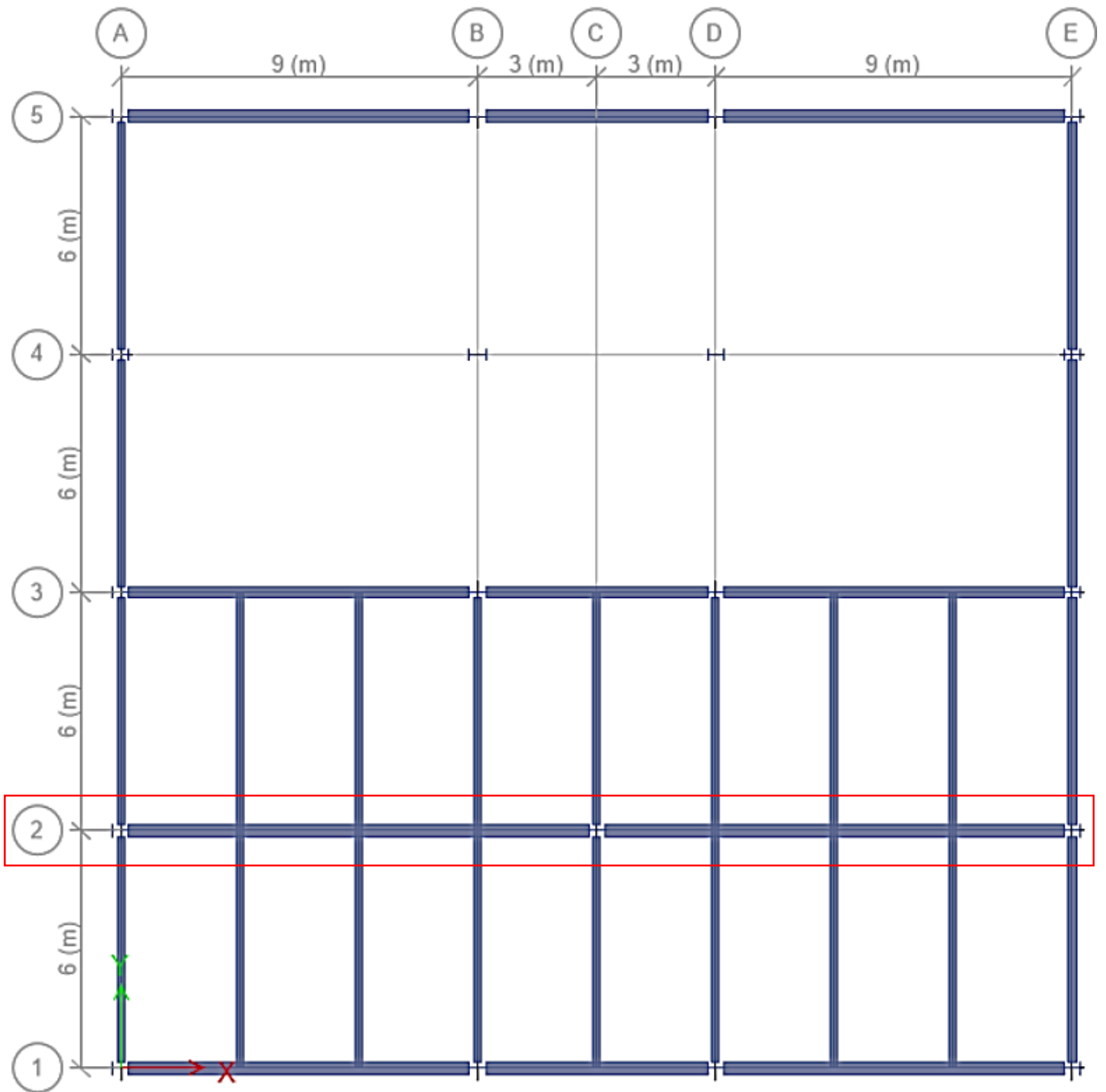

Figure 32 ETABS drawing, mezzanine floor, Girder 2

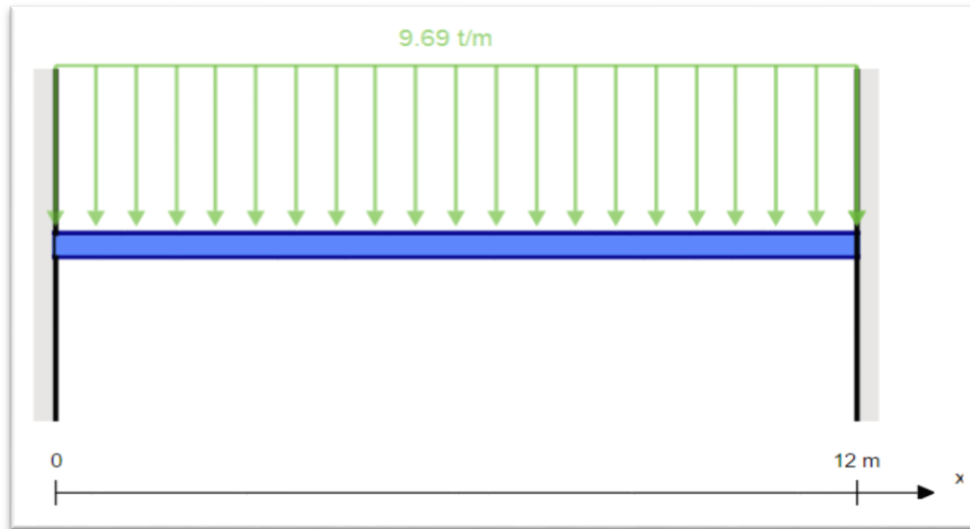

Figure 33 Input data from SkyCiv program for mezzanine floor beam

- **Output:**

Output data are the results of the structural analysis of the mezzanine floor beam using calculation and SkyCiv program. The following tables summarize the calculations of the reactions forces of the beam.

Table 11 Structural analysis for girder 2

Calculate for Moment
$M_{\max(\text{End})} = \frac{W_u \times L^2}{12} = \frac{9.69 \times 12^2}{12} = 116.32 \text{ t-m}$
$M_{\max(\text{Cen})} = \frac{W_u \times L^2}{24} = \frac{9.69 \times 12^2}{24} = 58.16 \text{ t-m}$
Calculate for Maximum Shear (V_{\max})
$V_{\max} = \frac{W_u \times L}{2} = \frac{9.69 \times 12}{2} = 58.16 \text{ t}$

Free Body Diagram (FBD)

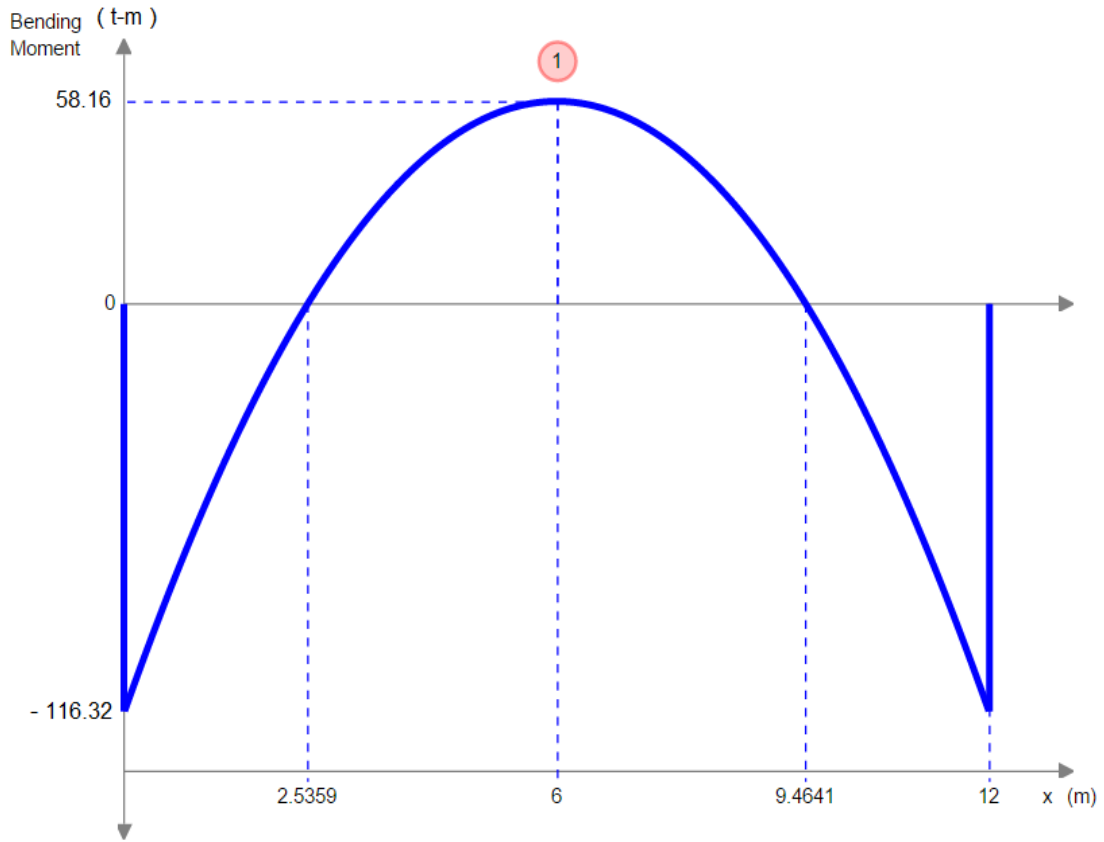
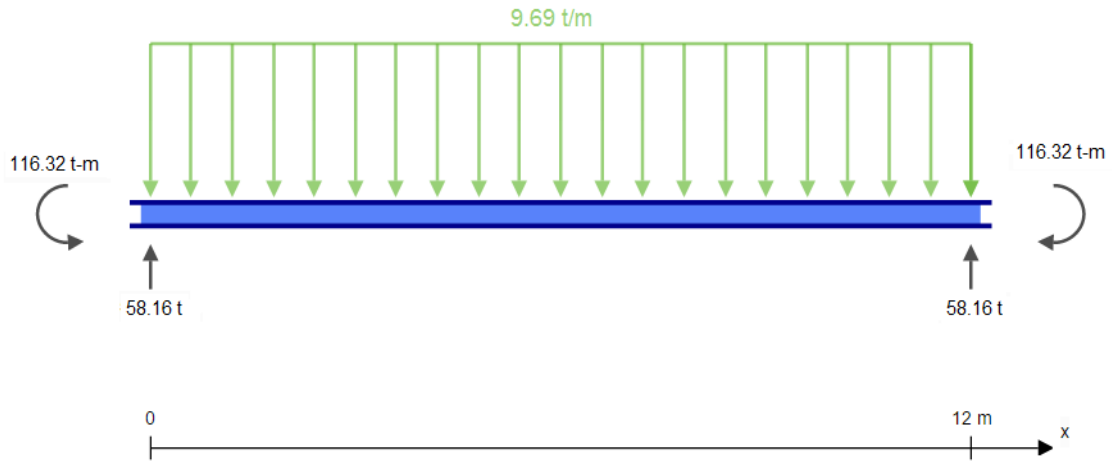

Figure 34 Output data from SkyCiv program (moment)

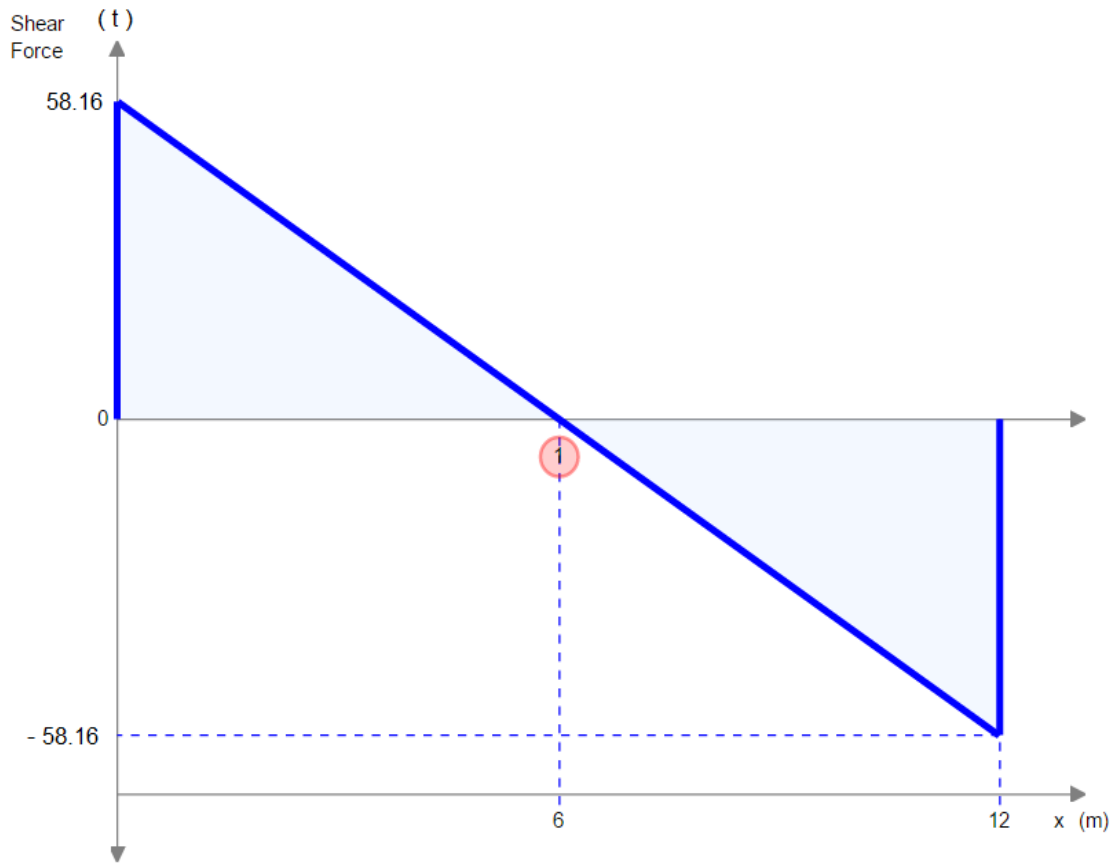

Figure 35 Output data from SkyCiv program (shear)

3.3.2 Roof beam (3DE):

- **Input:**

Ultimate load is applied on the roof beam using calculation and SkyCiv program. The beam is fixed at both ends. The length of the beam is 9.00 meters. The drawing shows the length of the beam, applied load, and supports.

Table 12 Roof analysis for 3DE beam

A- Dead Load		
A- Slab Weight =	Thickness × Space × Density =	Total
	0.25 m 6 m 2.5 t/m ³	3.75 t/m
B- Beam Weight =		0.125 t/m
C- Ceramic Tile =		0.15 t/m
Total Dead Load =		4.025 t/m
B- Live Load		
Live Load=	Load × Space =	Total
	0.25 t/m ² 6 m	1.5 t/m
C- Ultimated Load		
Wu =	1.2 × D.L + 1.6 × L.L =	Total
		7.23 t/m

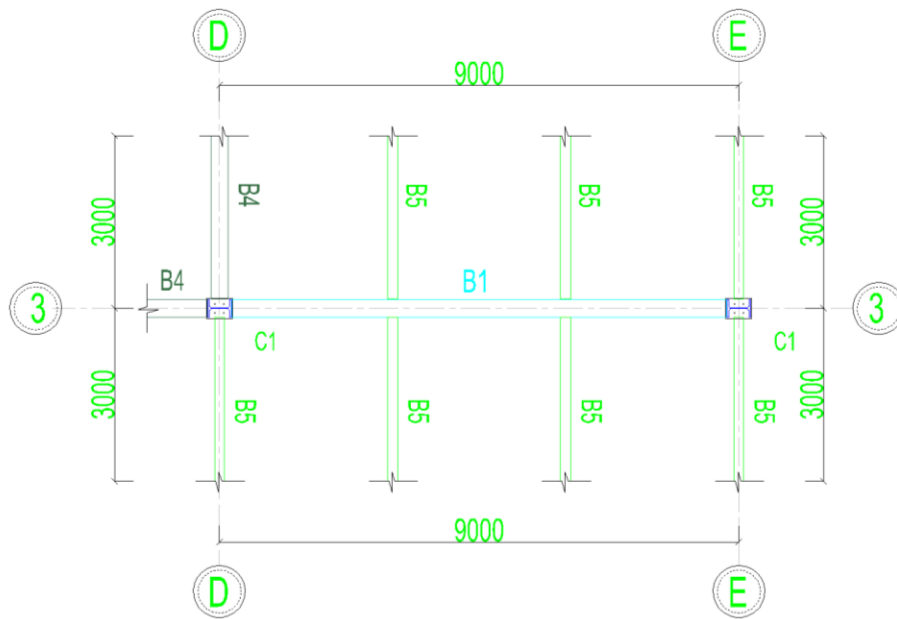

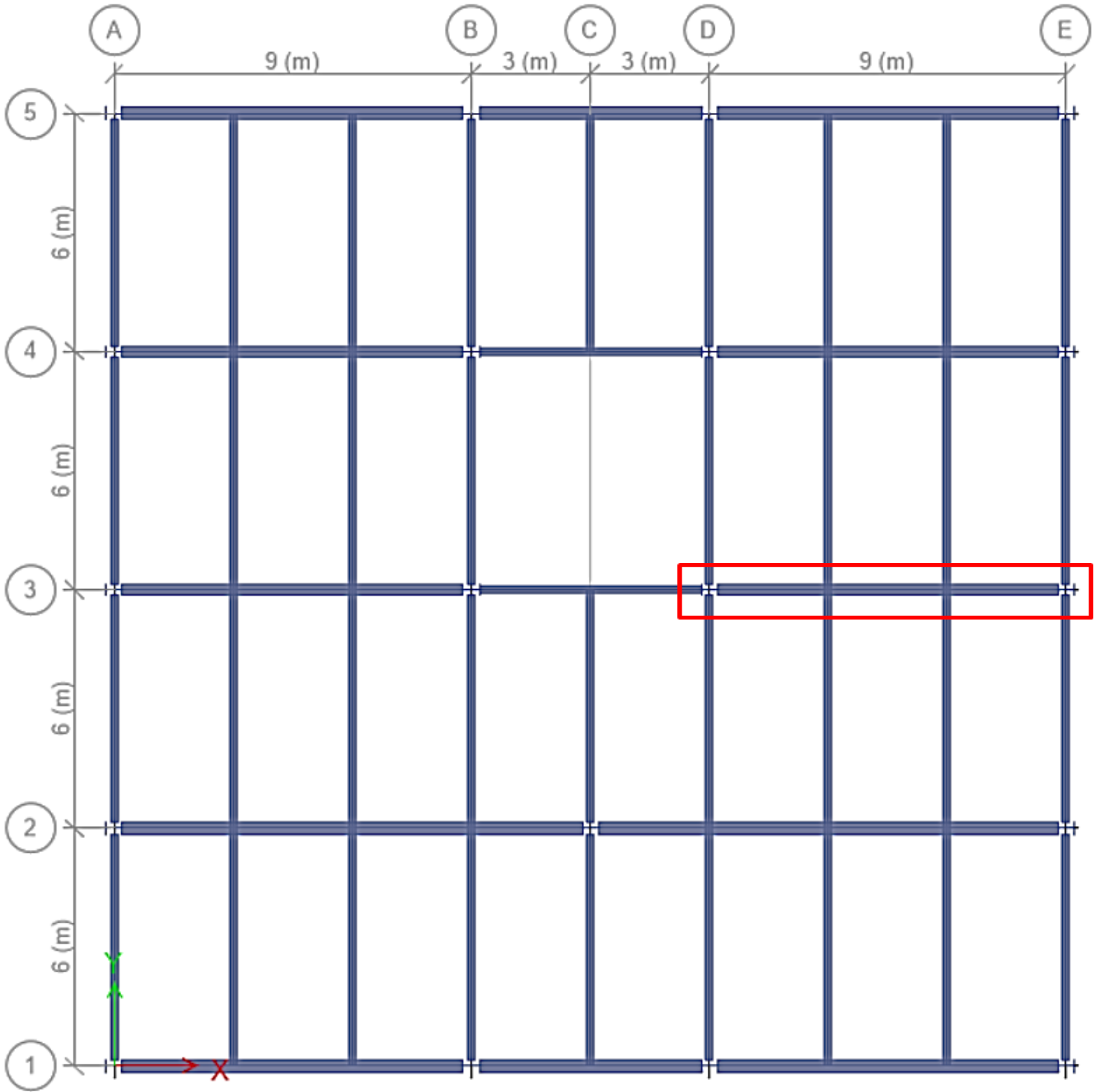

Figure 36 ETABS drawing, Roof, 3DE.

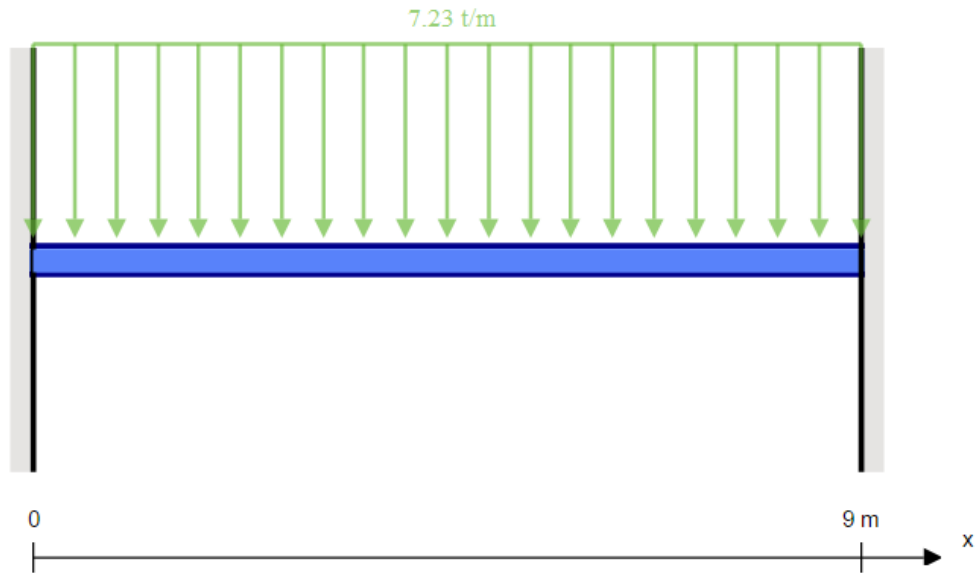

Figure 37 Input data from SkyCiv program for Roof beam

- **Output:**

Output data are the results of the structural analysis of the roof beam using calculation and SkyCiv program. The following tables summarize the calculations of the reactions forces of the beam.

Table 13 Structural analysis for 3DE beam

Calculate for Moment	
$M_{\max(\text{End})} = \frac{W_u \times L^2}{12} = \frac{7.23 \times 9^2}{12} =$	48.80 t-m
$M_{\max(\text{Cen})} = \frac{W_u \times L^2}{24} = \frac{7.23 \times 9^2}{24} =$	24.40 t-m

Calculate for Maximum Shear (V_{\max})	
$V_{\max} = \frac{W_u \times L}{2} = \frac{7.23 \times 9}{2} =$	32.54 t

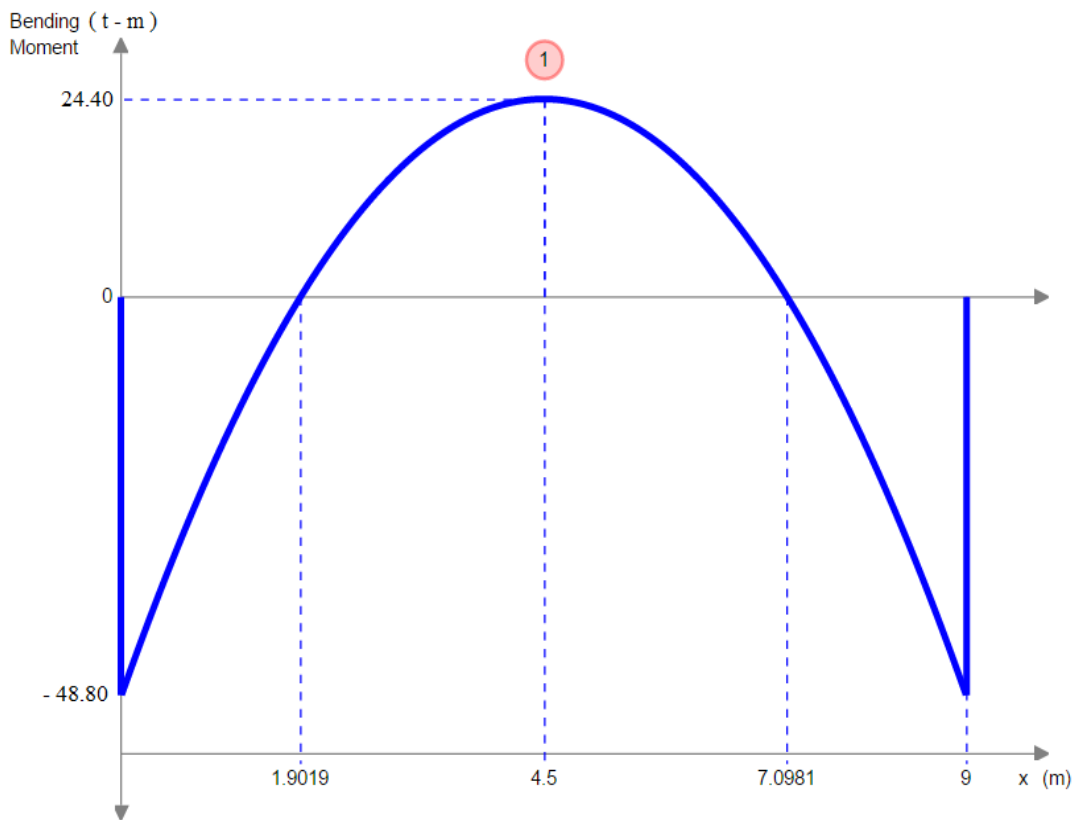
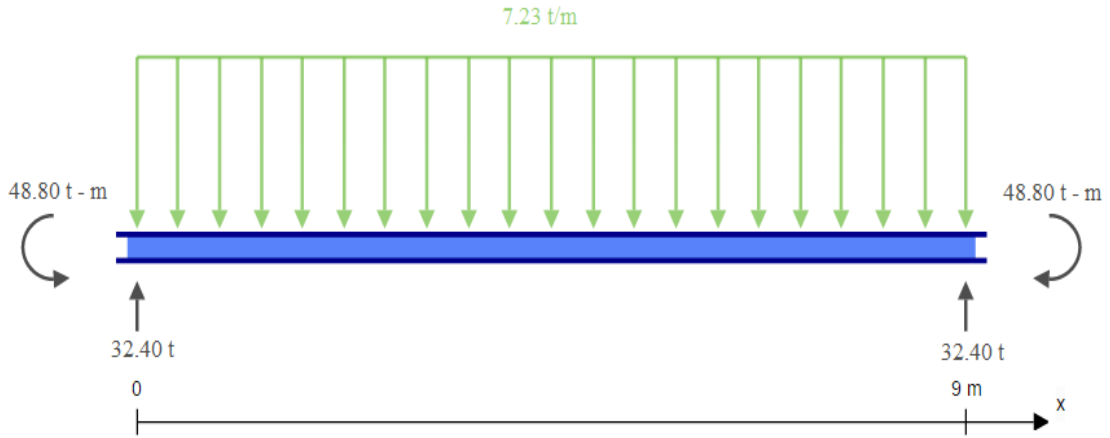

Figure 38 Output data from SkyCiv program (moment)



Figure 39 Output data from SkyCiv program (shear)

3.3.3 Dome beam (3BD):

- **Input:**

Ultimate load is applied on the dome beam using calculation and SkyCiv program. The beam is fixed at both ends. The length of the beam is 6.00 meters. The drawing shows the length of the beam, applied load, and supports. The dome weight is calculated and applied in the beam structural analysis to be used in dome beam design.

Table 14 Roof analysis for dome beam

A- Dead Load (Distribuded Load)		
A- Slab Weight =	Thickness × Space × Density =	Total
	0.25 m 3 m 2.5 t/m ³	1.88 t/m
B- Beam Weight =		0.078 t/m
Total Dead Load =		1.953 t/m
Dome Load		
Dome Weight (P.L) =	1.2 × Weight =	Total
P.L =	1.2 17.1 t/m	20.52 t/m
The Weight of Dome are Dead Point Load Acting on the Centar of The Beam		
B- Live Load		
Live Load=	Load × Space =	Total
	0.25 t/m ² 3 m	0.8 t/m
C- Ultimted Load		
Wu =	1.2 × D.L + 1.6 × L.L =	Total
		3.54 t/m

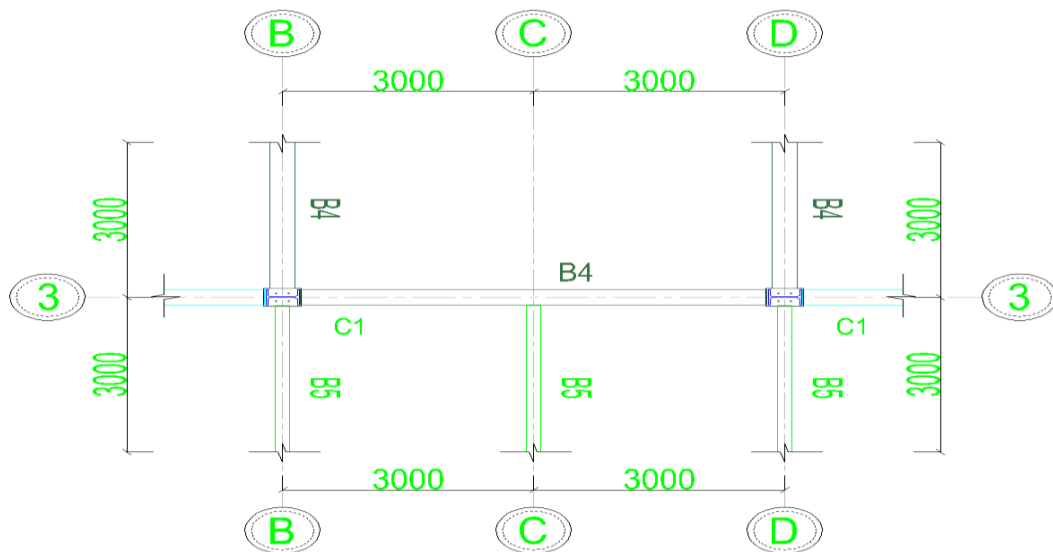

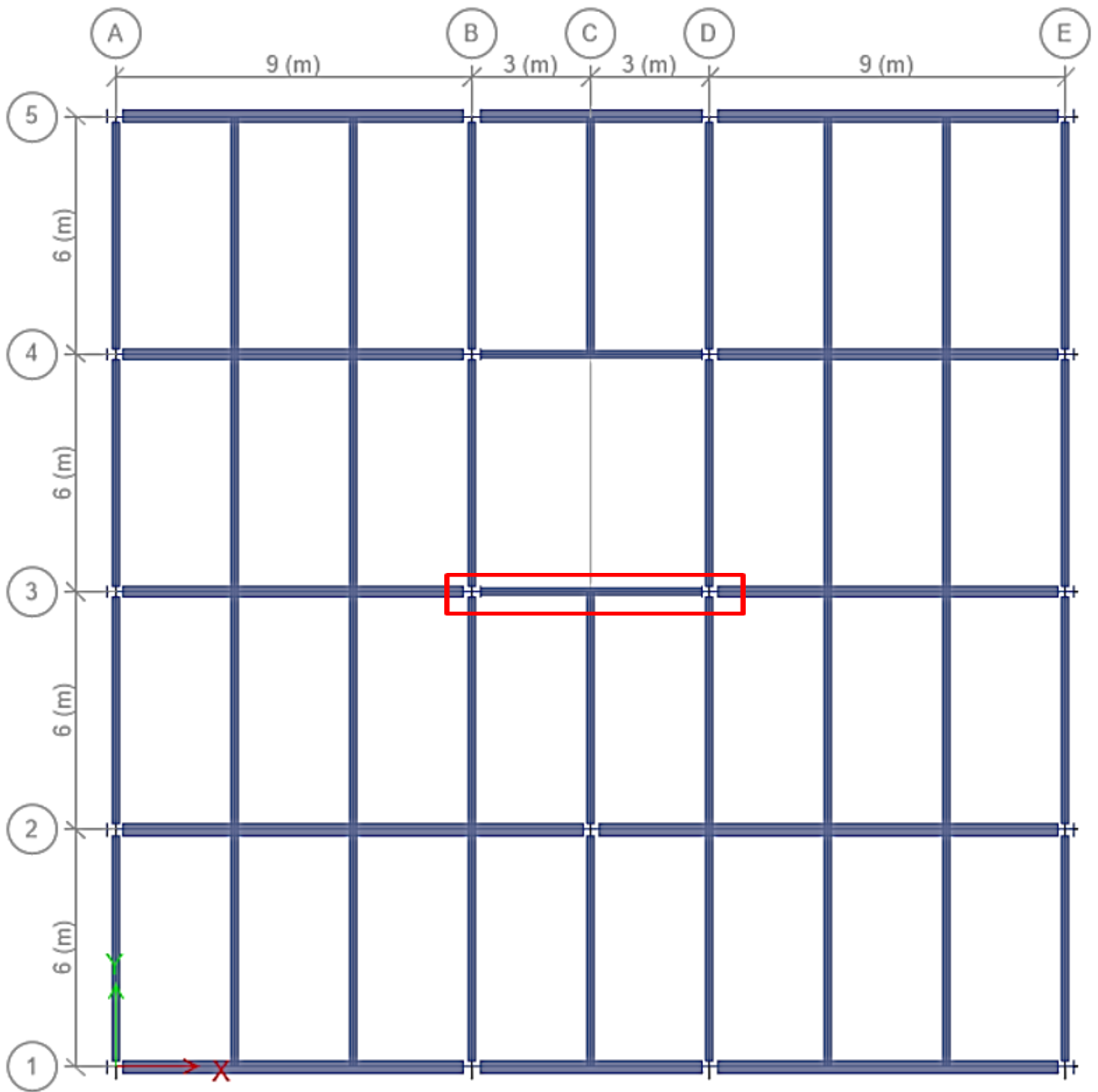

Figure 40 ETABS drawing, Dome Beam (3BD).

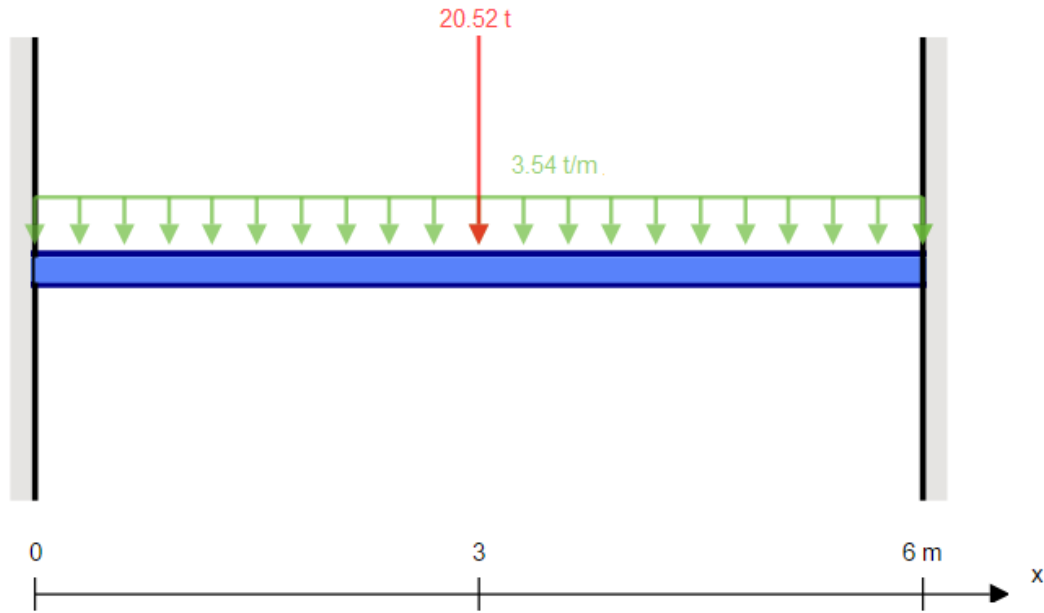

Figure 41 Input data from SkyCiv program for Dome beam

- **Output:**

Output data are the results of the structural analysis of the dome beam using calculation and SkyCiv program. The following tables summarize the calculations of the reactions forces of the beam.

Table 15 Structural analysis for 3BD beam

$R_1 = \frac{W_u \times L}{2} + \frac{P.L}{2} =$ $R_1 = \frac{3.54 \times 6}{2} + \frac{20.52}{2} = 20.88 \text{ t}$	$R_2 = \frac{W_u \times L}{2} + \frac{P.L}{2} =$ $R_2 = \frac{3.54 \times 6}{2} + \frac{20.52}{2} = 20.88 \text{ t}$
--	--

$$M_{\max(\text{both Ends})} = \frac{W_u \times L^2}{12} + \frac{P.L \times L}{8} =$$

$$M_{\max(\text{both Ends})} = \frac{3.54 \times 6^2}{12} + \frac{20.52 \times 3}{8} = 26.01 \text{ (t - m)}$$

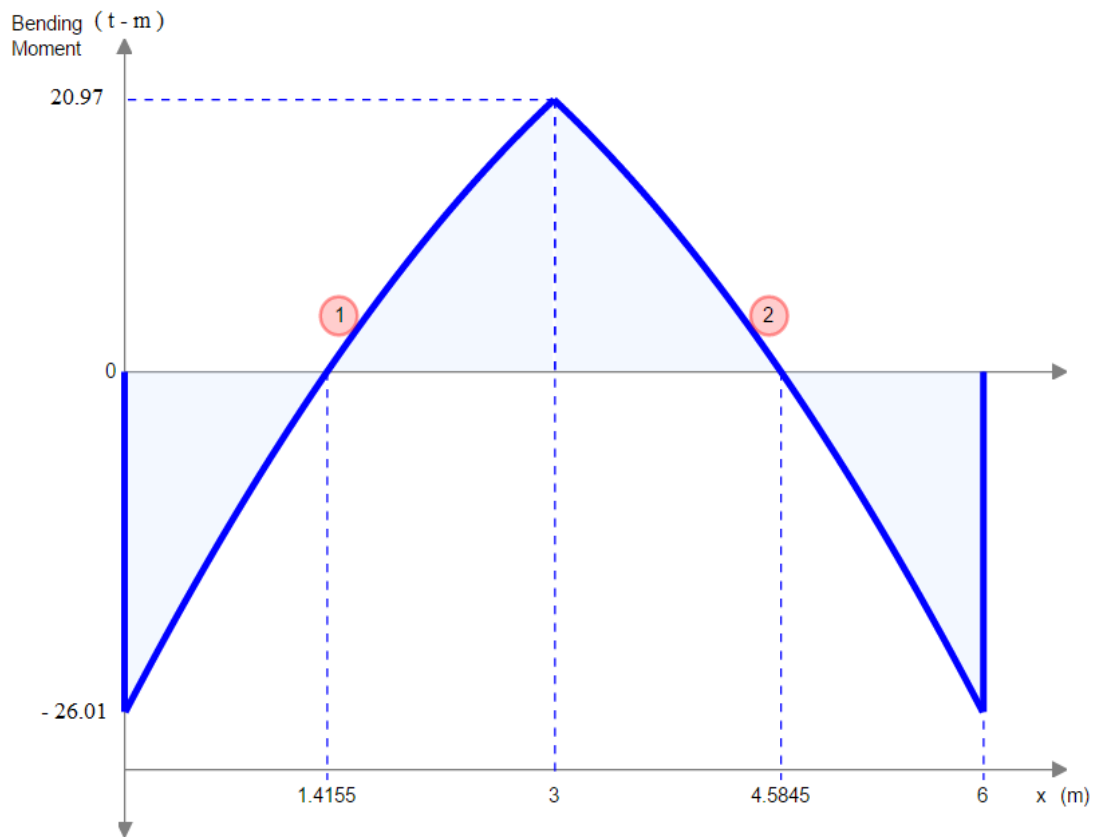
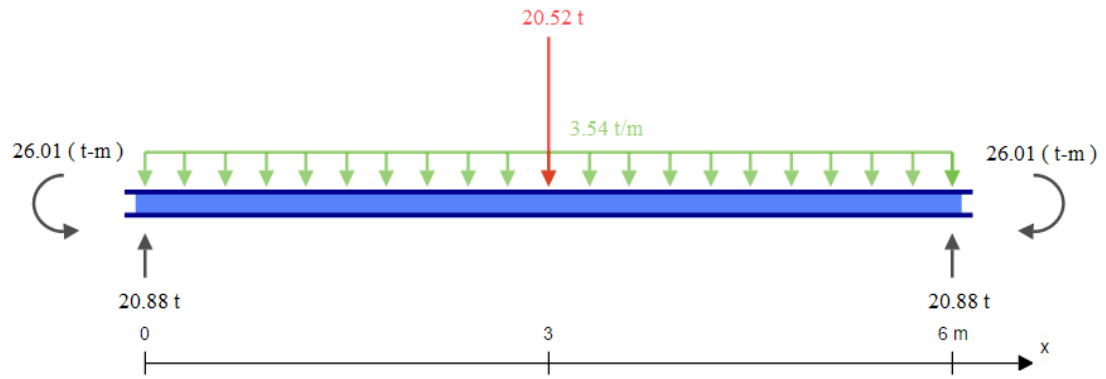

Figure 42 Output data from SkyCiv program (moment)

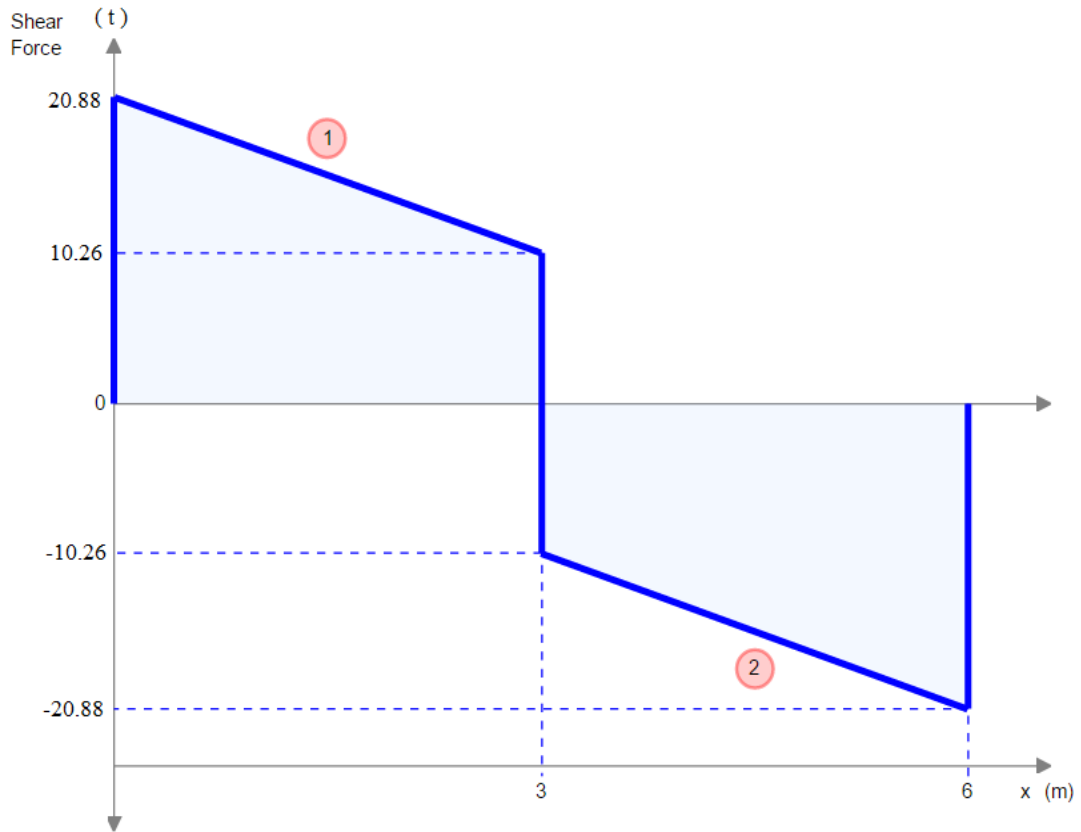

Figure 43 Output data from SkyCiv program (shear)

3.3.4 Column (2C):

- **Input:**

For column analysis, calculation would include the load combination. Using these load combinations, they will be used to do the moment calculation and shear.

Table 16 Structural analysis for column

A- Dead Load		
A- Slab Weight =	Thickness × Area × Density =	Total
=	$0.25 \text{ m} \times (6 \text{ m} \times 3 \text{ m}) \times 2.5 \text{ t/m}^3 =$	11 t
B- Beam Weight =	$0.187 \text{ t/m} \times (6 \text{ m} + 3 \text{ m}) =$	1.68 t
C- Column Weight =	$0.125 \text{ t/m} \times (6 \text{ m} + 3 \text{ m}) =$	1.13 t
D- Ceramic Tile =	$0.15 \text{ t/m} \times (6 \text{ m} + 3 \text{ m}) =$	1.35 t
Total Dead Load =		15.41 t
B- Live Load		
Live Load=	Load × Area =	Total
=	$0.5 \text{ t/m}^2 \times (6 \text{ m} \times 3 \text{ m}) =$	9.0 t
C- Ultimted Load		
$W_u =$	$1.2 \times \text{D.L} + 1.6 \times \text{L.L} =$	Total
		32.89 t
Combined the Point Load From First Floor and Roof		
First Floor Load + Roof Load =		Total
=	$32.89 \text{ t} + 32.89 \text{ t} =$	65.78 t

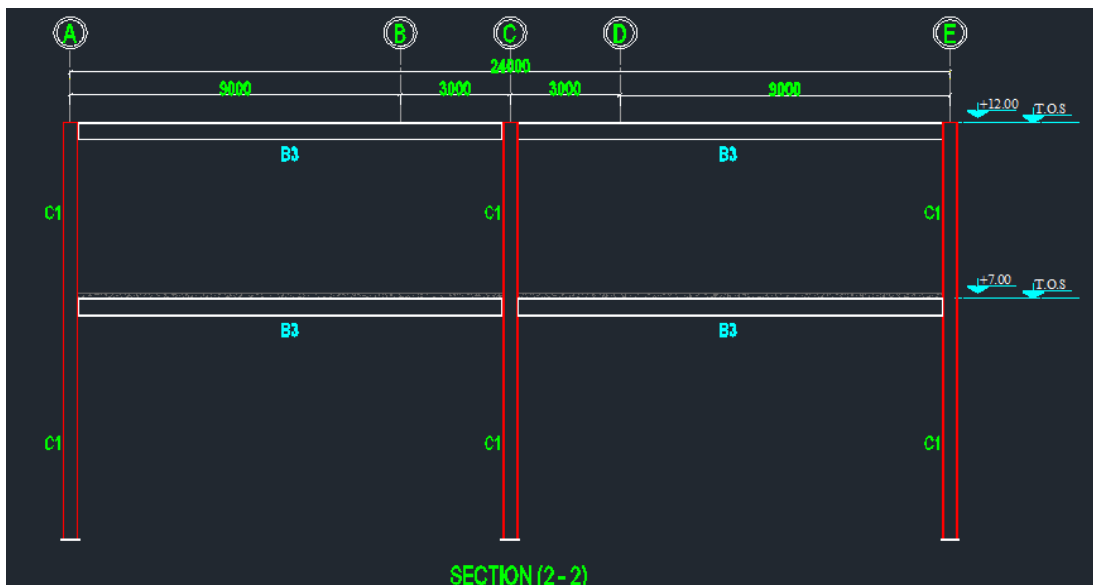

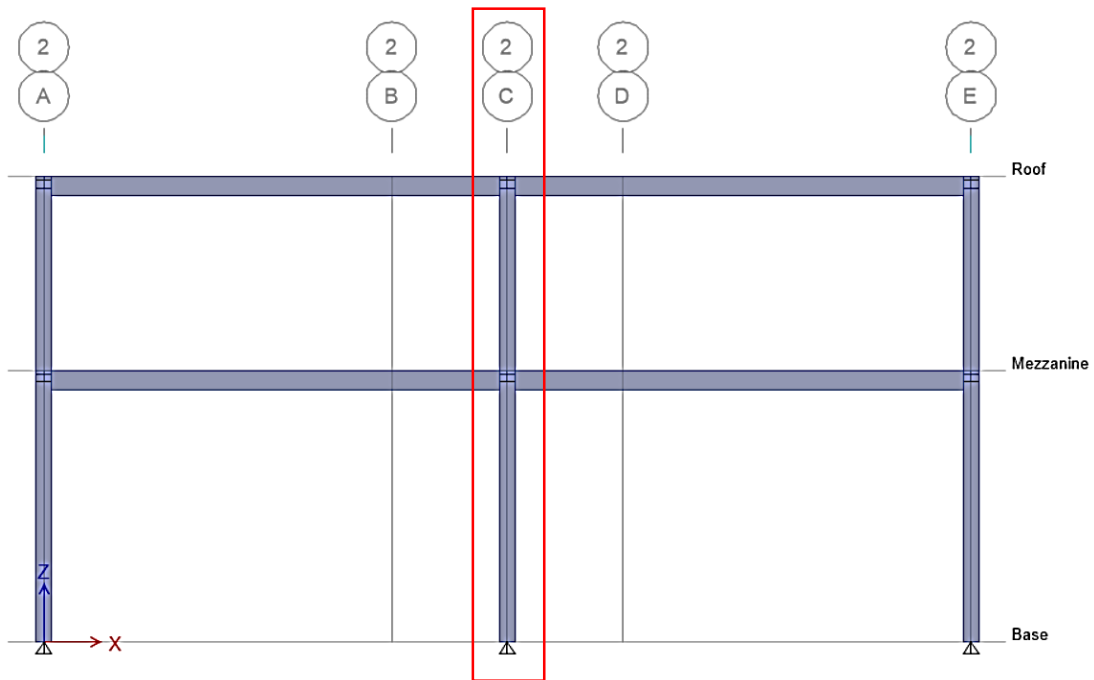

Figure 44 ETABS drawing, Column 2C

Output:

Output data are the results of the structural analysis of Column calculation. The following tables summarize the calculations of the reactions forces of the column.

Table 17 Structural analysis for column

Calculate for Moment	
$M_{\max(\text{End})} = \frac{W_u \times L^2}{12} = \frac{65.78 \times 7^2}{12} =$	268.60 t-m
$M_{\max(\text{Cen})} = \frac{W_u \times L^2}{24} = \frac{65.78 \times 7^2}{24} =$	134.30 t-m

Calculate for Maximum Shear (V_{\max})	
$V_{\max} = \frac{W_u \times L}{2} = \frac{7.23 \times 9}{2} =$	32.54 t

3.4 Design:

According to the structural analysis, the most critical analysis is the mezzanine floor beam analysis. Its moment, shear, and reactions are the most critical. These data will be used to design the mezzanine and roof beam. Dome beam and column have its own different output reaction.

The steel sections are taken from European Specifications Beams (EURONORM). For moment, shear, and deflection calculations, American Institute of Steel Construction (AISC) Manual of Steel Construction for Load and Resistance Factor Design (LRFD) is applied.

Selected steel section is shown in tables. These data are taken from the steel section properties, ETABS software during the modeling phase, and the American Building code equations. ETABS output will be included with the appendix.

Moment design will include the lateral-torsional buckling design. Accordingly, this will check the beam length if it is safe against lateral-torsional buckling. In next step, the nominal moment for the selected steel section will be calculated to check and compare it with the ultimate moment from the structural analysis.

Shear design will include web condition of the section. This will determine the web shearing strength of the selected section. Next step, the area for the web will be calculated to use it in nominal shear equation. In nominal shear, it will show the capability of the selected steel section against the ultimate shear that has been mentioned previously in the structural analysis.

Deflection check is the check of the maximum allowable deflection of the structure according to the building code with the deflection of the selected steel section. The deflection limit is calculated according to the American Building Code.

This section will show four designs: Mezzanine beam, roof beam, dome beam, and column. Each member will have the properties of the selected steel section, moment design, shear design, and deflection check.

3.4.1 Mezzanine beam design (Girder 2-2):

- Properties:

Table 18 Steel section properties (HE 500 B)

Section Property (HE500B)								
A_g	0.0239	m^2	S_x	0.004287	m^3	C_w	0.000007018	m^6
b	0.3	M	S_y	0.000842	m^3	J	0.000005	m^4
d	0.39	M	r_x	0.212	m	L	12	m
h_o	0.42	M	r_y	0.0727	m	\emptyset_b	0.9	-
h	0.5	M	t_w	0.0145	m	\emptyset_v	1	-
I_x	0.001072	m^4	t_r	0.028	m	K_v	5	-
I_y	0.000126	m^4	F_y	35153.48	t/m^2	C_b	1.14	-
Z_x	0.004815	m^3	F_u	45700	t/m^2	C_v	1	-
Z_y	0.001292	m^3	E	20389019.16	t/m^2	C	1	-
Steel Section			ETABS Software			Building Code		

Note:

The data that are shown in blue are taken from the steel section properties, European Specifications Beams (EURONORM).

The data that are shown in green are taken from the ETABS software during the modeling phase.

The data that are shown in red are taken from the American Building Code according to its equations.

- **Moment design:**

1- Lateral-Torsional Buckling	
$L_b = L - [(0.211 \times L) \times 2]$ $L_b = 12 - [(0.211 \times 12) \times 2] = 6.94 \text{ m}$	
$L_p = 1.76 \times r_y \times \sqrt{\frac{E}{F_y}}$ $L_p = 1.76 \times 0.0727 \times \sqrt{\frac{20389019.2}{35153.48}} = 3.08 \text{ m}$	
$L_r = 1.95 \times r_{ts} \times \frac{E}{0.7 \times F_y} \times \sqrt{\frac{J \times c}{S_x \times h_o} + \sqrt{\left(\frac{J \times c}{S_x \times h_o}\right)^2 + 6.76 \left(\frac{0.7 \times F_y}{E}\right)^2}}$ $L_r = 1.95 \times 0.083 \times \frac{20389019.16}{0.7 \times 35153.48} \times \sqrt{\frac{0.000005 \times 1}{0.004287 \times 0.42} + \sqrt{\left(\frac{0.000005 \times 1}{0.004287 \times 0.42}\right)^2 + 6.76 \left(\frac{0.7 \times 35153.48}{20389019.16}\right)^2}} = 11.24 \text{ m}$	
$r_{ts} = \sqrt{\frac{\sqrt{I_y C_w}}{S_x}}$ $r_{ts} = \sqrt{\frac{\sqrt{0.000126 \times 0.000007018}}{0.004287}} = 0.083 \text{ m}$	

2- The Case for Lateral-Torsional Bucking						
a) $L_b \leq L_p$	6.94 m	≤	3.08 m		✘	
b) $L_p < L_b \leq L_r$	3.08 m	<	6.94 m	≤	11.24 m	✔
c) $L_b > L_r$	6.94 m	>	11.24 m		✘	

3- Value Of Plastic Bending Moment and Nominal Flexure Strength

$$M_p = F_y \times Z_x = 35153.48 \times 0.004815 = 169.26 \text{ t/m}$$

$$M_n = C_b \left[M_p - (M_p - 0.7F_y S_x) \left(\frac{L_b - L_p}{L_r - L_p} \right) \right]$$

$$M_n = 1.14 \times \left[169.26 - (169.26 - 0.7 \times 35153.48 \times 0.004287) \left(\frac{6.94 - 3.08}{11.24 - 3.08} \right) \right] = 158.60 \text{ t/m}$$

4- Check for the Moment

$$M_u = 116.3 \text{ t/m}$$

$$\phi_b M_n = 142.74 \text{ t/m}$$

$$M_u \leq \phi_b M_n$$

$$116.3 \text{ t/m} \leq 142.74 \text{ t/m}$$



$$M_u \leq \phi_b M_n$$

- Shear design:

1- Check for Web Shear Conditions (C_v)

$$\frac{h}{t_w} = \frac{0.5}{0.0145} = 34.48$$

$$1.10 \sqrt{\frac{k_v \times E}{F_y}}$$

$$1.10 \times \sqrt{\frac{5 \times 20389019.2}{35153.48}} = 59.24$$

$$\frac{h}{t_w} \leq 1.10 \sqrt{\frac{k_v \times E}{F_y}}$$

34.48

≤

59.24



2- Find Web Area (A_w)

$$A_w = d \times t_w = 0.39 \times 0.0145 = 0.00566 \text{ m}^2$$

3- Find Nominal Shear (V_n)

$$V_n = 0.6 \times F_y \times A_w \times C_v$$

$$V_n = 0.6 \times 35153.48 \times 0.00566 \times 1 = 119.28 \text{ t}$$

4- Check for Shear

$$\phi_v V_n = 119.28 \text{ t}$$

$$V_u \leq \phi_v V_n$$
$$58.16 \text{ t} \leq 119.28 \text{ t}$$



- Deflection Check:

Check for Deflection (Δ)			
$\Delta_{\max} = \frac{L}{240} = \frac{12000}{240} =$	50 mm		
$\Delta_{\text{act}} = \frac{W_u \times L^4}{384 \times E \times I_x} = \frac{9.69 \times 12^4}{384 \times 20389019.16 \times 0.001072} =$	24 mm		
$\Delta_{\text{act}} < \Delta_{\max}$	24 mm < 50 mm	✓	

Accordingly, the selected steel section for the mezzanine beam is HE 500 B. This section is safe against moment, shear, and deflection limit.

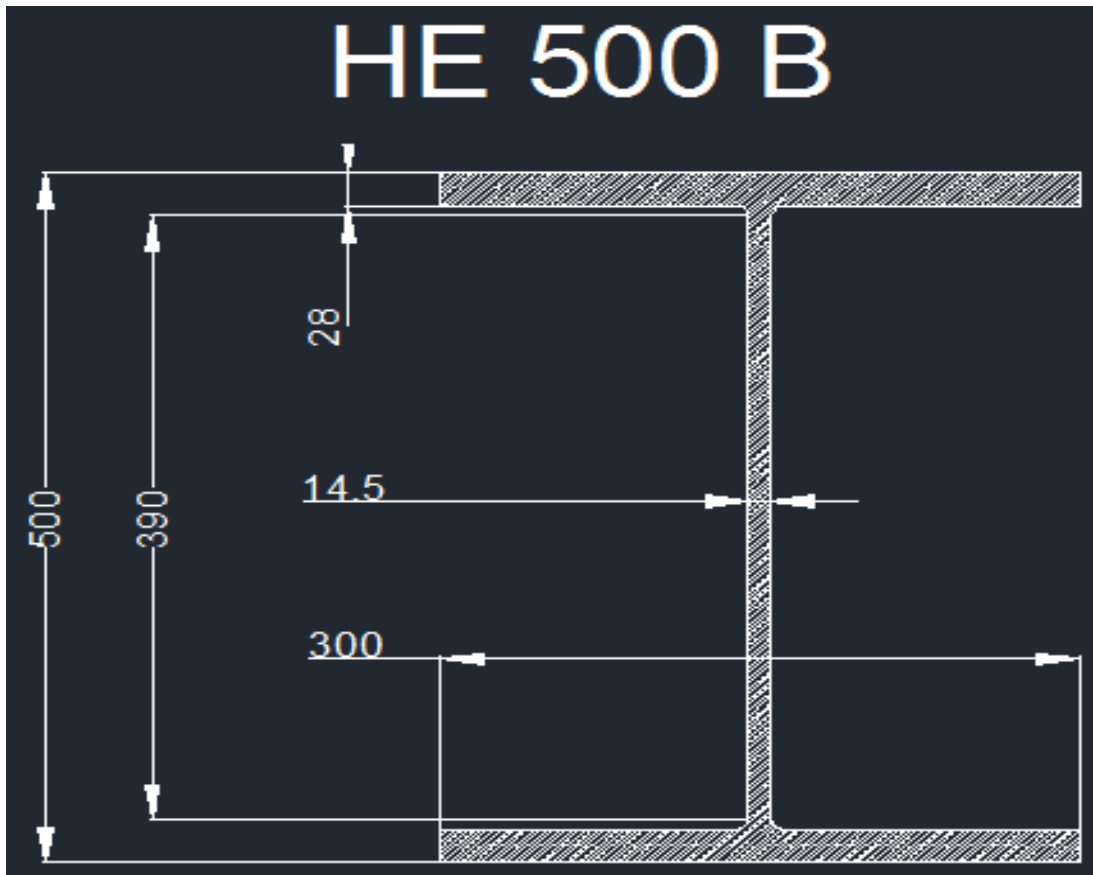

Figure 45 Steel section properties (HE 500 B)

ETABS 2015 Steel Frame Design

(Mezzanine floor beam)

AISC 360-10 Steel Section Check (Strength Summary)

Element Details

Level	Element	Location (m)	Combo	Element Type	Section	Classification
Mezzanine	B60	11.8	DStlS2	Special Moment Frame	HE500B	Compact

LLRF and Demand/Capacity Ratio

L (m)	LLRF	Stress Ratio Limit
12.00000	1	0.95

Analysis and Design Parameters

Provision	Analysis	2nd Order	Reduction
LRFD	Direct Analysis	General 2nd Order	Tau-b Fixed

Stiffness Reduction Factors

$\alpha P_r / P_y$	$\alpha P_r / P_e$	τ_b	EA factor	EI factor
0	0	1	0.8	0.8

Design Code Parameters

Φ_b	Φ_c	Φ_{TY}	Φ_{TF}	Φ_V	Φ_{V-RI}	Φ_{VT}
0.9	0.9	0.9	0.75	0.9	1	1

Section Properties

A (m ²)	J (m ⁴)	I ₃₃ (m ⁴)	I ₂₂ (m ⁴)	A _{v3} (m ²)	A _{v2} (m ²)
0.0239	0.000005	0.001072	0.000126	0.0168	0.0073

Design Properties

S ₃₃ (m ³)	S ₂₂ (m ³)	Z ₃₃ (m ³)	Z ₂₂ (m ³)	r ₃₃ (m)	r ₂₂ (m)	C _w (m ⁶)
0.004288	0.000841	0.004815	0.001292	0.21179	0.07267	7.018E-06

Material Properties

E (tonf/m²)	f_y (tonf/m²)	R_y	α
20389019.1 6	35153.48	1.1	NA

Stress Check forces and Moments

Location (m)	P_u (tonf)	M_{u33} (tonf-m)	M_{u22} (tonf-m)	V_{u2} (tonf)	V_{u3} (tonf)	T_u (tonf-m)
11.8	0	-84.99	0	40	0	0

Axial Force & Biaxial Moment Design Factors (H1-1b)

	L Factor	K₁	K₂	B₁	B₂	C_m
Major Bending	0.967	1	1	1	1	1
Minor Bending	0.25	1	1	1	1	1

Parameters for Lateral Torsion Buckling

L_{ltb}	K_{ltb}	C_b
0.25	1	1.109

Demand/Capacity (D/C) Ratio Eqn. (H1-1b)

D/C Ratio	$(P_r / 2P_c) + (M_{r33} / M_{c33}) + (M_{r22} / M_{c22})$
=	
0.558 =	0 + 0.558 + 0

Axial Force and Capacities

P_u Force (tonf)	φP_{nc} Capacity (tonf)	φP_{nt} Capacity (tonf)
0	607.22	756.15

Moments and Capacities

	M_u Moment (tonf-m)	φM_n Capacity (tonf-m)	φM_n No L_{TBD} (tonf-m)
Major Bending	84.99	152.34	152.34
Minor Bending	0	40.88	

Shear Design

	V_u Force (tonf)	ϕV_n Capacity (tonf)	Stress Ratio
Major Shear	40	152.92	0.262
Minor Shear	0	318.91	0

End Reaction Major Shear Forces

Left End Reaction (tonf)	Load Combo	Right End Reaction (tonf)	Load Combo
15.58	DStlS2	40	DStlS2

DEFLECTION DESIGN (Combo DStlD2)

Type	Consider	Deflection m	Limit m	Ratio	Status
Dead Load	Yes	0.00775	0.1	0.077	OK
Super DL + Live Load	Yes	0.01544	0.1	0.154	OK
Live Load	Yes	0.01544	0.03333	0.463	OK
Total Load	Yes	0.02319	0.05	0.464	OK
Total - Camber	Yes	0.02319	0.05	0.464	OK

3.4.2 Roof beam design (3DE):

- Properties:

Table 19 Steel section properties (HE 400 A)

Section Property (HE400A)								
A_g	0.0159	m^2	S_x	0.002311	m^3	C_w	0.000000022	m^6
b	0.3	m	S_y	0.000571	m^3	J	0.000002	m^4
d	0.298	m	r_x	0.168	m	L	9	m
h_o	0.32	m	r_y	0.0734	m	\emptyset_b	0.9	-
h	0.39	m	t_w	0.011	m	\emptyset_v	1	-
I_x	0.0004507	m^4	t_f	0.019	m	K_v	5	-
I_y	0.0000856	m^4	F_y	35153.48	t/m^2	C_b	1.14	-
Z_x	0.002562	m^3	F_u	45700	t/m^2	C_v	1	-
Z_y	0.00873	m^3	E	20389019.16	t/m^2	C	1	-
Steel Section			ETABS Software			Building Code		

Note:

The data that are shown in blue are taken from the steel section properties, European Specifications Beams (EURONORM).

The data that are shown in green are taken from the ETABS software during the modeling phase.

The data that are shown in red are taken from the American Building Code according to its equations.

- **Moment design:**

1- Lateral-Torsional Bukling	
$L_b = L - [(0.211 \times L) \times 2]$ $L_b = 9 - [(0.211 \times 9) \times 2] = 5.20 \text{ m}$	
$L_p = 1.76 \times r_y \times \sqrt{\frac{E}{F_y}}$ $L_p = 1.76 \times 0.0734 \times \sqrt{\frac{20389019}{35153.48}} = 3.11 \text{ m}$	
$L_r = 1.95 \times r_{ts} \times \frac{E}{0.7 \times F_y} \times \sqrt{\frac{J \times c}{S_x \times h_o} + \sqrt{\left(\frac{J \times c}{S_x \times h_o}\right)^2 + 6.76 \left(\frac{0.7 \times F_y}{E}\right)^2}}$ $L_r = 1.95 \times 0 \times \frac{20389019.16}{0.7 \times 35153.48} \times \sqrt{\frac{0.000002 \times 1}{0.002311 \times 0.3} + \sqrt{\left(\frac{0.000002 \times 1}{0.002311 \times 0.32}\right)^2 + 6.76 \left(\frac{0.7 \times 35153.48}{20389019.16}\right)^2}} = 3.26 \text{ m}$	
$r_{ts} = \sqrt{\frac{I_y C_w}{S_x}}$ $r_{ts} = \sqrt{\frac{0.0000856 \times 0.000000022}{0.002311}} = 0.02 \text{ m}$	

2- The Case for Lateral-Torsional Bukling					
a) $L_b \leq L_p$	5.20 m	\leq	3.11 m		✘
b) $L_p < L_b \leq L_r$	3.11 m	$<$	5.20 m	\leq	3.26 m ✘
c) $L_b > L_r$	5.20 m	$>$	3.26 m		✔

3- Find Buckling Stress

$$F_{cr} = \frac{C_b \pi^2 E}{\left(\frac{L_b}{r_{ts}}\right)^2} \times \sqrt{1 + 0.078 \times \frac{Jc}{S_x h_o} \times \left(\frac{L_b}{r_{ts}}\right)^2}$$

$$F_{cr} = \frac{1.14 \times 3.142^2 \times 20389019.16}{\left(\frac{5.20}{0.02}\right)^2} \times \sqrt{1 + 0.078 \times \frac{0.000002 \times 1}{0.002311 \times 0.32} \times \left(\frac{5.20}{0.02}\right)^2} = 16399.60 \quad \text{t/m}^2$$

4- Nominal Moment

$$M_p = F_y \times Z_x = 35153.48 \times 0.00256 = 90.06 \quad \text{t/m}$$

$$M_n = F_{cr} \times S_x = 16399.60 \times 0.00231 = 37.90 \quad \text{t/m}$$

5- Check for the Moment

$$M_n \leq M_p$$

$$M_n \leq M_p$$

$$37.90 \text{ t/m} \leq 90 \text{ t/m}$$



- Shear design:

1- Check for Web Shear Conditions (C_v)

$$\frac{h}{t_w} = \frac{0.39}{0.011} = 35.45$$

$$1.10 \sqrt{\frac{k_v \times E}{F_y}}$$

$$1.10 \times \sqrt{\frac{5 \times 20389019.16}{35153.48}} = 59.24$$

$$\frac{h}{t_w} \leq 1.10 \sqrt{\frac{k_v \times E}{F_y}}$$

35.45

≤

59.24



2- Find Web Area (A_w)

$$A_w = d \times t_w = 0.298 \times 0.011 = 0.003278 \text{ m}^2$$

3- Find Nominal Shear (V_n)

$$V_n = 0.6 \times F_y \times A_w \times C_v$$

$$V_n = 0.6 \times 35153.48 \times 0.003278 \times 1 = 69.14 \text{ t}$$

4- Check for Shear

$$\phi_v V_n = 69.14 \text{ t}$$

$$V_u \leq \phi_v V_n$$
$$32.54 \text{ t} \leq 69.14 \text{ t}$$



- Deflection Check:

Check for Deflection (Δ)			
$\Delta_{\max} = \frac{L}{240} = \frac{9}{240} = 38 \text{ mm}$			
$\Delta_{\text{act}} = \frac{W_u \times L^4}{384 \times E \times I_x} = \frac{7.23 \times 9^4}{384 \times 20389019.16 \times 0.0004507} = 13 \text{ mm}$			
Δ_{act} 13 mm	<	Δ_{\max} 38 mm	✓

Accordingly, the selected steel section for the roof beam is HE 400 A. This section is safe against moment, shear, and deflection limit.

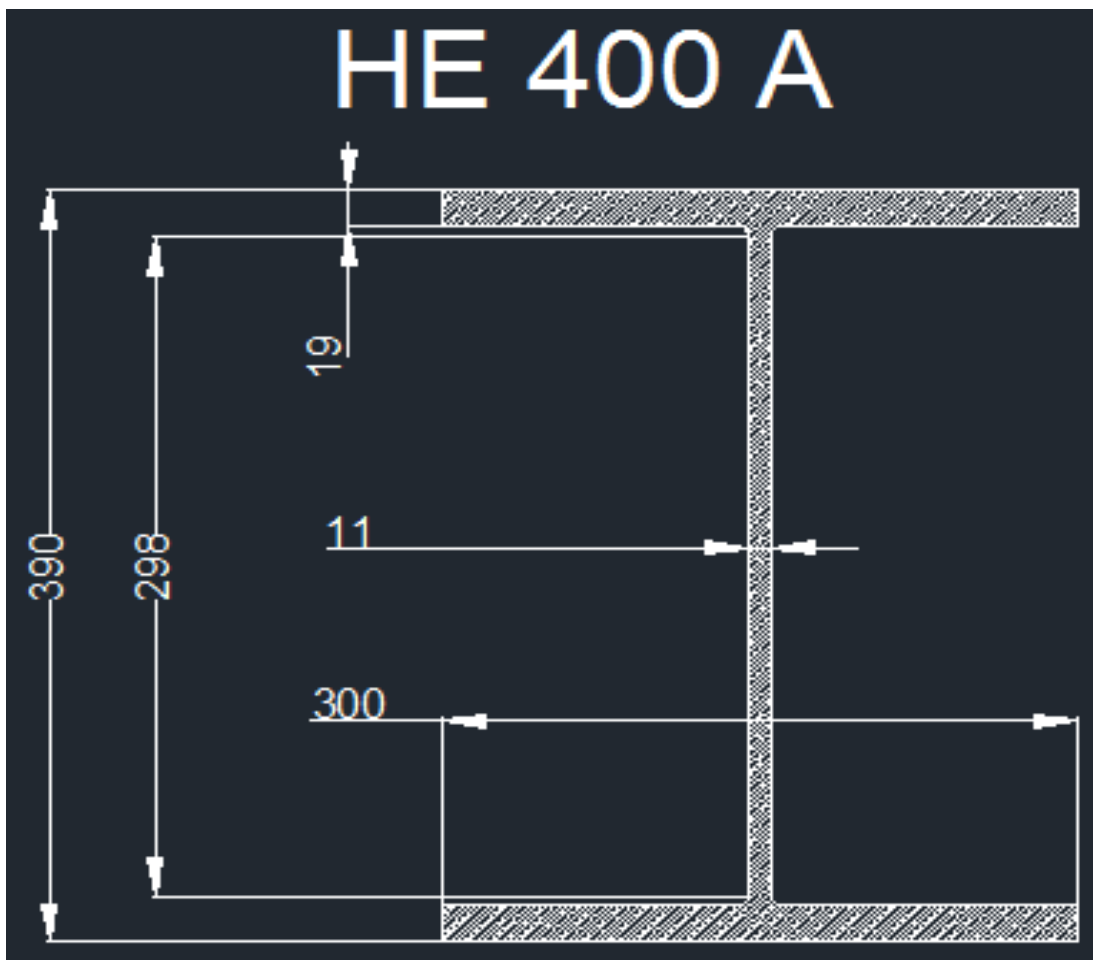

Figure 46 Steel section properties (HE 400 A)

ETABS 2015 Steel Frame Design

(Roof beam)

AISC 360-10 Steel Section Check (Strength Summary)

Element Details

Level	Element	Location (m)	Combo	Element Type	Section	Classification
Mezzanine	B51	8.8	DStlS2	Special Moment Frame	HE400 A	Compact

LLRF and Demand/Capacity Ratio

L (m)	LLRF	Stress Ratio Limit
9.00000	1	0.95

Analysis and Design Parameters

Provision	Analysis	2nd Order	Reduction
LRFD	Direct Analysis	General 2nd Order	Tau-b Fixed

Stiffness Reduction Factors

$\alpha P_r / P_y$	$\alpha P_r / P_e$	τ_b	EA factor	EI factor
0	0	1	0.8	0.8

Design Code Parameters

Φ_b	Φ_c	Φ_{TY}	Φ_{TF}	Φ_V	Φ_{V-RI}	Φ_{VT}
0.9	0.9	0.9	0.75	0.9	1	1

Section Properties

A (m ²)	J (m ⁴)	I ₃₃ (m ⁴)	I ₂₂ (m ⁴)	A _{v3} (m ²)	A _{v2} (m ²)
0.0159	0.000002	0.000451	0.000086	0.0114	0.0043

Design Properties

S ₃₃ (m ³)	S ₂₂ (m ³)	Z ₃₃ (m ³)	Z ₂₂ (m ³)	r ₃₃ (m)	r ₂₂ (m)	C _w (m ⁶)
0.002311	0.000571	0.002562	0.000873	0.16836	0.07339	0

Material Properties

E (tonf/m ²)	f _y (tonf/m ²)	R _y	α
20389019.1 6	35153.48	1.1	NA

Stress Check forces and Moments

Location (m)	P _u (tonf)	M _{u33} (tonf-m)	M _{u22} (tonf-m)	V _{u2} (tonf)	V _{u3} (tonf)	T _u (tonf-m)
8.8	0	-38.5	0	23.49	0	0

Axial Force & Biaxial Moment Design Factors (H1-1b)

	L Factor	K ₁	K ₂	B ₁	B ₂	C _m
Major Bending	0.956	1	1	1	1	1
Minor Bending	0.333	1	1	1	1	1

Parameters for Lateral Torsion Buckling

L _{ltb}	K _{ltb}	C _b
0.333	1	1.014

Demand/Capacity (D/C) Ratio Eqn. (H1-1b)

D/C Ratio	$(P_r / 2P_c) + (M_{r33} / M_{c33}) + (M_{r22} / M_{c22})$
=	
0.475 =	0 + 0.475 + 0

Axial Force and Capacities

P _u Force (tonf)	φP _{nc} Capacity (tonf)	φP _{nt} Capacity (tonf)
0	415.68	503.05

Moments and Capacities

	M_u Moment (tonf-m)	φM_n Capacity (tonf-m)	φM_n No LTBD (tonf-m)
Major Bending	38.5	81.06	81.06
Minor Bending	0	27.62	

Shear Design

	V_u Force (tonf)	φV_n Capacity (tonf)	Stress Ratio
Major Shear	23.49	90.49	0.26
Minor Shear	0	216.4	0

End Reaction Major Shear Forces

Left End Reaction (tonf)	Load Combo	Right End Reaction (tonf)	Load Combo
23.49	DStlS2	23.49	DStlS2

DEFLECTION DESIGN (Combo DStlD2)

Type	Consider	Deflection m	Limit m	Ratio	Status
Dead Load	Yes	0.00692	0.075	0.092	OK
Super DL + Live Load	Yes	0.00816	0.075	0.109	OK
Live Load	Yes	0.00816	0.025	0.327	OK
Total Load	Yes	0.01509	0.0375	0.402	OK
Total - Camber	Yes	0.01509	0.0375	0.402	OK

3.4.3 Dome beam design (3BD):

- Properties:

Table 20 Steel section properties (IPE 450)

Section Property (IPE 450)								
A_g	0.00988	m^2	S_x	0.0015	m^3	C_w	0.00000039	m^6
b	0.19	m	S_y	0.000176	m^3	J	0.000001	m^4
d	0.379	m	r_x	0.185	m	L	6	m
h_o	0.394	m	r_y	0.0412	m	\emptyset_b	0.9	-
h	0.45	m	t_w	0.0094	m	\emptyset_v	1	-
I_x	0.0003374	m^4	t_f	0.0146	m	K_v	5	-
I_y	0.00001676	m^4	F_y	35153.48	t/m^2	C_b	1.195	-
Z_x	0.001702	m^3	F_u	45700	t/m^2	C_v	0.43	-
Z_y	0.000276	m^3	E	20389019.16	t/m^2	C	1	-
	Steel Section			ETABS Software			Building Code	

Note:

The data that are shown in blue are taken from the steel section properties, European Specifications Beams (EURONORM).

The data that are shown in green are taken from the ETABS software during the modeling phase.

The data that are shown in red are taken from the American Building Code according to its equations.

- **Moment design:**

1- Lateral-Torsional Bukling	
$L_b = L - [(0.211 \times L) \times 2]$ $L_b = 6 - [(0.211 \times 6) \times 2] = \mathbf{3.47 \text{ m}}$	
$L_p = 1.76 \times r_y \times \sqrt{\frac{E}{F_y}}$ $L_p = 1.76 \times 0.0412 \times \sqrt{\frac{20389019}{35153.48}} = \mathbf{1.75 \text{ m}}$	
$L_r = 1.95 \times r_{ts} \times \frac{E}{0.7 \times F_y} \times \sqrt{\frac{J \times c}{S_x \times h_o} + \sqrt{\left(\frac{J \times c}{S_x \times h_o}\right)^2 + 6.76 \left(\frac{0.7 \times F_y}{E}\right)^2}}$ $L_r = 1.95 \times 0.041 \times \frac{20389019.16}{0.7 \times 35153.48} \times \sqrt{\frac{1E-06 \times 1}{0.0015 \times 0.4} + \sqrt{\left(\frac{1E-06 \times 1}{0.0015 \times 0.394}\right)^2 + 6.76 \left(\frac{0.7 \times 35153.48}{20389019.16}\right)^2}} = \mathbf{4.84 \text{ m}}$	
$r_{ts} = \sqrt{\frac{\sqrt{I_y C_w}}{S_x}}$ $r_{ts} = \sqrt{\frac{\sqrt{1.7E-05 \times 0.00000039}}{0.0015}} = \mathbf{0.041 \text{ m}}$	

2- The Case for Lateral-Torsional Bukling						
a) $L_b \leq L_p$	$\mathbf{3.47 \text{ m}}$	\leq	$\mathbf{1.75 \text{ m}}$		$\mathbf{\times}$	
b) $L_p < L_b \leq L_r$	$\mathbf{1.75 \text{ m}}$	$<$	$\mathbf{3.47 \text{ m}}$	\leq	$\mathbf{4.84 \text{ m}}$	$\mathbf{\checkmark}$
c) $L_b > L_r$	$\mathbf{3.47 \text{ m}}$	$>$	$\mathbf{4.84 \text{ m}}$		$\mathbf{\times}$	

3- Nominal Moment

$$M_p = F_y \times Z_x = 35153.48 \times 0.0017 = 59.83 \text{ t/m}$$

$$M_n \leq M_p$$

$$M_n = C_b \left[M_p - (M_p - 0.7F_y S_x) \left(\frac{L_b - L_p}{L_r - L_p} \right) \right]$$

$$M_n = 1.20 \times \left[59.83 - (59.83 - 0.7 \times 35153.48 \times 0.0015) \left(\frac{3.47 - 1.75}{4.84 - 1.75} \right) \right] = 56.24 \text{ t/m}$$

$$\begin{array}{ccc} M_n & \leq & M_p \\ 56.24 & \leq & 59.83 \end{array} \quad \checkmark$$

4- Check for the Moment

$$M_u = 26.0 \text{ t/m}$$

$$M_u \leq \phi_b M_n$$

$$\phi_b M_n = 50.62 \text{ t/m}$$

$$\begin{array}{ccc} M_u & \leq & \phi_b M_n \\ 26.0 \text{ t/m} & \leq & 50.62 \text{ t/m} \end{array} \quad \checkmark$$

- Shear design:

1- Check for Web Shear Conditions (C_v)

$$\frac{h}{t_w} = \frac{0.45}{0.0094} = 47.87$$

$$1.37 \times \sqrt{\frac{k_v \times E}{F_y}}$$

$$1.37 \times \sqrt{\frac{5 \times 20389019.16}{35153.48}} = 73.78$$

$$\frac{h}{t_w} > 1.37 \sqrt{\frac{k_v \times E}{F_y}}$$

47.87
 $>$
 73.78
✓

2- Find the Value of Web Shear According to the Conditions (C_v)

$$C_v = \frac{1.51 \times E \times K_v}{\left(\frac{h}{t_w}\right)^2 \times F_y} =$$

$$C_v = \frac{1.51 \times 20389019.16 \times 5}{\left(\frac{0.45}{0.0094}\right)^2 \times 35153.48} = 1.91$$

3- Find Web Area (A_w)

$$A_w = d \times t_w = 0.379 \times 0.0094 = 0.00356 \text{ m}^2$$

4- Find Nominal Shear (V_n)

$$V_n = 0.6 \times F_y \times A_w \times \left(C_v + \frac{1 - C_v}{1.15 \times \sqrt{1 + \left(\frac{a}{h}\right)^2}} \right) =$$

$$V_n = 0.6 \times 35153.48 \times 0.00356 \times \left(0.43 + \frac{0.57}{1.15 \times \sqrt{1 + \left(\frac{0}{0.45}\right)^2}} \right) = 69.56 \text{ t}$$

5- Check for Shear

$$\phi_v \times V_n = 1 \times 69.56 = 69.56 \text{ t}$$

$$V_u \leq \phi_v V_n$$
$$20.88 \text{ t} \leq 69.56 \text{ t}$$



- **Deflection Check:**

Check for Deflection (Δ)	
$\Delta_{\max} = \frac{L}{240} = \frac{6000}{240} = 25 \text{ mm}$	
$\Delta_{\text{act}} = \frac{W_u \times L^4}{384 \times E \times I_x} + \frac{P \times L^3}{192 \times E \times I_x}$	
$\Delta_{\text{act}} = \frac{3.54 \times 6^4}{384 \times 20389019.16 \times 0.0002313} + \frac{20.52 \times 6^3}{192 \times 20389019.16 \times 0.0002313} = 7.4 \text{ mm}$	
$\Delta_{\text{act}} < \Delta_{\max}$ 7.4 mm < 25 mm	✓

Accordingly, the selected steel section for the dome beam is IPE 450. This section is safe against moment, shear, and deflection limit.

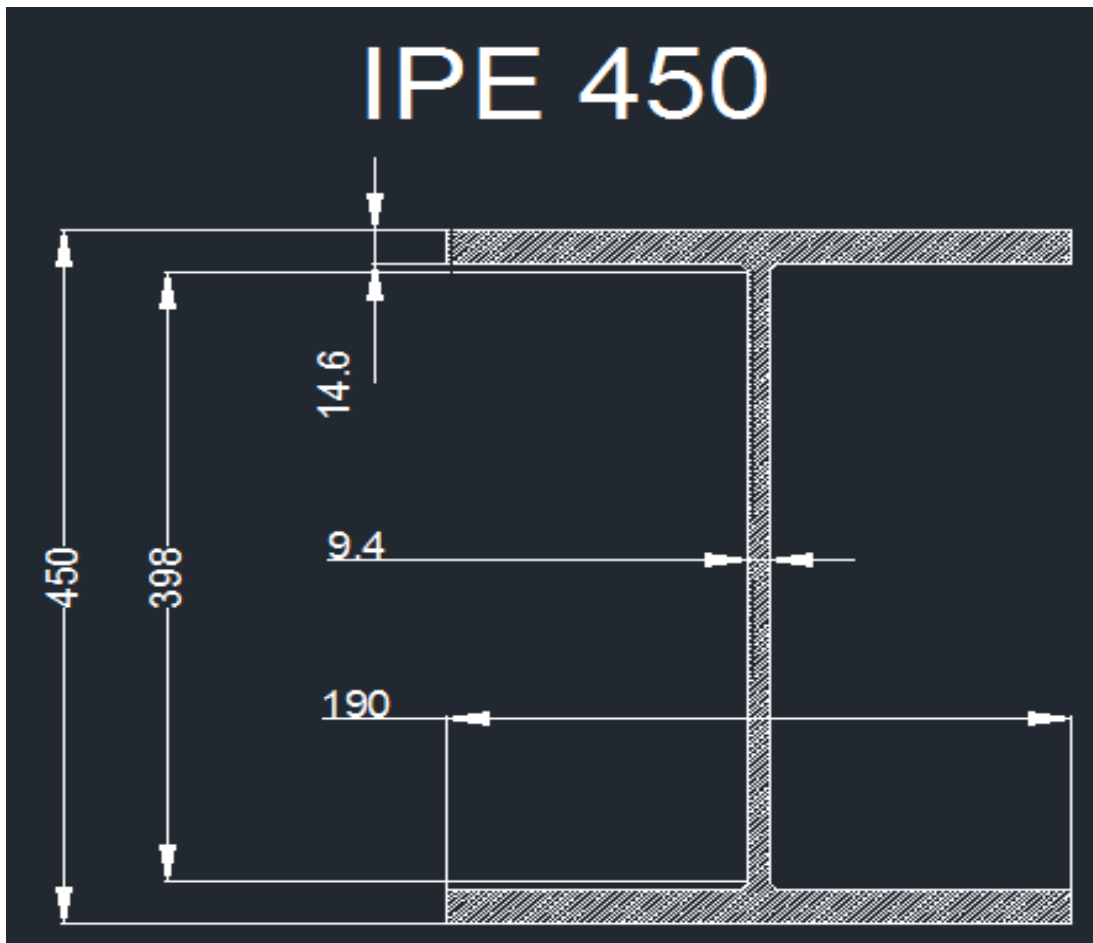

Figure 47 Steel section properties (IPE 450)

ETABS 2015 Steel Frame Design

(Dome beam)

AISC 360-10 Steel Section Check (Strength Summary)

Element Details

Level	Element	Location (m)	Combo	Element Type	Section	Classification
Mezzanine	B39	3	DStlS2	Special Moment Frame	IPE450	Compact

LLRF and Demand/Capacity Ratio

L (m)	LLRF	Stress Ratio Limit
6.00000	1	0.95

Analysis and Design Parameters

Provision	Analysis	2nd Order	Reduction
LRFD	Direct Analysis	General 2nd Order	Tau-b Fixed

Stiffness Reduction Factors

$\alpha P_r / P_y$	$\alpha P_r / P_e$	τ_b	EA factor	EI factor
0	0	1	0.8	0.8

Design Code Parameters

Φ_b	Φ_c	Φ_{TY}	Φ_{TF}	Φ_V	Φ_{V-RI}	Φ_{VT}
0.9	0.9	0.9	0.75	0.9	1	1

Section Properties

A (m ²)	J (m ⁴)	I ₃₃ (m ⁴)	I ₂₂ (m ⁴)	A _{v3} (m ²)	A _{v2} (m ²)
0.0099	0.00000 1	0.000337	0.000017	0.0055	0.0042

Design Properties

S₃₃ (m³)	S₂₂ (m³)	Z₃₃ (m³)	Z₂₂ (m³)	r₃₃ (m)	r₂₂ (m)	C_w (m⁶)
0.0015	0.000176	0.001702	0.000276	0.1848	0.04119	0

Material Properties

E (tonf/m²)	f_y (tonf/m²)	R_y	α
20389019.16	35153.48	1.1	NA

Stress Check forces and Moments

Location (m)	P_u (tonf)	M_{u33} (tonf-m)	M_{u22} (tonf-m)	V_{u2} (tonf)	V_{u3} (tonf)	T_u (tonf-m)
3	0	22.18	0	0	0	1.497E-03

Axial Force & Biaxial Moment Design Factors (H1.3b, H1-2)

	L Factor	K₁	K₂	B₁	B₂	C_m
Major Bending	1	1	1	1	1	1
Minor Bending	1	1	1	1	1	1

Parameters for Lateral Torsion Buckling

L_{ltb}	K_{ltb}	C_b
1	1	1.136

Demand/Capacity (D/C) Ratio Eqn. (H1.3b, H1-2)

D/C Ratio	(P_r /P_c) + (M_{r33} /M_{c33})² +(M_{r22} /M_{c22})
=	
0.521 =	0 + 0.521 + 0

Axial Force and Capacities

P_u Force (tonf)	φP_{nc} Capacity (tonf)	φP_{nt} Capacity (tonf)
0	73.95	312.58

Moments and Capacities

	M_u Moment (tonf-m)	φM_n Capacity (tonf-m)	φM_n No LTBD (tonf-m)
Major Bending	22.18	30.74	53.85
Minor Bending	0	8.73	

Shear Design

	V_u Force (tonf)	φV_n Capacity (tonf)	Stress Ratio
Major Shear	0	89.22	0
Minor Shear	0	105.32	0

End Reaction Major Shear Forces

Left End Reaction (tonf)	Load Combo	Right End Reaction (tonf)	Load Combo
14.79	DStlS2	14.79	DStlS2

DEFLECTION DESIGN (Combo DStlD2)

Type	Consider	Deflection m	Limit m	Ratio	Status
Dead Load	Yes	0.00514	0.05	0.103	OK
Super DL + Live Load	Yes	0.00366	0.05	0.073	OK
Live Load	Yes	0.00366	0.01667	0.22	OK
Total Load	Yes	0.0088	0.025	0.352	OK
Total - Camber	Yes	0.0088	0.025	0.352	OK

3.4.4 Column design (2C):

- Properties:

Table 21 Steel section properties (HE 400 B)

Section Property (HE400B)								
A_g	0.0198	m^2	S_x	0.002884	m^3	C_w	0.000000022	m^6
b	0.3	m	S_y	0.000721	m^3	J	0.000002	m^4
d	0.298	m	r_x	0.171	m	L	7	m
h_o	0.32	m	r_y	0.074	m	ϕ_b	0.9	-
h	0.39	m	t_w	0.0135	m	ϕ_v	1	-
I_x	0.0005768	m^4	t_f	0.024	m	K_v	5	-
I_y	0.00001082	m^4	F_y	35153.48	t/m^2	C_b	1.14	-
Z_x	0.003232	m^3	F_u	45700	t/m^2	K	0.65	-
Z_y	0.001104	m^3	E	20389019.16	t/m^2	C	1	-
	Steel Section			Etabs Software			Building Code	

Note:

The data that are shown in blue are taken from the steel section properties, European Specifications Beams (EURONORM).

The data that are shown in green are taken from the ETABS 2015 software during the modeling phase.

The data that are shown in red are taken from the American Building Code according to its equations.

- **Moment design:**

1- Lateral-Torsional Bukiing	
$L_b = L - [(0.211 \times L) \times 2]$ $L_b = 7 - [(0.211 \times 7) \times 2] = 4.05 \text{ m}$	
$L_p = 1.76 \times r_y \times \sqrt{\frac{E}{F_y}}$ $L_p = 1.76 \times 0.074 \times \sqrt{\frac{20389019}{35153.48}} = 3.14 \text{ m}$	
$L_r = 1.95 \times r_{ts} \times \frac{E}{0.7 \times F_y} \times \sqrt{\frac{J \times c}{S_x \times h_o} + \sqrt{\left(\frac{J \times c}{S_x \times h_o}\right)^2 + 6.76 \left(\frac{0.7 \times F_y}{E}\right)^2}}$ $L_r = 1.95 \times 0 \times \frac{20389019.16}{0.7 \times 35153.48} \times \sqrt{\frac{0.000002 \times 1}{0.002884 \times 0.3} + \sqrt{\left(\frac{0.000002 \times 1}{0.002884 \times 0.32}\right)^2 + 6.76 \left(\frac{0.7 \times 35153.48}{20389019.16}\right)^2}} = 1.63 \text{ m}$	
$r_{ts} = \sqrt{\frac{I_y C_w}{S_x}}$ $r_{ts} = \sqrt{\frac{1.082E-05 \times 0.000000022}{0.002884}} = 0.01 \text{ m}$	

2- The Case for Lateral-Torsional Bukiing						
a) $L_b \leq L_p$	4.05 m	\leq	3.14 m		✘	
b) $L_p < L_b \leq L_r$	3.14 m	$<$	4.05 m	\leq	1.63 m	✘
c) $L_b > L_r$	4.05 m	$>$	1.63 m		✔	

3- Find Buckling Stress

$$F_{cr} = \frac{C_b \pi^2 E}{\left(\frac{L_b}{r_{ts}}\right)^2} \times \sqrt{1 + 0.078 \times \frac{Jc}{S_x h_o} \times \left(\frac{L_b}{r_{ts}}\right)^2}$$

$$F_{cr} = \frac{1.14 \times 3.142^2 \times 20389019.16}{\left(\frac{4.05}{0.01}\right)^2} \times \sqrt{1 + 0.078 \times \frac{0.000002 \times 1}{0.002884 \times 0.32} \times \left(\frac{4.05}{0.01}\right)^2} = 9876.82 \quad \text{t/m}^2$$

4- Nominal Moment

$$M_p = F_y \times Z_x = 35153.48 \times 0.00323 = 113.62 \quad \text{t/m}$$

$$M_n = F_{cr} \times S_x = 9876.82 \times 0.00288 = 28.48 \text{ t/m}$$

5- Check for the Moment

$$\phi_b \times M_n \leq M_p$$

$$\begin{array}{lcl} \phi_b \times M_n & \leq & M_p \\ 0.9 \times 37.90 & \leq & 113.62 \\ 25.64 & \leq & 113.62 \end{array}$$



Compression buckling design is required for the column to know the bearing capacity of column.

1- Cases for Flexural Buckling Stress

$$1) \frac{KL}{r_x} \leq 4.71 \times \sqrt{\frac{E}{F_y}}$$

$$2) \frac{KL}{r_x} > 4.71 \times \sqrt{\frac{E}{F_y}}$$

2- Caculate Buckling Stress

$$\frac{KL}{r_x} = \frac{0.65 \times 7}{0.171} = 26.61$$

$$4.71 \times \sqrt{\frac{E}{F_y}}$$

$$4.71 \times \sqrt{\frac{20389019.16}{35153.48}} = 113.43$$

3- Check for Buckling Stress

$$\frac{KL}{r_x} \leq 4.71 \times \sqrt{\frac{E}{F_y}}$$

$$26.61 \leq 113.43$$

So It's the first case

4- Elastic Critical Buckling Stress

$$F_e = \frac{\pi^2 \times E}{\left(\frac{KL}{r_x}\right)^2} = \frac{(3.142)^2 \times 20389019.16}{\left(\frac{0.65 \times 7}{0.171}\right)^2} = 284228 \text{ t/m}^2$$

5- Buckling Stress

$$F_{cr} = \left[0.658 \frac{F_y}{F_e} \right] \times F_y =$$

$$F_{cr} = \left[0.658 \frac{35153.48}{284228.44} \right] \times 35153.48 = 33380.01 \text{ t/m}^2$$

6- Nominal Compressive Strength

$$P_n = F_{cr} \times A_g = 33380.01 \times 0.0198 = 660.92 \text{ t}$$

$$V_{\max} \leq P_n$$

230.23 ≤ 660.92 ✓

- Deflection:

Check for Deflection (Δ)			
$\Delta_{\max} = \frac{L}{240} = \frac{7}{240} =$		29.17 mm	
$\Delta_{\text{act}} = \frac{W_u \times L^4}{384 \times E \times I_x} = \frac{32.89 \times 7^4}{384 \times 20389019.16 \times 0.000451} =$		22.38 mm	
$\Delta_{\text{act}} < \Delta_{\max}$		$22.38 \text{ mm} < 29.17 \text{ mm}$	✓

Accordingly, the selected steel section for the roof beam is HE 400 B. This section is safe against moment, shear, and deflection limit.

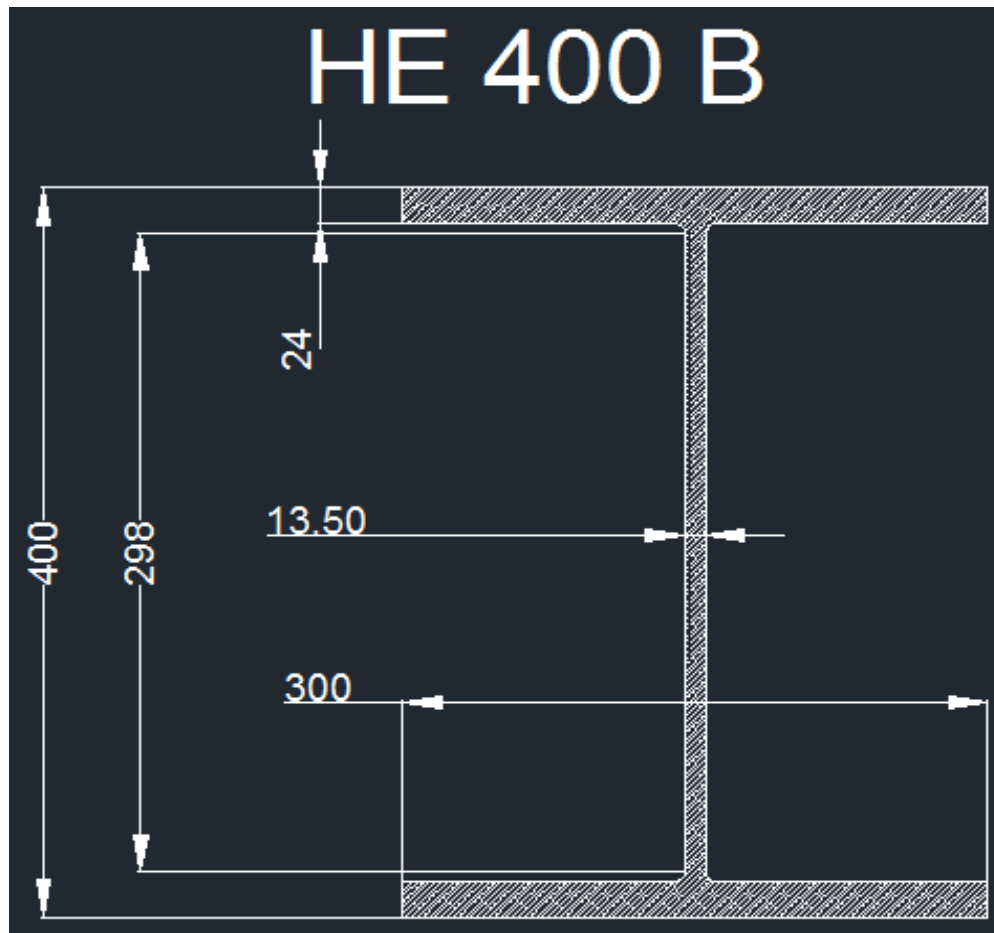

Figure 48 Steel section properties (HE 400 B)

ETABS 2015 Steel Frame Design

(Column)

AISC 360-10 Steel Section Check (Strength Summary)

Element Details

Level	Element	Location (m)	Combo	Element Type	Section	Classification
Mezzanine	C28	6.5	DStlS2	Special Moment Frame	HE400B	Compact

LLRF and Demand/Capacity Ratio

L (m)	LLRF	Stress Ratio Limit
7.00000	1	0.95

Analysis and Design Parameters

Provision	Analysis	2nd Order	Reduction
LRFD	Direct Analysis	General 2nd Order	Tau-b Fixed

Stiffness Reduction Factors

$\alpha P_r / P_y$	$\alpha P_r / P_e$	τ_b	EA factor	EI factor
0	0	1	0.8	0.8

Design Code Parameters

Φ_b	Φ_c	Φ_{TY}	Φ_{TF}	Φ_V	Φ_{V-RI}	Φ_{VT}
0.9	0.9	0.9	0.75	0.9	1	1

Section Properties

A (m²)	J (m⁴)	I₃₃ (m⁴)	I₂₂ (m⁴)	A_{v3} (m²)	A_{v2} (m²)
0.0198	0.000004	0.000577	0.000108	0.0144	0.0054

Design Properties

S₃₃ (m³)	S₂₂ (m³)	Z₃₃ (m³)	Z₂₂ (m³)	r₃₃ (m)	r₂₂ (m)	C_w (m⁶)
0.002884	0.000721	0.003232	0.001104	0.17068	0.07392	0

Material Properties

E (tonf/m²)	f_y (tonf/m²)	R_y	α
20389019.16	35153.48	1.1	NA

Stress Check forces and Moments

Location (m)	P_u (tonf)	M_{u33} (tonf-m)	M_{u22} (tonf-m)	V_{u2} (tonf)	V_{u3} (tonf)	T_u (tonf-m)
6.5	0	0	0	0	0	0

Axial Force & Biaxial Moment Design Factors (H1-1b)

	L Factor	K₁	K₂	B₁	B₂	C_m
Major Bending	0.929	1	1	1	1	1
Minor Bending	0.929	1	1	1	1	1

Parameters for Lateral Torsion Buckling

L_{ltb}	K_{ltb}	C_b
0.929	1	1

Demand/Capacity (D/C) Ratio Eqn. (H1-1b)

D/C Ratio	$(P_r / 2P_c) + (M_{r33} / M_{c33}) + (M_{r22} / M_{c22})$
=	
0 =	0 + 0 + 0

Axial Force and Capacities

P_u Force (tonf)	φP_{nc} Capacity (tonf)	φP_{nt} Capacity (tonf)
0	355.93	626.44

Moments and Capacities

	M_u Moment (tonf-m)	φM_n Capacity (tonf-m)	φM_n No LTBD (tonf-m)
Major Bending	0	87.78	102.25
Minor Bending	0	34.93	

Shear Design

	V_u Force (tonf)	φV_n Capacity (tonf)	Stress Ratio
Major Shear	0	113.9	0
Minor Shear	0	273.35	0

Joint Design

Continuity Plate Area (m²)	Load Combo	Doubler (m)	Load Combo
0.0026	DStlS2	0.01476	DStlS2

3.4.5 ETABS drawings:

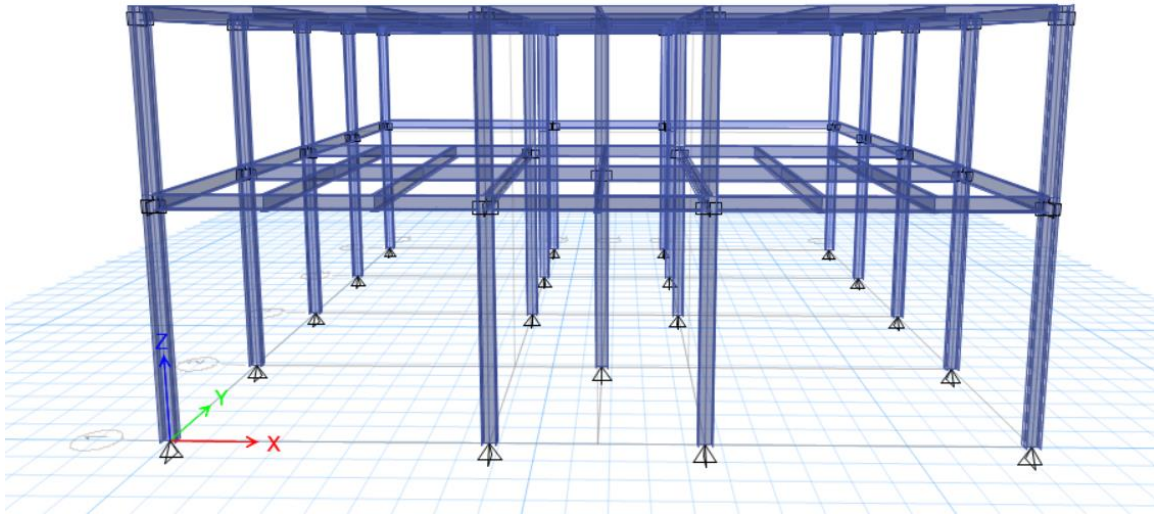

Figure 49 ETABS 3D model

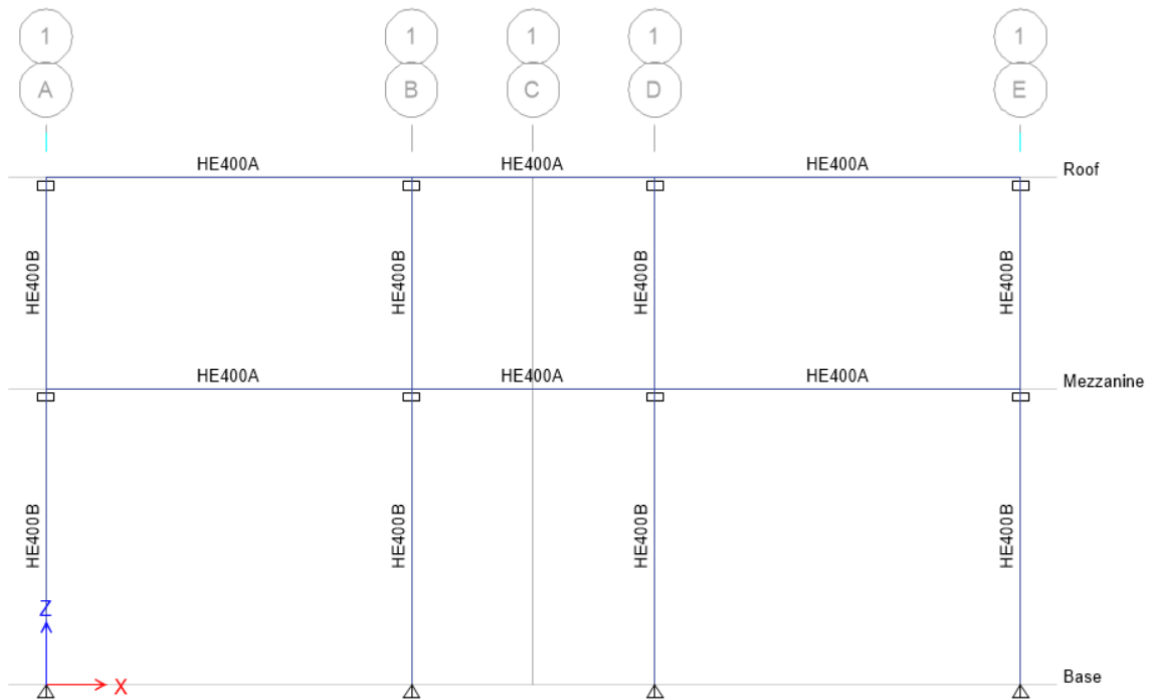

Figure 50 Side view

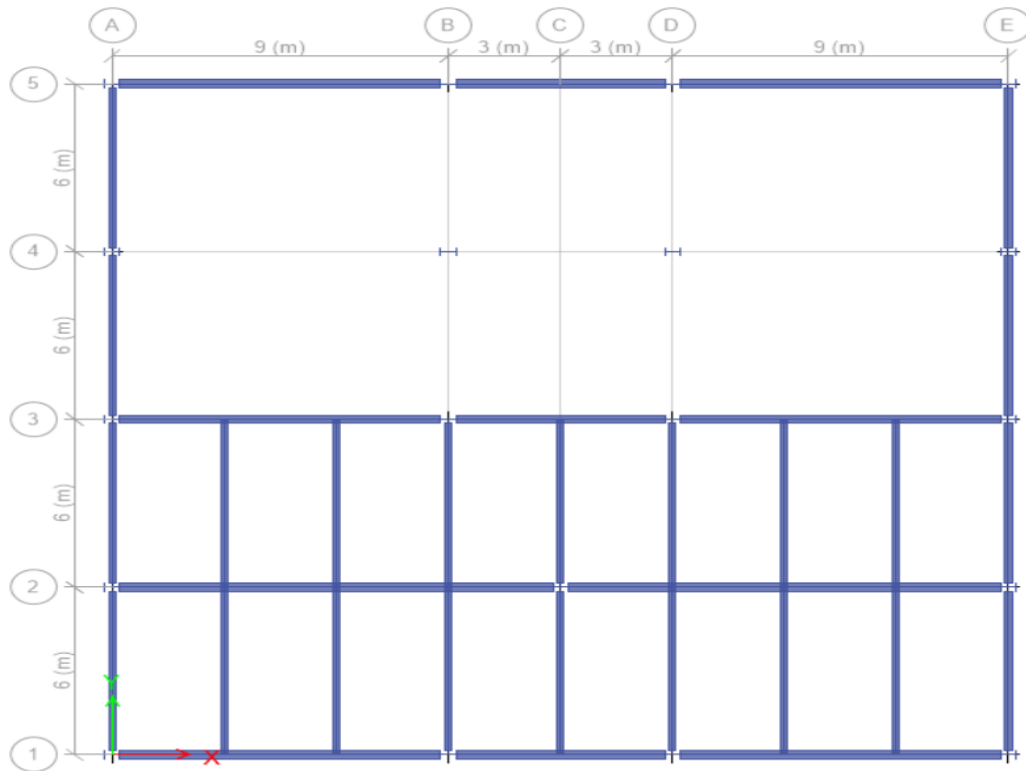

Figure 51 Top view for mezzanine floor

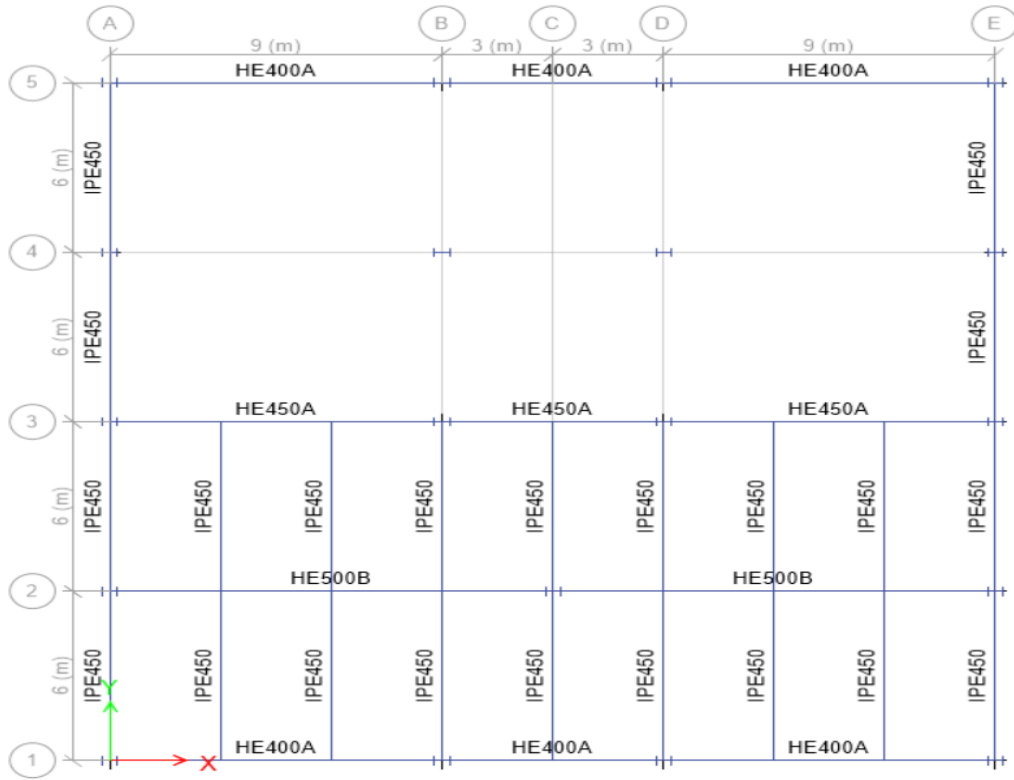

Figure 52 Top view of sections for mezzanine floor

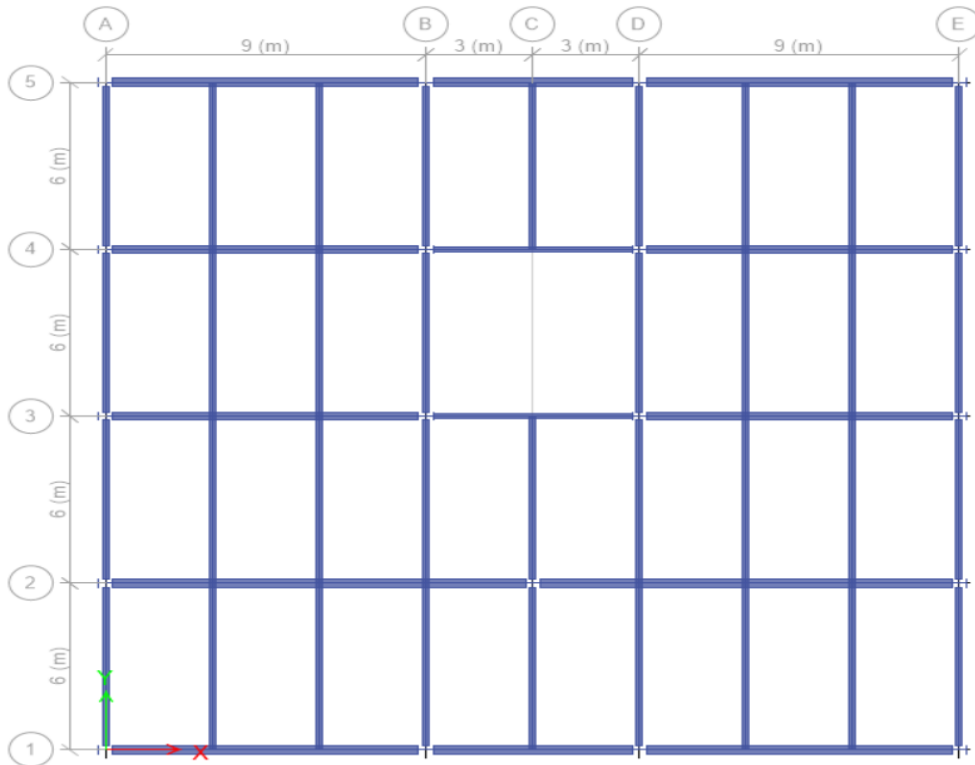

Figure 53 Top view for roof

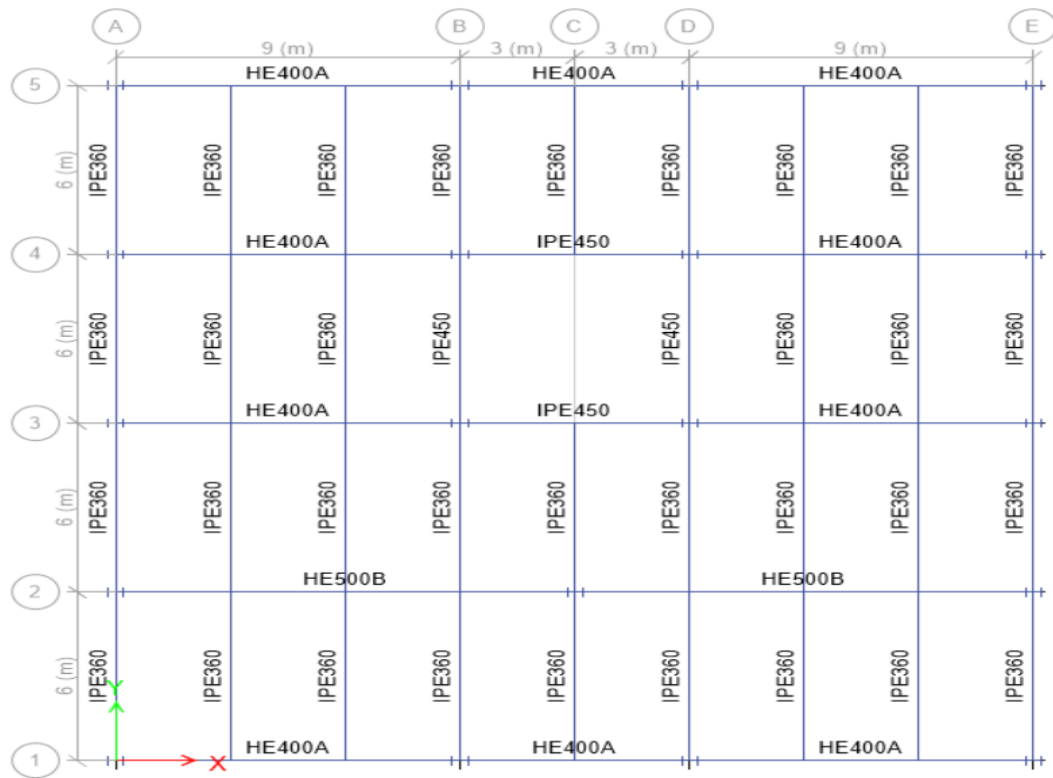

Figure 54 Top view of sections for roof

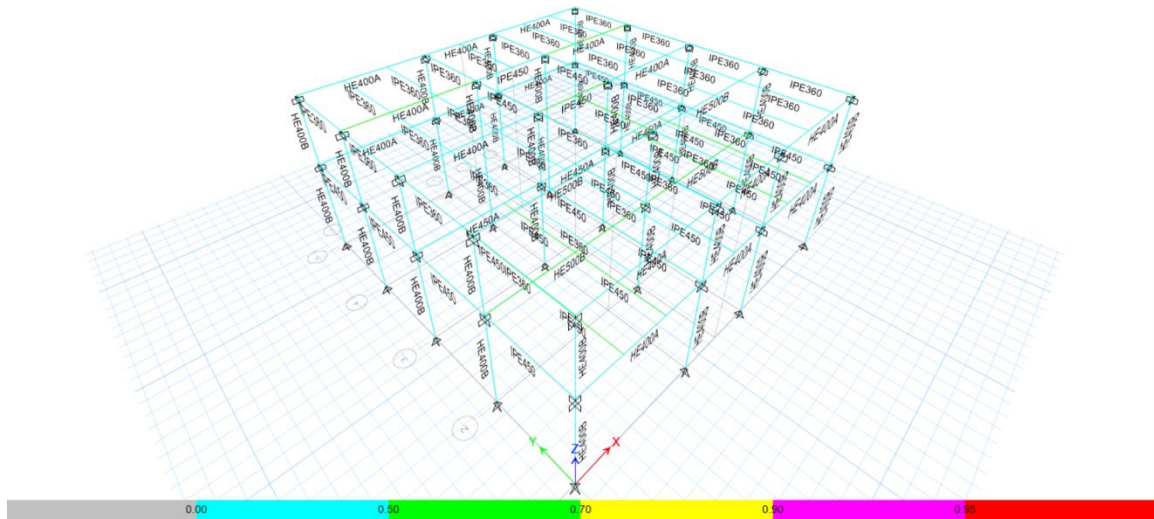

Figure 55 Steel stress ratio (column)

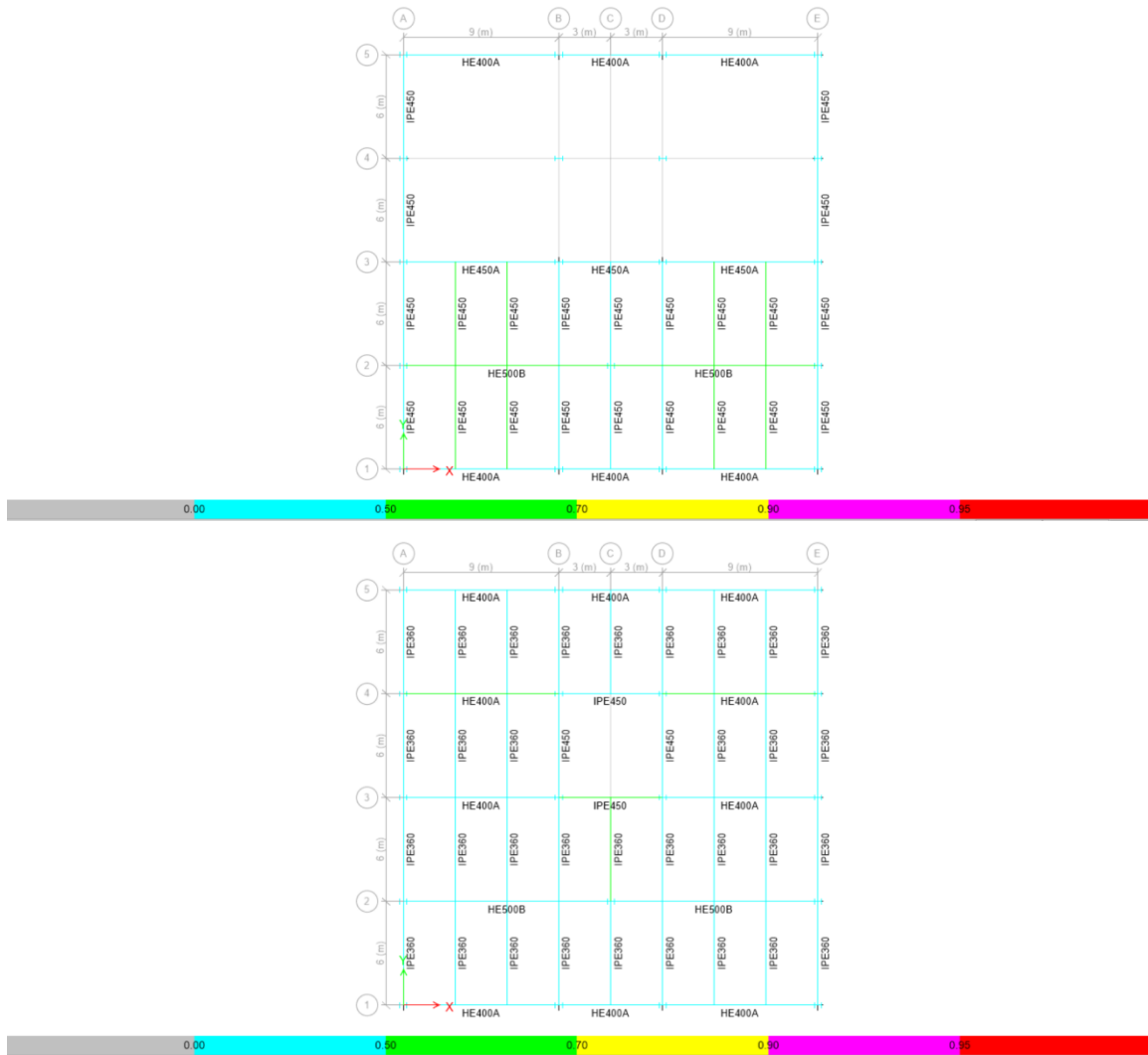

Figure 56 Steel stress ratio (mezzanine and roof)

3.5 Connection design:

Steel moment frames have been in use for more than one hundred years, dating to the earliest use of structural steel in building construction. Steel building construction with the frame carrying the vertical loads initiated with the Home Insurance Building in Chicago, a 10 story structure constructed in 1884 with a height of 45 meter often credited with being the first skyscraper.

This and other tall buildings in Chicago spawned an entire generation of tall buildings, constructed with load bearing steel frames supporting concrete floors and non-load bearing, unreinforced masonry infill walls at their perimeters. Framing in these early structures typically utilized "H" shapes built up from plates, and "L" and "Z" sections.

Moment-resisting frames are rectilinear assemblages of beams and columns, with the beams rigidly connected to the columns. Resistance to lateral forces is provided primarily by rigid frame action, by the development of bending moment and shear force in the frame members and joints.

Through virtue of the rigid beam-column connections, a moment frame cannot displace laterally without bending the beams or columns depending on the geometry of the connection. The bending rigidity and strength of the frame members is therefore the primary source of lateral stiffness and strength for the entire frame.

Two combined connection type will be used in this design section, Bolted connection and Welded connection. In this section, connection design for the steel structure frame will be applied to calculate the needed numbers of the bolts and weld length. American Institute of Steel Construction (AISC) Manual of Steel Construction/ Allowable Strength Design (ASD) is applied. In addition to calculations, LimCon software will be used for connection design. LimCon output will be included with the appendix.

3.5.1 Connection of Mezzanine Floor:

3.5.1.1 Moment Connection (column HEB 400 with beam HEB500):

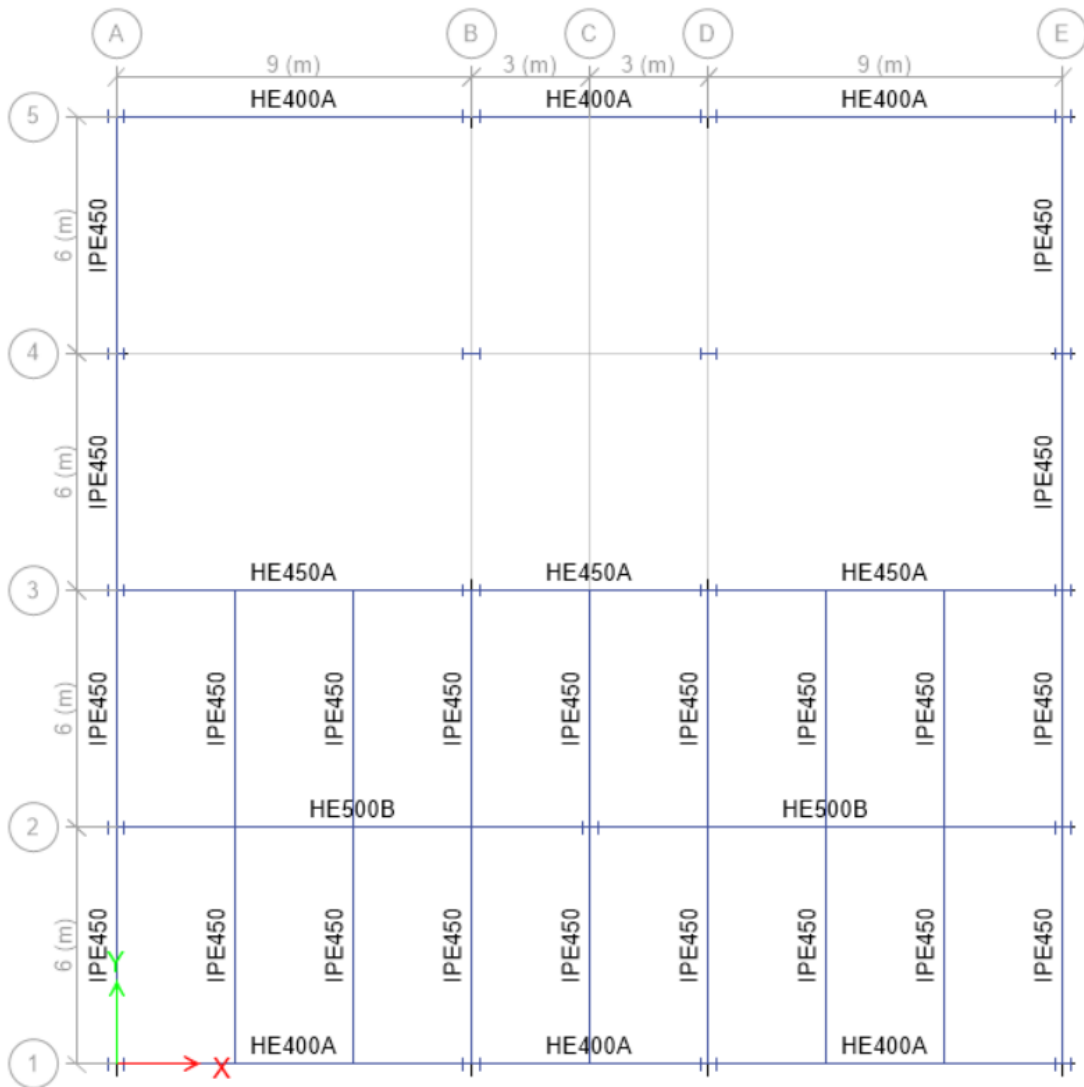

Figure 57 Mezzanine Floor plan - Connection

Material specification:

Material: steel grade (36)		
F_y	3.6	t/cm ²
F_u	5.2	t/cm ²

Bolts		
D	30	mm
Grade	10.9	-
A_s	5.61	cm ²
T	35.34	t
P_s	16.86	t

Section properties:

Column Section (HEB400)		
h	400	mm
h _i	352	mm
b _f	300	mm
t _w	13.5	mm
t _f	24	mm
r	27	mm
A	198	cm ²
I _x	57680	cm ⁴

Beam Section (HEB500)		
h	500	mm
h _i	444	mm
b _f	300	mm
t _w	14.5	mm
t _f	28	mm
r	27	mm
A	239	cm ²
I _x	107200	cm ⁴

Loading:

Analysis of Moment and Shear (ASD Method)			
Dead Load =	4.078	t-m	
Live Load =	3	t-m	
Ultimated Load =	DL	+	LL
	4.08	+	3 = 7.078 t-m

Calculating for Moment and Shear	
$M_{\max} = \frac{W_u \times L^2}{12} = \frac{7.078 \times 12^2}{12} = 84.94 \text{ t-m}$	
$V_{\max} = \frac{W_u \times L}{2} = \frac{7.078 \times 12}{2} = 42.47 \text{ t}$	

Combined Connection Bolts and Welds	
$M_{b \text{ and } w} = \frac{M_{\max}}{2} = \frac{84.94}{2} = 42.47 \text{ t-m}$	
$V_{b \text{ and } w} = \frac{V_{\max}}{2} = \frac{42.47}{2} = 21.23 \text{ t}$	

Design of welding:

1- Length of weld lines around the flange for Beam

$$L_f = b_f + (b_f - t_w - 2 \times t_f) =$$

$$L_f = 30 + (30 - 1.45 - 2 \times 2.8) = 52.95 \text{ cm}$$

2 -Welding size around the flange

$$T_b = \frac{M_{\max(\text{ASD})}}{h - t_f} = \frac{42.47 \times 100}{50 - 2.8} = 89.97 \text{ t}$$

3 -The Stress of Welding

$$F_{pw} = 0.2 \times F_u =$$

$$F_{pw} = 0.2 \times 5.2 = 1.04 \text{ t/cm}^2$$

4 -The Thickness of welding around the Flange

$$S_w = \frac{T_b}{L_f \times F_{pw}} = \frac{89.97}{52.95 \times 1.04} = 1.63 \text{ cm}$$

Take $S_w = 2 \text{ cm}$

5 - Length of weld lines around the Web of Beam

$$L_w = 2 \times (b_f - 2 \times t_f) =$$

$$L_w = 2 \times (30 - 2 \times 2.8) = 48.8 \text{ cm}$$

6 - The Thickness of welding around the Web

$$S_w = \frac{V_b}{L_w \times F_{pw}} = \frac{21.23}{48.8 \times 1.04} = 0.42 \text{ cm}$$

Take $S_w = 2 \text{ cm}$

The Total Thickness of Welding around Web and Flange

$S_w = 2 \text{ cm}$

Properties of new beam section:

$S_w = 20 \text{ mm}$

$$C = b_f/2 - S_w - (t_w/2) =$$

$$C = 300 / 2 - 20 - (14.5 / 2) = 122.75 \text{ mm}$$

$$d_w = h_i - (S_w \times 2) =$$

$$d_w = 444 - (20 \times 2) = 404 \text{ mm}$$

$$X_1 = d_w / 2 + S_w =$$

$$X_1 = 404 / 2 + 20 = 232 \text{ mm}$$

$$X_2 = X_1 + t_f =$$

$$X_2 = 232 + 28 = 260 \text{ mm}$$

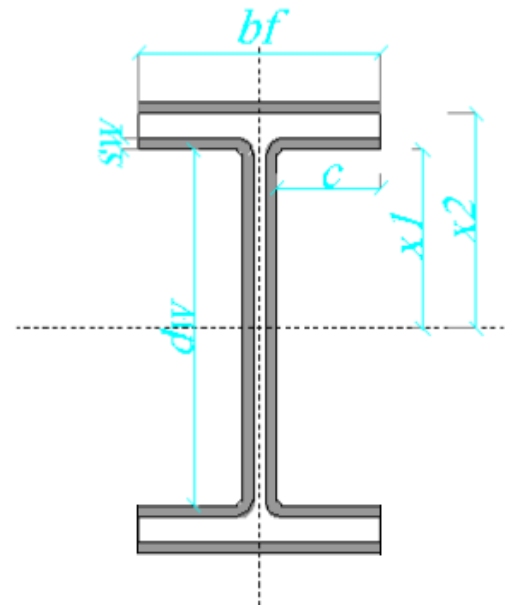

Checking the safety of welding:

1- Area of Welding

$$A_w = (2 \times d_w \times S_w) + (2 \times d_f \times S_w) + (4 \times C \times S_w) =$$

$$A_w = (2 \times 40 \times 2) + (2 \times 30 \times 2) + (4 \times 12.28 \times 2) = 379.8 \text{ cm}^2$$

2- Inertia Moment of Welding Section

$$I_{xw} = \left(\frac{d_w^3 \times S_w}{12} \times 2 \right) + \left(\frac{C \times S_w^3}{12} \times 4 \right) + (C \times S_w \times X_1^2 \times 4) + \left(\frac{b_f \times S_w^3}{12} \times 2 \right) + (b_f \times S_w \times X_2^2 \times 4) =$$

$$I_{xw} = \left(\frac{131879}{12} \times 2 \right) + \left(\frac{98.2}{12} \times 4 \right) + (12.28 \times 2 \times 538.2 \times 4) + \left(\frac{240}{12} \times 2 \right) + (30 \times 2 \times 6760 \times 4) = 1697307.66 \text{ cm}^4$$

3- Tensile Stress

$$F_t = \frac{M_{\max} \times y}{I_{xw}} = \frac{8494 \times 25}{1697307.66} = 0.12510 \text{ t/cm}^2$$

4- Gross Effective Area

$$q = \frac{V}{2 \times S_w \times d_w} = \frac{42.5}{2 \times 2 \times 40.4} = 0.263 \text{ t/cm}^2$$

5- Equivalent Stress

$$F_{eq} = \sqrt{F_t^2 + 3q^2} = \sqrt{0.12510^2 + 3 \times 0.263^2} = 0.332 \text{ t/cm}^2$$

6- Allowable Stress

$$F_{allw} = 1.1 \times F_{pw} = 1.1 \times 1 = 1.1 \text{ t/cm}^2$$

7- Check the safety of welding

$$F_{eq} < F_{allw}$$

$$0.332 < 1.14 \quad \checkmark$$

Design of Bolts:

1- Number of Bolts		
$T_b = \frac{M_{\max(\text{ASD})}}{h - t_f} = \frac{42.47 \times 100}{50 - 2.8} = 89.97 \text{ t}$		
$N_b = \frac{T_b}{T} = \frac{89.97}{35.34} = 2.55$		
The Number of Bolts in one Row =	5	Bolts
The Number of Bolts in Plate =	10	Bolts

2- Tensile Force		
$T_{\text{ext}_b} = \frac{T_b}{\text{Number of Tension bolt}} = \frac{42}{6} = 7.1 \text{ t}$		

3- Prying Force		
$P = \left[\frac{0.5 - \left[\frac{W \times T_b^4}{30 \times a \times b^2 \times A_s} \right]}{\left(\frac{3 \times a}{4 \times b} \right) \times \left(\frac{a}{4 \times b} + 1 \right) + \left[\frac{W \times T_b^4}{30 \times a \times b^2 \times A_s} \right]} \right] \times T_{\text{ext}_b} =$		
$P = \left[\frac{0.5 - \left[\frac{224}{13237.5} \right]}{\left(\frac{15}{20} \right) \times (0.25 + 1) + \left[\frac{224}{13237.5} \right]} \right] \times 7$		
$P = 2.41 \text{ t}$		

Checking the safety of bolts:

$$T_{ext_b} + P \leq 0.8 \times T$$

$$7.1 + 2.41 \leq 0.8 \times 35.34$$

$$9.48 \leq 28.27 \quad \text{O.K.}$$

Checking for shear:

$$V_b = \frac{V_{\max}}{n} = \frac{21.2}{10} = 2.1 \text{ t}$$

$$V_b < P_s$$

$$2.12 < 16.86 \quad \text{O.K.}$$

Design of end plates:

Allowable Stress in Bending

$$F_c = 0.64 \times F_y = 0.64 \times 3.60 = 2.3 \text{ t/cm}^2$$

Size around the flange

$$T_b = \frac{M_{\max(\text{ASD})}}{h - t_f} = \frac{84.94 \times 100}{50 - 2.8} = 60.7 \text{ t}$$

Moment

$$M = \frac{T_p \times L}{8} = \frac{60.7 \times 75}{8} = 569 \text{ t-cm}$$

Thickness of Plate

$$t_p = \sqrt{\frac{6 \times M}{2 \times w \times F_c}} = \sqrt{\frac{6 \times 569}{2 \times 15 \times 2.30}} = 7 \text{ cm}$$

Plate Size

Thickness of Plate =	7 cm
Length of Plate =	75 cm
Width of Plate =	28 cm

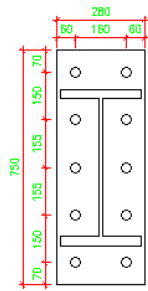
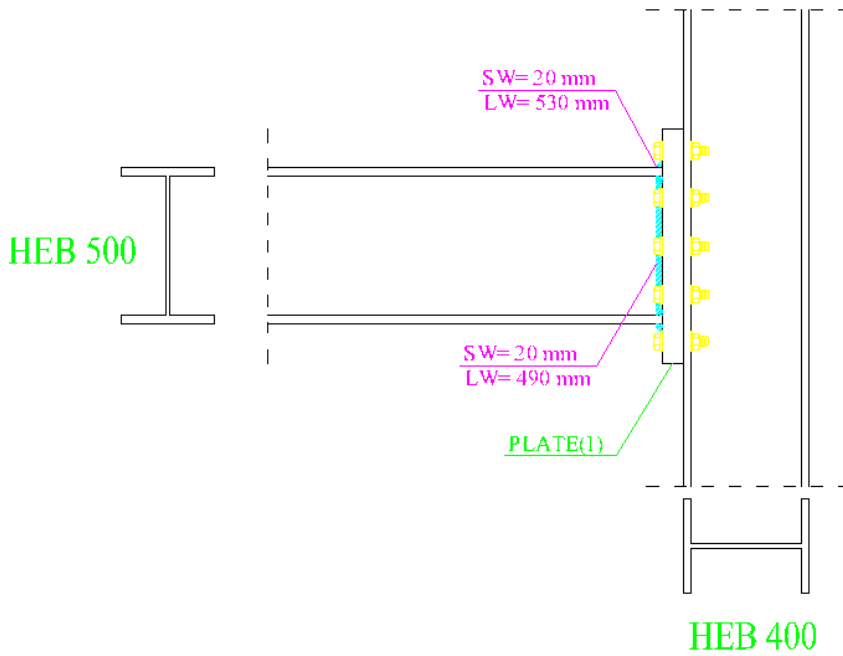
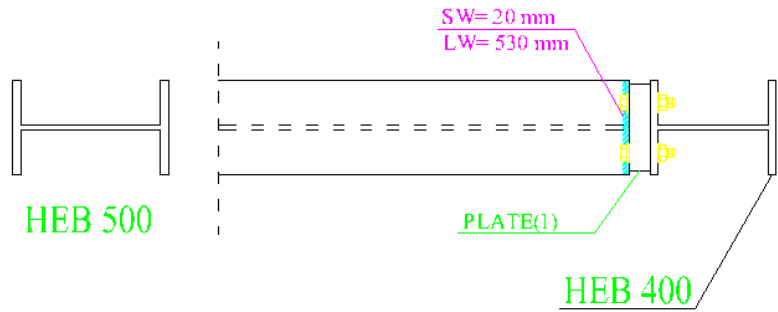

PLATE (1)
 PL 750 x 280 X70
 10M30 (10.9)
 HOLE DIAM 32mm



FRONT VIEW

AutoCad Connection Drawing for Moment Connection in Mezzanine Floor

3.5.1.2 Simple connection (beam HEA 400 with beam IPE 450):

Material specification:

Material: steel grade (36)		
F_y	3.6	t/cm ²
F_u	5.2	t/cm ²

Bolts		
D	30	mm
Grade	10.9	-
A_s	5.61	cm ²
T	35.34	t
P_s	14.13	t

Section properties:

Beam Section (IPE 450)			Beam Section (HEA 400)		
h	450	mm	h	390	mm
h_i	420.8	mm	h_i	352	mm
b_f	190	mm	b_f	300	mm
t_w	9.8	mm	t_w	11	mm
t_f	14.6	mm	t_f	24	mm
r	21	mm	r	27	mm
A	98.8	cm ²	A	195	cm ²
I_x	33740	cm ⁴	I_x	45070	cm ⁴

Loading:

Analysis of Moment and Shear (ASD Method)				
Dead Load =	4.078	t-m		
Live Load =	3	t-m		
Ultimated Load =		DL	+	LL
		2.11	+	1.5 = 3.610 t-m

Calculating for Moment and Shear				
$M_{\max} = \frac{W_u \times L^2}{12} = \frac{3.61 \times 12^2}{12} = 43.32$	t-m			
$V_{\max} = \frac{W_u \times L}{2} = \frac{3.61 \times 12}{2} = 21.66$	t			

Design of welding:

1- Length of weld lines around the flange for Beam

$$L_f = b_f + (b_f - t_w - 2 \times t_f) =$$
$$L_f = 19 + (19 - 0.98 - 2 \times 1.46) = 34.1 \text{ cm}$$

2 -Welding size around the flange

$$T_b = \frac{M_{\max(\text{ASD})}}{h - t_f} = \frac{43.32 \times 100}{45 - 1.46} = 99.49 \text{ t}$$

3 -The Stress of Welding

$$F_{pw} = 0.2 \times F_u =$$
$$F_{pw} = 0.2 \times 5.2 = 1.04 \text{ t/cm}^2$$

4 -The Thickness of welding around the Flange

$$S_w = \frac{T_b}{L_f \times F_{pw}} = \frac{99.49}{34.10 \times 1.04} = 2.81 \text{ cm}$$

$$\text{Take } S_w = 3 \text{ cm}$$

5 - Length of weld lines around the Web of Beam

$$L_w = 2 \times (b_f - 2 \times t_f) =$$
$$L_w = 2 \times (19 - 2 \times 1.46) = 32.2 \text{ cm}$$

6 - The Thickness of welding around the Web

$$S_w = \frac{V_b}{L_w \times F_{pw}} = \frac{21.66}{32.2 \times 1.04} = 0.65 \text{ cm}$$

Take $S_w = 1 \text{ cm}$

The Total Thickness of Welding around Web and Flange

$S_w = 3 \text{ cm}$

Design of bolts:

1- Prestressing for angle Plate Double Shear

$$T_d = \frac{T}{2} = \frac{35.34}{2} = 17.67 \text{ t}$$

2- Number of Bolts

$$T_b = \frac{M_{\max(\text{ASD})}}{h - t_f} = \frac{43.32 \times 100}{45 - 1.46} = 99.49 \text{ t}$$

$$N_b = \frac{T_b}{T_d} = \frac{99.49}{17.67} = 5.63$$

The Number of Bolts in one Row = 6 Bolts

The Number of Bolts in Plate = 12 Bolts

3- Tensile Force

$$T_{\text{ext}_b} = \frac{T_b}{\text{Number of Tension bolt}} = \frac{99.49}{6} = 17 \text{ t}$$

4- Prying Force

$$P = \left[\frac{0.5 - \left[\frac{W \times T_b^4}{30 \times a \times b^2 \times A_s} \right]}{\left(\frac{3 \times a}{4 \times b} \right) \times \left(\frac{a}{4 \times b} + 1 \right) + \left[\frac{W \times T_b^4}{30 \times a \times b^2 \times A_s} \right]} \right] \times T_{\text{ext}_b} =$$

$$P = \left[\frac{0.5 - \left[\frac{224}{13237.5} \right]}{\left(\frac{15}{20} \right) \times (0.25 + 1) + \left[\frac{224}{13237.5} \right]} \right] \times 17$$

$$P = 5.64 \text{ t}$$

Check of bolts:

$$T_{\text{ext}_b} + P \leq 0.8 \times T$$

$$16.6 + 5.64 \leq 0.8 \times 35.34$$

$$22.22 \leq 28.27 \quad \text{O.K.}$$

Check of shear:

$$V_b = \frac{V_{\text{max}}}{n} = \frac{21.7}{12} = 1.8 \text{ t}$$

$$V_b < P_s$$

$$1.81 < 14.13 \quad \text{O.K.}$$

Design of end plates:

Allowable Stress in Bending
$F_c = 0.64 \times F_y = 0.64 \times 3.60 = 2.3 \text{ t/cm}^2$

Size around the flange
$T_b = \frac{M_{\max(\text{ASD})}}{h - t_f} = \frac{43.32 \times 100}{45 - 1.46} = 65.9 \text{ t}$

Moment
$M = \frac{T_p \times L}{8} = \frac{65.9 \times 27}{8} = 223 \text{ t-cm}$

Thickness of Plate
$t_p = \sqrt{\frac{6 \times M}{2 \times w \times F_c}} = \sqrt{\frac{6 \times 223}{2 \times 15 \times 2.30}} = 4 \text{ cm}$

Plate Size	
Thickness of Plate =	4 cm
Length of Plate =	27 cm
Wedith of Plate =	20 cm

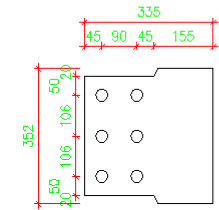
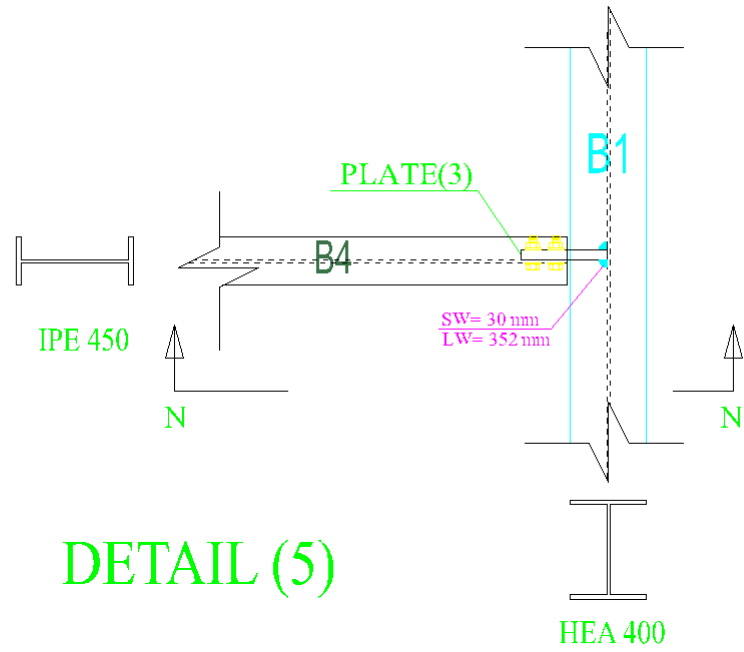
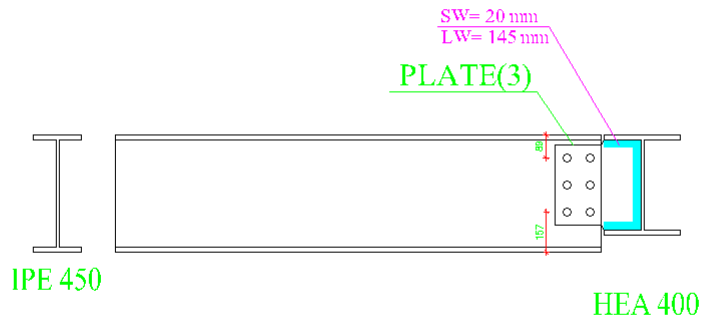

PLATE (3)
 PL 352 x 335 X40
 6M30 (10.9)
 HOLE DIAM 32mm



SECTION (N-N)

AutoCad Connection Drawing for Simple Connection in Mezzanine Floor

3.5.2 Connection of Roof:

3.5.2.1 Moment Connection (column HEB 400 with beam IPE360):

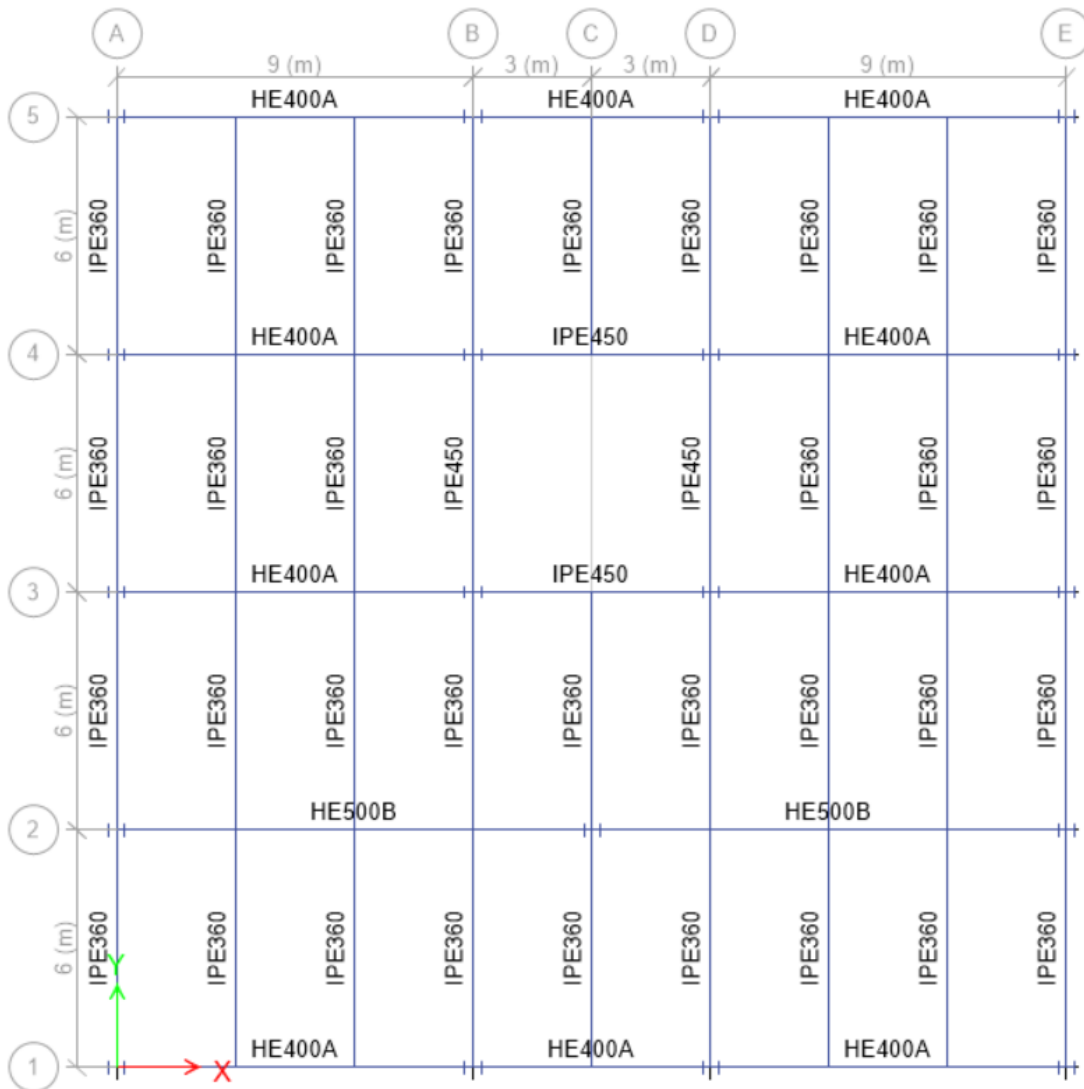

Figure 58 Roof plan - Connection

Material specification:

Material: steel grade (36)		
F_y	3.6	t/cm ²
F_u	5.2	t/cm ²

Bolts		
D	24	mm
Grade	10.9	-
A_s	3.53	cm ²
T	22.23	t
P_s	10.6	t

Section properties:

Column Section (HEB400)		
h	400	mm
h _i	352	mm
b _f	300	mm
t _w	13.5	mm
t _f	24	mm
r	27	mm
A	198	cm ²
I _x	57680	cm ⁴

Beam Section (IPE360)		
h	360	mm
h _i	334.6	mm
b _f	170	mm
t _w	8	mm
t _f	12.7	mm
r	18	mm
A	72.7	cm ²
I _x	16270	cm ⁴

Loading :

Analysis of Moment and Shear (ASD Method)			
Dead Load =	4.078	t-m	
Live Load =	3	t-m	
Ultimated Load =		DL + LL	
	1.05	+ 0.38	= 1.430 t-m

Calculating for Moment and Shear	
$M_{\max} = \frac{W_u \times L^2}{12} = \frac{1.43 \times 12^2}{12} = 17.16 \text{ t-m}$	
$V_{\max} = \frac{W_u \times L}{2} = \frac{1.43 \times 12}{2} = 8.58 \text{ t}$	

Combined Connection Bolts and Welds	
$M_{b \text{ and } w} = \frac{M_{\max}}{2} = \frac{17.16}{2} = 8.58 \text{ t-m}$	
$V_{b \text{ and } w} = \frac{V_{\max}}{2} = \frac{8.58}{2} = 4.29 \text{ t}$	

Design of welding:

1- Length of weld lines around the flange for Beam

$$L_f = b_f + (b_f - t_w - 2 \times t_f) =$$

$$L_f = 17 + (17 - 0.8 - 2 \times 1.27) = \mathbf{30.66 \text{ cm}}$$

2 -Welding size around the flange

$$T_b = \frac{M_{\max(\text{ASD})}}{h - t_f} = \frac{8.58 \times 100}{36 - 1.27} = \mathbf{24.70 \text{ t}}$$

3 -The Stress of Welding

$$F_{pw} = 0.2 \times F_u =$$

$$F_{pw} = 0.2 \times 5.2 = \mathbf{1.04 \text{ t/cm}^2}$$

4 -The Thickness of welding around the Flange

$$S_w = \frac{T_b}{L_f \times F_{pw}} = \frac{24.70}{30.66 \times 1.04} = \mathbf{0.77 \text{ cm}}$$

Take $S_w = \mathbf{1 \text{ cm}}$

5 - Length of weld lines around the Web of Beam

$$L_w = 2 \times (b_f - 2 \times t_f) =$$

$$L_w = 2 \times (17 - 2 \times 1.27) = \mathbf{28.9 \text{ cm}}$$

6 - The Thickness of welding around the Web

$$S_w = \frac{V_b}{L_w \times F_{pw}} = \frac{4.29}{28.9 \times 1.04} = \mathbf{0.14 \text{ cm}}$$

Take $S_w = \mathbf{1 \text{ cm}}$

The Total Thickness of Welding around Web and Flange

$$S_w = \mathbf{1 \text{ cm}}$$

Properties of new beam section

$S_w = 10 \text{ mm}$
$C = b_f / 2 - S_w - (t_w / 2) =$
$C = 300 / 2 - 10 - (8.0 / 2) = 136 \text{ mm}$
$d_w = h_1 - (S_w \times 2) =$
$d_w = 335 - (10 \times 2) = 315 \text{ mm}$
$X_1 = d_w / 2 + S_w =$
$X_1 = 315 / 2 + 10 = 187 \text{ mm}$
$X_2 = X_1 + t_f =$
$X_2 = 187 + 13 = 200 \text{ mm}$

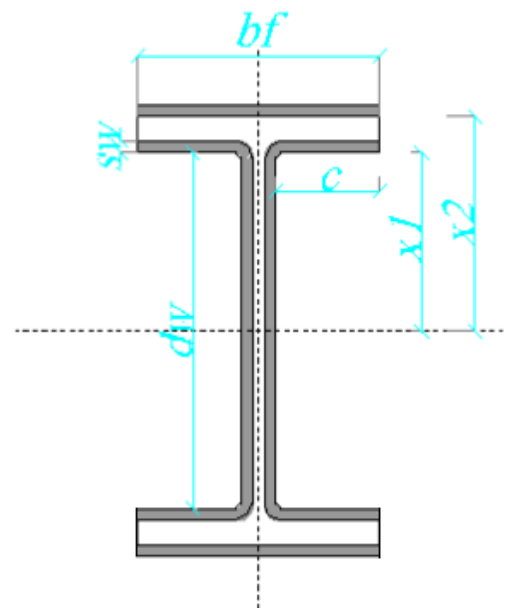

Checking the safety of welding:

1- Area of Welding

$$A_w = (2 \times d_w \times S_w) + (2 \times d_f \times S_w) + (4 \times C \times S_w) =$$
$$A_w = (2 \times 31 \times 1) + (2 \times 30 \times 1) + (4 \times 13.60 \times 1) = 177.32 \text{ cm}^2$$

2- Inertia Moment of Welding Section

$$I_{xw} = \left(\frac{d_w^3 \times S_w}{12} \times 2 \right) + \left(\frac{C \times S_w^3}{12} \times 4 \right) + (C \times S_w \times X_1^2 \times 4) + \left(\frac{b_f \times S_w^3}{12} \times 2 \right) + (b_f \times S_w \times X_2^2 \times 4) =$$
$$I_{xw} = \left(\frac{31137}{12} \times 2 \right) + \left(\frac{13.6}{12} \times 4 \right) + (13.60 \times 1 \times 350.8 \times 4) + \left(\frac{30}{12} \times 2 \right) + (30 \times 1 \times 4000 \times 4) = 504283.25 \text{ cm}^4$$

3- Tensile Stress

$$F_t = \frac{M_{\max} \times y}{I_{xw}} = \frac{1716 \times 25}{504283.25} = 0.08507 \text{ t/cm}^2$$

4- Gross Effective Area

$$q = \frac{V}{2 \times S_w \times d_w} = \frac{8.6}{2 \times 1 \times 31.5} = 0.136 \text{ t/cm}^2$$

5- Equivalent Stress

$$F_{eq} = \sqrt{F_t^2 + 3q^2} = \sqrt{0.08507^2 + 3 \times 0.136^2} = 0.141 \text{ t/cm}^2$$

6- Allowable Stress

$$F_{allw} = 1.1 \times F_{pw} = 1.1 \times 1 = 1.1 \text{ t/cm}^2$$

7- Check the safety of welding

$$F_{eq} < F_{allw} \quad \checkmark$$

$$0.141 < 1.14$$

Design of Bolts:

1- Number of Bolts

$$T_b = \frac{M_{\max(ASD)}}{h - t_f} = \frac{8.58 \times 100}{36 - 1.27} = 24.70 \text{ t}$$

$$N_b = \frac{T_b}{T} = \frac{24.70}{22.23} = 1.11$$

The Number of Bolts in one Row = 3 Bolts

The Number of Bolts in Plate = 6 Bolts

2- Tensile Force

$$T_{\text{tension}} = \frac{T_b}{\text{Number of Tension bolt}} = \frac{9}{4} = 2.1 \text{ t}$$

3- Prying Force

$$P = \left[\frac{0.5 - \left[\frac{W \times T_b^4}{30 \times a \times b^2 \times A_s} \right]}{\left(\frac{3 \times a}{4 \times b} \right) \times \left(\frac{a}{4 \times b} + 1 \right) + \left[\frac{W \times T_b^4}{30 \times a \times b^2 \times A_s} \right]} \right] \times T_{\text{tension}} =$$

$$P = \left[\frac{0.5 - \left[\frac{224}{13237.5} \right]}{\left(\frac{15}{20} \right) \times (0.25 + 1) + \left[\frac{224}{13237.5} \right]} \right] \times 2$$

$$P = 0.73 \text{ t}$$

Checking of Bolts:

$$T_{ext_b} + P \leq 0.8 \times T$$

$$2.1 + 0.73 \leq 0.8 \times 22.23$$

$$2.87 \leq 17.78 \quad \text{O.K.}$$

Design of Shear:

$$V_b = \frac{V_{\max}}{n} = \frac{4.3}{6} = 0.7 \text{ t}$$

$$V_b < P_s$$

$$0.72 < 10.60 \quad \text{O.K.}$$

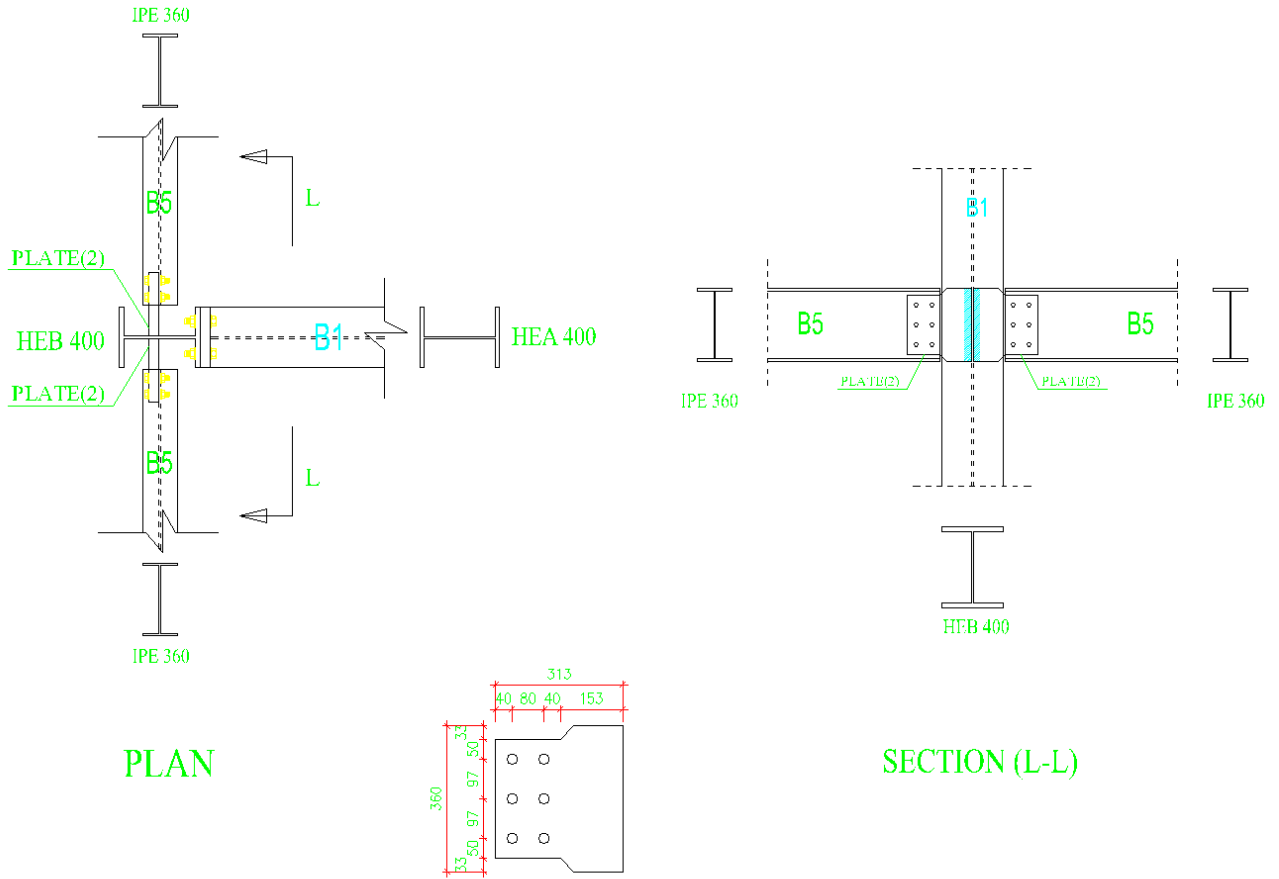

PLATE (2)
 PL 360 x 313 X50
 6M24 (10.9)
 HOLE DIAM 26mm

AutoCad Connection Drawing for Moment Connection in Roof

3.5.2.2 Simple Connection of Roof (beam HEA 400 with IPE 360):

Material Specification

Material: steel grade (36)		
F_y	3.6	t/cm ²
F_u	5.2	t/cm ²

Bolts		
D	30	mm
Grade	10.9	-
A_s	5.61	cm ²
T	35.34	t
P_s	14.13	t

Section Properties

Beam Section (HEA 400)		
h	390	mm
h_i	352	mm
b_f	300	mm
t_w	11	mm
t_f	24	mm
r	27	mm
A	195	cm ²
I_x	45070	cm ⁴

Beam Section (IPE 360)		
h	360	mm
h_i	334.6	mm
b_f	170	mm
t_w	8	mm
t_f	12.7	mm
r	18	mm
A	72.7	cm ²
I_x	16270	cm ⁴

Loading

Analysis of Moment and Shear (ASD Method)			
Dead Load =	4.078	t-m	
Live Load =	3	t-m	
Ultimated Load =	DL	+	LL
	2.11	+	0.75 = 2.860 t-m

Calculating for Moment and Shear	
$M_{\max} = \frac{W_u \times L^2}{12} = \frac{2.86 \times 12^2}{12} = 34.32 \text{ t-m}$	
$V_{\max} = \frac{W_u \times L}{2} = \frac{2.86 \times 12}{2} = 17.16 \text{ t}$	

Design of welding:

1- Length of weld lines around the flange for Beam

$$L_f = b_f + (b_f - t_w - 2 \times t_f) =$$

$$L_f = 17 + (17 - 0.8 - 2 \times 1.27) = \mathbf{30.66 \text{ cm}}$$

2 -Welding size around the flange

$$T_b = \frac{M_{\max(\text{ASD})}}{h - t_f} = \frac{34.32 \times 100}{36 - 1.27} = \mathbf{98.82 \text{ t}}$$

3 -The Stress of Welding

$$F_{pw} = 0.2 \times F_u =$$

$$F_{pw} = 0.2 \times 5.2 = \mathbf{1.04 \text{ t/cm}^2}$$

4 -The Thickness of welding around the Flange

$$S_w = \frac{T_b}{L_f \times F_{pw}} = \frac{98.82}{30.66 \times 1.04} = \mathbf{3 \text{ cm}}$$

Take $S_w = \mathbf{3 \text{ cm}}$

5 - Length of weld lines around the Web of Beam

$$L_w = 2 \times (b_f - 2 \times t_f) =$$

$$L_w = 2 \times (17 - 2 \times 1.27) = \mathbf{28.9 \text{ cm}}$$

6 - The Thickness of welding around the Web

$$S_w = \frac{V_b}{L_w \times F_{pw}} = \frac{17.16}{28.9 \times 1.04} = \mathbf{0.57 \text{ cm}}$$

Take $S_w = \mathbf{1 \text{ cm}}$

The Total Thickness of Welding around Web and Flange

$$S_w = \mathbf{3 \text{ cm}}$$

Design of Bolts:

1- Prestressing for angle Plate Double Shear

$$T_d = \frac{T}{2} = \frac{35.34}{2} = \mathbf{17.67 \text{ t}}$$

2- Number of Bolts

$$T_b = \frac{M_{\max(\text{ASD})}}{h - t_f} = \frac{34.32 \times 100}{36 - 1.27} = \mathbf{98.82 \text{ t}}$$

$$N_b = \frac{T_b}{T_d} = \frac{98.82}{17.67} = \mathbf{5.59}$$

The Number of Bolts in one Row = $\mathbf{6 \text{ Bolts}}$

The Number of Bolts in Plate = $\mathbf{12 \text{ Bolts}}$

3- Tensile Force

$$\text{Text}_b = \frac{T_b}{\text{Number of Tension bolt}} = \frac{98.82}{6} = 16 \text{ t}$$

4- Prying Force

$$P = \left[\frac{0.5 - \left[\frac{W \times T_b^4}{30 \times a \times b^2 \times A_s} \right]}{\left(\frac{3 \times a}{4 \times b} \right) \times \left(\frac{a}{4 \times b} + 1 \right) + \left[\frac{W \times T_b^4}{30 \times a \times b^2 \times A_s} \right]} \right] \times \text{Text}_b =$$

$$P = \left[\frac{0.5 - \left[\frac{224}{13237.5} \right]}{\left(\frac{15}{20} \right) \times (0.25 + 1) + \left[\frac{224}{13237.5} \right]} \right] \times 16$$

$$P = 5.60 \text{ t}$$

Checking for Bolts:

$$\text{Text}_b + P \leq 0.8 \times T$$

$$16.5 + 5.60 \leq 0.8 \times 35.34$$

$$22.07 \leq 28.27 \quad \text{O.K.}$$

Checking for Shear:

$$V_b = \frac{V_{\max}}{n} = \frac{17.2}{12} = 1.4 \text{ t}$$

$$V_b < P_s$$

$$1.43 < 14.13 \quad \text{O.K.}$$

Design of end plates:

Allowable Stress in Bending
$F_c = 0.64 \times F_y = 0.64 \times 3.60 = 2.3 \text{ t/cm}^2$

Size around the flange
$T_b = \frac{M_{\max(\text{ASD})}}{h - t_f} = \frac{34.32 \times 100}{36 - 1.27} = 75.1 \text{ t}$

Moment
$M = \frac{T_p \times L}{8} = \frac{75.1 \times 25}{8} = 235 \text{ t-cm}$

Thickness of Plate
$t_p = \sqrt{\frac{6 \times M}{2 \times w \times F_c}} = \sqrt{\frac{6 \times 235}{2 \times 15 \times 2.30}} = 5 \text{ cm}$

Plate Size	
Thickness of Plate =	5 cm
Length of Plate =	25 cm
Width of Plate =	20 cm

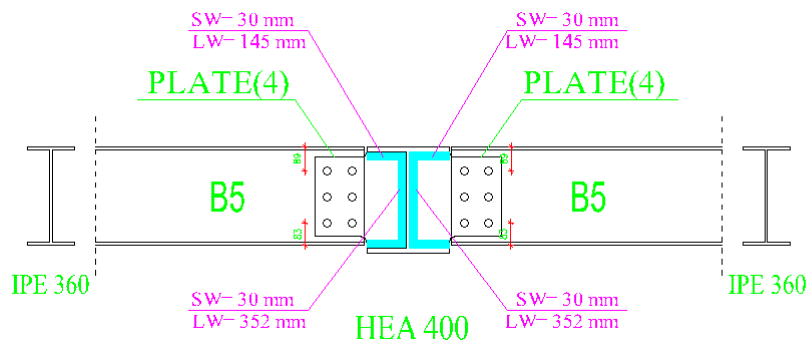
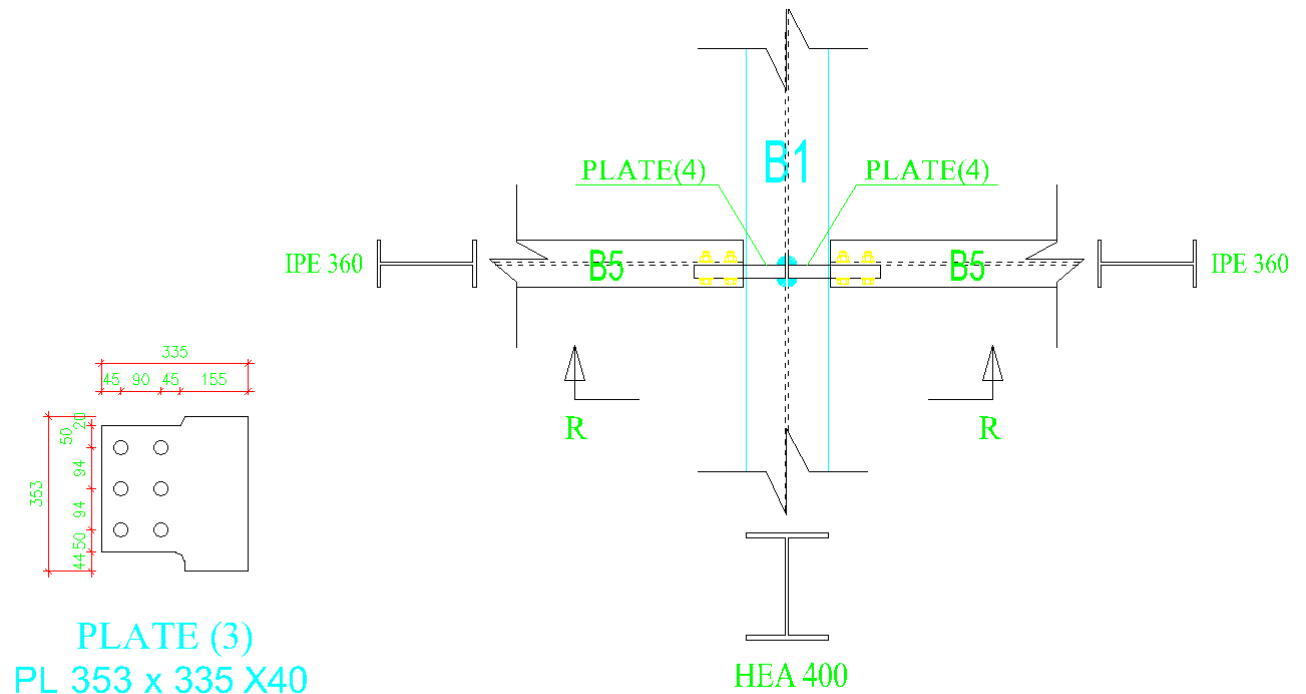

AutoCad Connection Drawing for Simple Connection in Roof

Summary for Connection in Mezzanine Floor:

Connection of Mezzanine Floor:

Connection	Detail		Type of Calculation	Repeated
	Beam	Column		
1	HEB 500	HEB 400	Excel Sheet	Along Grade 2
2	HEA 400	HEB 400	Limcon Software	Along Grade 1 and 5
3	IPE 450	HEB 400	Limcon Software	Along Grade A and E
4	HEA 450	HEB 400	Limcon Software	Along Grade 3

Excel Sheet
Calculation for
Moment
Connection

HEB 500
HEB 400

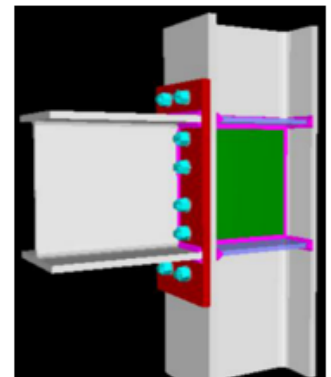
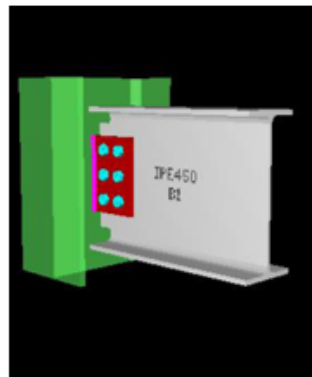
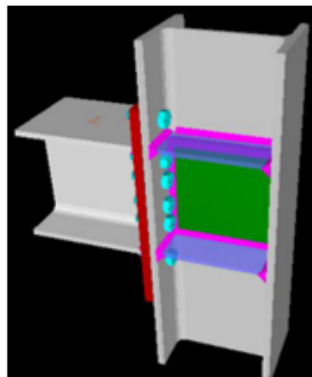

Connection 1

Connection 2

Connection 3

Connection 4

Connection of Sub-beam in Mezzanine Floor:

Connection	Detail		Type of Calculation	Repeated
	Beam	Beam		
5	HEA 400	IPE 450	Limcon Software	Along Grade 1 and 3

Note: The connection of sub-beam applied to the beam HEB 500 to be symmetrical.

Excel Sheet
Calculation for
Simple
Connection

HEA 400
IPE 450
Connection 5

Summary for Connection in Roof:

Connection of Roof:

Connection	Detail		Type of Calculation	Repeated
	Beam	Column		
1	HEB 500	HEB 400	Excel Sheet	Along Grade 2
2	HEA 400	HEB 400	Limcon Software	Along Grade 1-3-4 and 5
3	IPE 450	HEB 400	Limcon Software	3B - 3D - 4B 4D
4	IPE 360	HEB 400	Excel Sheet	Along Grade A-B-D and E

Note: Connection 2 and 4 it's applied without the connection in grade 3B - 3D - 4B and 4D (the area of Dome)

Excel Sheet
Calculation for
Moment
Connection

HEB 500
HEB 400

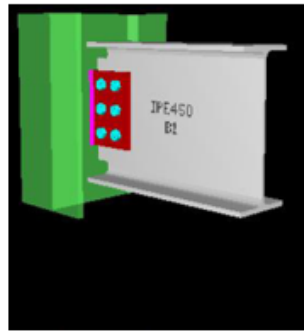
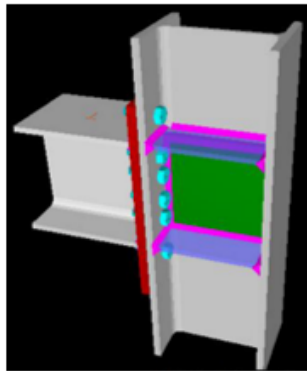

Excel Sheet
Calculation for
Moment
Connection

IPE 360
HEB 400

Connection 1

Connection 2

Connection 3

Connection 4

Connection of Sub-beam in Roof:

Connection	Detail		Type of Calculation	Repeated
	Beam	Beam		
6	HEA 400	IPE 360	Excel Sheet	Along Grade 1-2-3-4 and 5

Note: The connection of sub-beam applied to beam HEB 500 to be symmetrical.

Excel Sheet
Calculation for
Simple
Connection

HEA 400
IPE 360

Connection 6

Chapter 4: Foundation

4.1 Introduction

A foundation is the element of an architectural structure which connects it to the ground, and transfers loads from the structure to the ground. Foundations are generally considered either shallow or deep. This chapter is made for the mosque foundation design and a shallow foundation is going to be used for this project. This section includes the calculations and verification of the suitable foundation system for different elements of the mosque. We will first check for isolated foundation. If it does not work, then we will go directly for Raft foundation. In case of using raft foundation settlements calculation is required.

4.2 Isolated foundation

Isolated foundations (footings) are standalone families that are part of the structural foundation category. Several types of isolated foundations can be loaded from the family library, including pile caps with multiple piles, rectangular piles, and single piles.

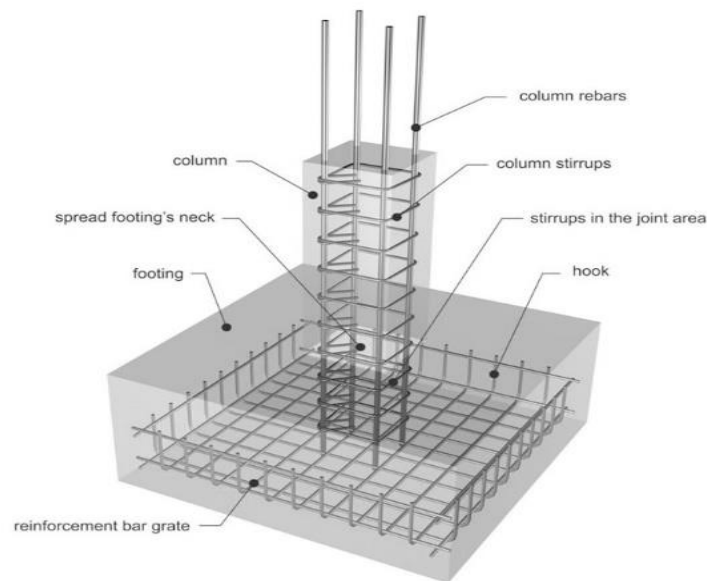

Figure 59 Isolated Foundation

4.3 Design of Isolated Foundation:

Analysis of Loading: defined the dead load and live load

1- Dead Load		
Slab Weight =	Thickness × Area × Density $0.25 \text{ m} \times (12 \text{ m} \times 6 \text{ m}) \times 2.5 \text{ t/m}^3$	Total 45 ton
Beam Weight =	Weight × Area $0.187 \text{ t/m} \times (12 \text{ m} + 6 \text{ m})$	3.37 ton
Sub-beam Weight =	Weight × Area $0.089 \text{ t/m} \times (6 \text{ m} \times 4 \text{ m})$	2.14 ton
Column Weight =	$0.125 \text{ t/m} \times 12 \text{ m}$	1.5 ton
Ceramic Weight =	$0.15 \text{ t/m} \times (12 \text{ m} \times 6 \text{ m})$	2.7 ton
Total Dead Load =		54.70 ton
2- Live Load		
Live Load =	$0.5 \text{ t/m} \times (12 \text{ m} \times 6 \text{ m})$	Total 36 ton

Properties and analysis to design the Foundation:

	Total
(A) Dead Load _(roof+1st floor) =	109 ton
(B) Live Load _(roof+1st floor) =	72 ton
(C) $\gamma_s = \frac{2}{1 + \beta} = \frac{2}{1 + 0.85}$	1.081 t/m ³
(D) $F_y =$	42,000 ton/m ²
(E) $\gamma_c =$	2.50 ton/m ³
(F) $F'_c =$ 30 MPa	2500 ton/m ²
(G) $\lambda = \frac{Kl}{r} =$	1
(H) $\beta = \rightarrow$ For concrete $F_y = 40$ MPa	0.85
(I) \emptyset Steel _{Diameter} 1.60 cm	0.016 m
(J) \emptyset Steel _{area} =	0.0126 m ²
Steel _{Diameter} According to the steel table from the European specification (53-62)	

Before proceeding a 90cm thick foundation-base is assumed:

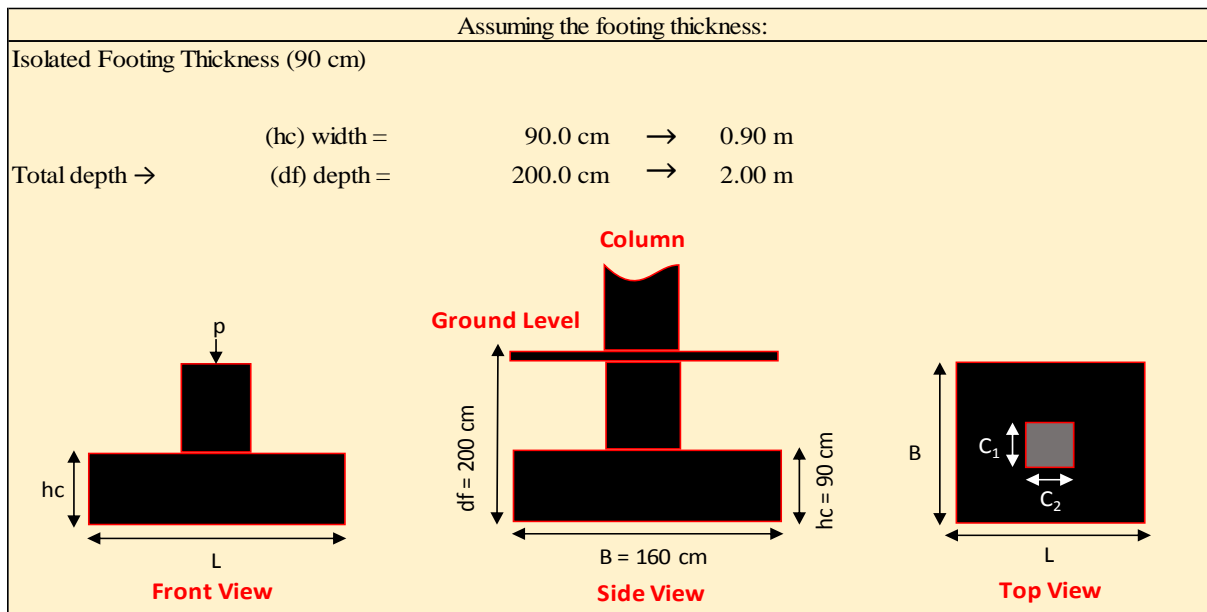
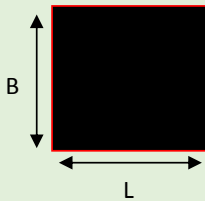



Figure 60 Foundation thickness and height assumption

The calculation are made based on ACI code and all the details are included in the Excel sheet in order to design the foundation:

1- Gross soil pressure	
Assuming the area: Area = (L x B) (0.7 m × 0.7 m)	Total 0.49 m ²
Use one way slab : $\frac{L}{B} \leq 2$	
Safety Factor : $\phi = 2.5$	
$q_{all(gross)} = \frac{p}{\phi \times A} = \frac{90.702}{2.5 \times 0.49}$	74.04 ton/m ²
According to ACI code safety factor can be used $\phi = 2.5 - 3.0$	

2- Allowable net soil	
$q_{all(net)} = q_{all(gross)} - \gamma_c (h_c) - \gamma_s (d_f - h_c)$	
$q_{all(net)} = 74.04 - 2.5 \times (0.9) - 1.081 \times (2.00 - 0.9)$	
	70.60 ton/m ²

3- Checking the Area	
$A_{req} = \frac{P_D + P_L}{q_{all(net)}}$	Total
$A_{req} = \frac{109 + 72}{70.60}$	2.57 m ²
$B = \sqrt{A_{req}}$	
$B = \sqrt{2.57}$ Because its one way slab then B = L	1.6 m

4- Soil Pressure	
$P_u = 1.2 \times \text{Dead Load} + 1.6 \times \text{Live Load}$	Total
$P_u = 1.2 \times 109.4 + 1.6 \times 72.0$	246.48 ton
$q_u(net) = \frac{1.2P_D + 1.6P_L}{L \times B} = \frac{246.48}{2.57}$	95.93 ton/m ²

5- Checking the thickness for Puncting shear

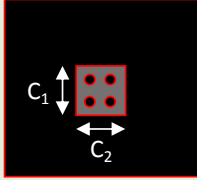
Diameter:		Total																																																																																																																								
$\text{Diameter}_{\text{avg}} = h_c - 7.5\text{cm} - \text{Bar diameter}$		82 cm 0.825 m																																																																																																																								
$\text{Diameter}_{\text{avg}} = 90 - 7.5 - 0.02$																																																																																																																										
Bar Diameter:																																																																																																																										
$\text{Bar}_{\text{diameter}} = C + d_{\text{avg}}$		1.225 m 1.225 m																																																																																																																								
1- 0.400 + 0.825 2- 0.400 + 0.825																																																																																																																										
According to the steel table from the European specification (53-62)																																																																																																																										
Actual Area of Steel																																																																																																																										
$H_t = H_c$ $A_s f_y = (0.85 f'_c a \times b)$ $A_s = \left(\frac{0.85 f'_c a \times b}{f_y} \right)$																																																																																																																										
$A_s = \frac{0.85 \times 2500.00 \times 0.49 \times 1.60}{42000}$		0.0397 m ² 1.562 in ²																																																																																																																								
→																																																																																																																										
<table border="1" style="margin: auto; border-collapse: collapse;"> <caption>Table 4. Areas of Multiple of Reinforcing Bars (in²)</caption> <thead> <tr> <th rowspan="2">Number of bars</th> <th colspan="10">Bar number</th> </tr> <tr> <th>#3</th> <th>#4</th> <th>#5</th> <th>#6</th> <th>#7</th> <th>#8</th> <th>#9</th> <th>#10</th> <th>#11</th> </tr> </thead> <tbody> <tr><td>1</td><td>0.11</td><td>0.20</td><td>0.31</td><td>0.44</td><td>0.60</td><td>0.79</td><td>1.00</td><td>1.27</td><td>1.56</td></tr> <tr><td>2</td><td>0.22</td><td>0.40</td><td>0.62</td><td>0.88</td><td>1.20</td><td>1.58</td><td>2.00</td><td>2.54</td><td>3.12</td></tr> <tr><td>3</td><td>0.33</td><td>0.60</td><td>0.93</td><td>1.32</td><td>1.80</td><td>2.37</td><td>3.00</td><td>3.81</td><td>4.68</td></tr> <tr><td>4</td><td>0.44</td><td>0.80</td><td>1.24</td><td>1.76</td><td>2.40</td><td>3.16</td><td>4.00</td><td>5.08</td><td>6.24</td></tr> <tr><td>5</td><td>0.55</td><td>1.00</td><td>1.55</td><td>2.20</td><td>3.00</td><td>3.95</td><td>5.00</td><td>6.35</td><td>7.80</td></tr> <tr><td>6</td><td>0.66</td><td>1.20</td><td>1.86</td><td>2.64</td><td>3.60</td><td>4.74</td><td>6.00</td><td>7.62</td><td>9.36</td></tr> <tr><td>7</td><td>0.77</td><td>1.40</td><td>2.17</td><td>3.08</td><td>4.20</td><td>5.53</td><td>7.00</td><td>8.89</td><td>10.92</td></tr> <tr><td>8</td><td>0.88</td><td>1.60</td><td>2.48</td><td>3.52</td><td>4.80</td><td>6.32</td><td>8.00</td><td>10.16</td><td>12.48</td></tr> <tr><td>9</td><td>0.99</td><td>1.80</td><td>2.79</td><td>3.96</td><td>5.40</td><td>7.11</td><td>9.00</td><td>11.43</td><td>14.04</td></tr> <tr><td>10</td><td>1.10</td><td>2.00</td><td>3.10</td><td>4.40</td><td>6.00</td><td>7.90</td><td>10.00</td><td>12.70</td><td>15.60</td></tr> </tbody> </table>			Number of bars	Bar number										#3	#4	#5	#6	#7	#8	#9	#10	#11	1	0.11	0.20	0.31	0.44	0.60	0.79	1.00	1.27	1.56	2	0.22	0.40	0.62	0.88	1.20	1.58	2.00	2.54	3.12	3	0.33	0.60	0.93	1.32	1.80	2.37	3.00	3.81	4.68	4	0.44	0.80	1.24	1.76	2.40	3.16	4.00	5.08	6.24	5	0.55	1.00	1.55	2.20	3.00	3.95	5.00	6.35	7.80	6	0.66	1.20	1.86	2.64	3.60	4.74	6.00	7.62	9.36	7	0.77	1.40	2.17	3.08	4.20	5.53	7.00	8.89	10.92	8	0.88	1.60	2.48	3.52	4.80	6.32	8.00	10.16	12.48	9	0.99	1.80	2.79	3.96	5.40	7.11	9.00	11.43	14.04	10	1.10	2.00	3.10	4.40	6.00	7.90	10.00	12.70	15.60
Number of bars	Bar number																																																																																																																									
	#3	#4	#5	#6	#7	#8	#9	#10	#11																																																																																																																	
1	0.11	0.20	0.31	0.44	0.60	0.79	1.00	1.27	1.56																																																																																																																	
2	0.22	0.40	0.62	0.88	1.20	1.58	2.00	2.54	3.12																																																																																																																	
3	0.33	0.60	0.93	1.32	1.80	2.37	3.00	3.81	4.68																																																																																																																	
4	0.44	0.80	1.24	1.76	2.40	3.16	4.00	5.08	6.24																																																																																																																	
5	0.55	1.00	1.55	2.20	3.00	3.95	5.00	6.35	7.80																																																																																																																	
6	0.66	1.20	1.86	2.64	3.60	4.74	6.00	7.62	9.36																																																																																																																	
7	0.77	1.40	2.17	3.08	4.20	5.53	7.00	8.89	10.92																																																																																																																	
8	0.88	1.60	2.48	3.52	4.80	6.32	8.00	10.16	12.48																																																																																																																	
9	0.99	1.80	2.79	3.96	5.40	7.11	9.00	11.43	14.04																																																																																																																	
10	1.10	2.00	3.10	4.40	6.00	7.90	10.00	12.70	15.60																																																																																																																	
<div style="border: 1px solid black; padding: 5px; display: inline-block;">Take 8#4 Ø</div>	→	<div style="border: 1px solid black; padding: 5px; display: inline-block;">8 No. 4 bars</div>																																																																																																																								

Shear:								
Formula for concrete column we use:								
Ultimate shear (V_u):								
$V_u = q_u (net) \times [(L) \times B - (C_1 + d) \times (C_2 + d)]$ $V_u = (95.93) \times [(1.60) \times 1.60 - (1.225) \times (1.225)]$		102.56 ton						
(B_0) Checking:								
$B_0 = 4 \times C + d_{avg}$ $B_0 = 4 \times (0.4 + 0.825)$		4.90 m						
Concrete shear (V_c):								
$V_c = 0.53 \times \sqrt{f'c} \times \left(1 + \frac{2}{\beta}\right) \times \lambda \times b_0 \times d$ $0.53 \times \sqrt{2500} \times 1 + \left(\frac{2}{0.85}\right) \times 1 \times 4.90 \times 0.825$	-----→ ①	359.07 ton						
$V_c = \lambda \times \sqrt{f'c} \times b_0 \times d$ $1 \times \sqrt{2500} \times 4.90 \times 0.825$	-----→ ②	202.06 ton						
$V_c = 0.27 \times \left(\frac{A_s \times d}{b_0} + 2\right) \times \lambda \times \sqrt{f'c} \times b_0 \times d$ $0.27 \times \left(\frac{0.0126 \times 0.825}{4.90} + 2\right) \times 1 \times \sqrt{2500} \times 4.90 \times 0.825$	-----→ ③	109.23 ton						
Check:								
<table border="1" style="margin: auto;"> <tr> <td>V_c</td> <td>></td> <td>V_u</td> </tr> <tr> <td>109.23</td> <td>></td> <td>102.56</td> </tr> </table>		V_c	>	V_u	109.23	>	102.56	
V_c	>	V_u						
109.23	>	102.56						
Safe								

6- Checking for beam shear		Total						
$\phi V_c = 0.75 \times 0.53 \times \sqrt{f'c} \times L \times d$ $\phi V_c = 0.75 \times 0.53 \times \sqrt{2500} \times 1.60 \times 0.825$		26.28 ton						
$V_u = q_u(net) L \left[\left(\frac{B - C_1}{2} \right) - d \right]$ $V_u = 95.9 \times 1.60 \left[\frac{1.60 - 0.400}{2} - 0.825 \right]$		-34.35 ton						
Check:								
<table border="1"> <tr> <td>ϕV_c</td> <td>></td> <td>V_u</td> </tr> <tr> <td>26.28</td> <td>></td> <td>-34.35</td> </tr> </table>		ϕV_c	>	V_u	26.28	>	-34.35	
ϕV_c	>	V_u						
26.28	>	-34.35						
Safe								

7- Compute the area of flexural reinforcement in each direction		Total
<p>a- Reinforcement in the long direction:</p> $M_u = qu(net) \frac{B}{2} \times \left(\frac{L - C_2}{2} \right)$ $95.93 \times \left(\frac{1.60}{2} \right) \times \left(\frac{1.60 - 0.40}{2} \right)^2$		117.09 ton-m ²
<p>b- Reinforcement in the short direction:</p> $M_u = qu(net) \frac{L}{2} \times \left(\frac{B - C_1}{2} \right)$ $95.93 \times \left(\frac{1.60}{2} \right) \times \left(\frac{1.60 - 0.40}{2} \right)^2$		117.09 ton-m ²

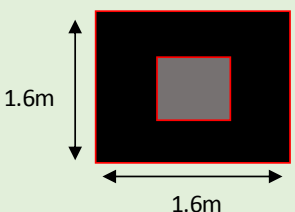
8- Check for bearing strength of column and footing concrete							
For supported column, the bearing capacity ϕP_n is:	Total						
$\phi P_n = \phi(0.85 f'c A_1)$ $\phi = 0.65$ <p>A_1 = Cross sectional area of column</p> <p>Critical column area = $159 \text{ cm}^2 \rightarrow 1.59 \text{ m}^2$</p> $0.65 \times (0.85 \times 2500 \times 1.59)$	2196.2 ton/m ²						
$\phi P_n = 2\phi(0.85 f'c A_1)$ $2 \times 0.65 \times (0.85 \times 2500 \times 1.59)$ <p>ϕ = Strength reduction factor for bearing = 0.65 according to ACI code</p>		4392.4 ton/m ²					
For a supporting footing:							
<p>A_2 = Cross sectional area of lower base:</p> <p>$A_2 = 2.6 \text{ m}^2$</p> <div style="display: flex; align-items: center; justify-content: center;"> <div style="margin-right: 20px;"> $\phi P_n = \phi(0.85 f'c A_1) \sqrt{\frac{A_2}{A_1}} \leq 2.0\phi(0.85 f'c A_1)$ $0.65 \times (0.85 \times 2500 \times 1.59) \times \sqrt{\frac{2.6}{1.59}}$ </div>  </div>							
Check:							
<table border="1" style="margin: auto;"> <tr> <td style="padding: 5px;">ϕP_n column</td> <td style="padding: 5px;">></td> <td style="padding: 5px;">ϕP_n footing</td> </tr> <tr> <td style="padding: 5px;">4392.38</td> <td style="padding: 5px;">></td> <td style="padding: 5px;">2791.78</td> </tr> </table>		ϕP_n column	>	ϕP_n footing	4392.38	>	2791.78
ϕP_n column	>	ϕP_n footing					
4392.38	>	2791.78					
For columns, minimum dowel reinforcement is given by ACI Code 15.8.2.1 as:							
$A_{s, \min} = 0.005 A_g$ $0.005 \times 159 \text{ cm}^2 \rightarrow 1.59 \text{ m}^2$		0.795 cm ² 0.00795 m ²					
Required dowel reinforcement is give by:							
$A_{s, req} = \frac{(\phi P_n - Pu)}{\phi fy}$ $\frac{(2791.78 - 246.48)}{0.65 \times 2500}$		1.57 m ²					

Appendix

Appendix A: Analysis & design report using ETABS 2015

ETABS[®] 2015
Integrated Building Design Software

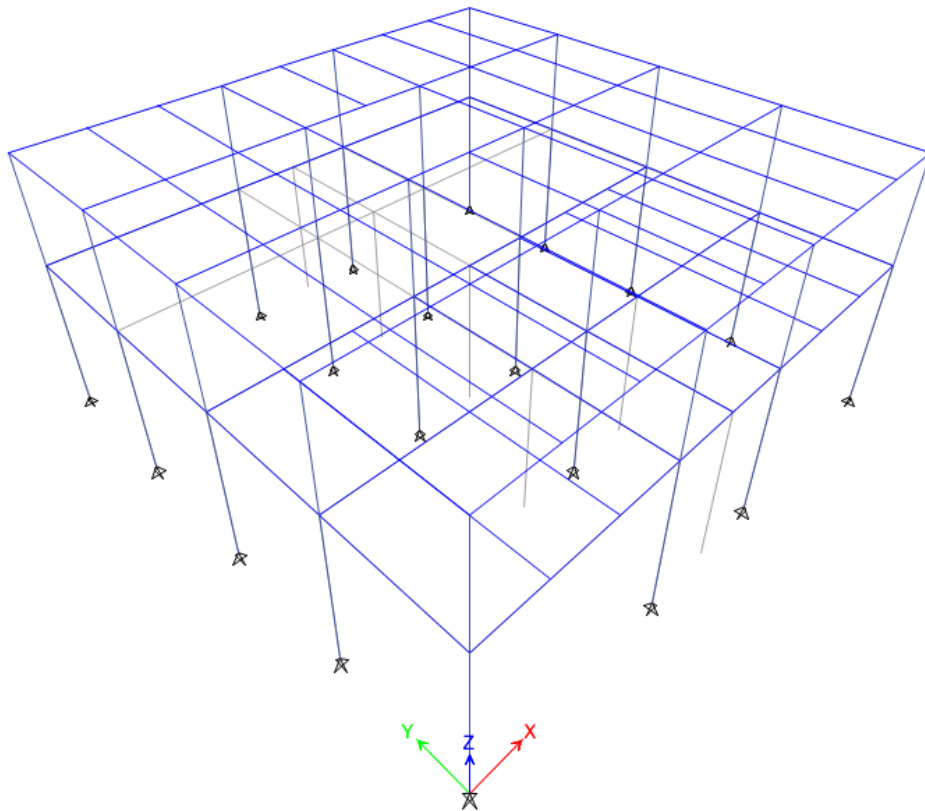

2.6.1 Structure Data

This chapter provides model geometry information, including items such as story levels, point coordinates, and element connectivity.

a) Story Data

Name	Height mm	Elevation n mm	Master Story	Similar To	Splice Story
Story2	5000	12000	Yes	None	No
Story1	7000	7000	No	Story2	No
Base	0	0	No	None	No

b) Grid Data

Name	Type	Story Range	X Origin m	Y Origin m	Rotatio n deg	Bubble Size mm	Color
G1	Cartesian	Default	0	0	0	1250	

Table 1.3 - Grid Lines

Grid System	Grid Direction	Grid ID	Visible	Bubble Location	Ordinate
G1	X	A	Yes	End	0
G1	X	B	Yes	End	9
G1	X	C	Yes	End	12
G1	X	D	Yes	End	15
G1	X	E	Yes	End	24
G1	Y	1	Yes	Start	0
G1	Y	2	Yes	Start	6
G1	Y	3	Yes	Start	12
G1	Y	4	Yes	Start	18
G1	Y	5	Yes	Start	24

c) Point Coordinates

Joint Coordinates Data

Label	X mm	Y mm	ΔZ Below mm
1	24000	0	0
2	12000	0	0
3	0	0	0
4	24000	6000	0
5	12000	6000	0
6	0	6000	0
7	24000	12000	0
9	0	12000	0
10	24000	18000	0
12	0	18000	0
13	24000	24000	0
14	12000	24000	0
15	0	24000	0
16	15000	12000	0
17	9000	12000	0
8	15000	18000	0
18	9000	18000	0
11	12000	12000	0
19	12000	18000	0
20	3000	0	0
21	6000	0	0
22	9000	0	0
23	15000	0	0
24	18000	0	0
25	21000	0	0
26	15000	6000	0
27	18000	6000	0
28	21000	6000	0
29	3000	6000	0
30	6000	6000	0
31	9000	6000	0
32	21000	12000	0
33	18000	12000	0
34	6000	12000	0

Label	X mm	Y mm	ΔZ Below mm
35	3000	12000	0
36	21000	18000	0
37	18000	18000	0
38	6000	18000	0
39	3000	18000	0
40	21000	24000	0
41	18000	24000	0
42	6000	24000	0
43	3000	24000	0
44	15000	24000	0
45	9000	24000	0

d) line Connectivity

Column Connectivity Data

Column	I-End Point	J-End Point	I-End Story
C1	1	1	Below
C3	3	3	Below
C4	4	4	Below
C5	5	5	Below
C6	6	6	Below
C7	7	7	Below
C9	9	9	Below
C10	10	10	Below
C12	12	12	Below
C13	13	13	Below
C15	15	15	Below
C16	16	16	Below
C17	17	17	Below
C8	8	8	Below
C18	18	18	Below
C11	44	44	Below
C21	45	45	Below
C14	23	23	Below
C19	22	22	Below

Beam Connectivity Data

Beam	I-End Point	J-End Point	Curve Type
B1	1	4	None
B2	4	7	None
B3	7	10	None
B4	10	13	None
B7	12	15	None
B8	9	12	None
B9	6	9	None
B10	3	6	None
B13	2	5	None
B14	5	4	None
B15	6	5	None
B16	16	7	None
B17	17	16	None
B18	9	17	None
B19	5	11	None
B20	8	10	None
B21	18	8	None
B22	12	18	None
B23	19	14	None
B24	16	8	None
B25	17	18	None
B42	25	28	None
B43	24	27	None
B44	23	26	None
B45	22	31	None
B46	21	30	None
B47	20	29	None
B48	28	32	None
B49	27	33	None
B50	26	16	None
B51	31	17	None
B52	30	34	None
B53	29	35	None
B26	32	36	None
B27	33	37	None
B28	34	38	None
B29	35	39	None
B30	36	40	None

Beam	I-End Point	J-End Point	Curve Type
B31	37	41	None
B32	38	42	None
B33	39	43	None
B34	8	44	None
B35	18	45	None
B36	44	13	None
B37	14	44	None
B39	45	14	None
B40	15	45	None
B5	45	44	None
B60	3	22	None
B62	23	1	None
B63	22	23	None

e) Mass

Mass Source

Name	Include Elements	Include Added Mass	Include Loads	Include Lateral	Include Vertical	Lump at Stories	IsDefault
MsSrc1	Yes	Yes	No	Yes	No	Yes	Yes

f) Groups

Group Definitions

Name	Color
All	Yellow

2.6.2 Properties

This chapter provides property information for materials, frame sections, shell sections, and links.

a) Materials

Material Properties - Summary

Name	Type	E MPa	v	Unit Weight kN/m ³	Design Strengths
4000Psi	Concrete	24855.58	0.2	23.5631	F _c =27.58 MPa
A615Gr60	Rebar	199947.98	0.3	76.9729	F _y =413.69 MPa, F _u =620.53 MPa

b) Frame Sections

Frame Sections - Summary

Name	Material	Shape
Column	4000Psi	Concrete Rectangular
Girder	4000Psi	Concrete Rectangular
Sub-beam	4000Psi	Concrete Rectangular

c) Reinforcement Sizes

Reinforcing Bar Sizes

Name	Diameter mm	Area mm ²
10	10	79
20	20	314

2.6.3 Assignments

This chapter provides a listing of the assignments applied to the model.

a) Joint Assignments

Joint Assignments - Summary

Story	Label	Unique Name	Diaphragm	Restrains
Story2	1	3	From Area	
Story2	2	6	From Area	
Story2	3	9	From Area	
Story2	4	14	From Area	
Story2	5	16	From Area	
Story2	6	18	From Area	
Story2	7	23	From Area	
Story2	9	27	From Area	
Story2	10	32	From Area	
Story2	12	36	From Area	
Story2	13	41	From Area	
Story2	14	43	From Area	
Story2	15	45	From Area	
Story2	16	48	From Area	
Story2	17	51	From Area	
Story2	8	52	From Area	
Story2	18	54	From Area	
Story2	11	33	From Area	
Story2	19	34	From Area	
Story2	20	81	From Area	
Story2	21	79	From Area	
Story2	22	77	From Area	
Story2	23	75	From Area	
Story2	24	73	From Area	
Story2	25	71	From Area	
Story2	26	76	From Area	
Story2	27	74	From Area	
Story2	28	72	From Area	
Story2	29	82	From Area	
Story2	30	80	From Area	
Story2	31	78	From Area	
Story2	32	83	From Area	
Story2	33	84	From Area	

Story	Label	Unique Name	Diaphragm	Restraints
Story2	34	85	From Area	
Story2	35	86	From Area	
Story2	36	87	From Area	
Story2	37	88	From Area	
Story2	38	89	From Area	
Story2	39	90	From Area	
Story2	40	91	From Area	
Story2	41	92	From Area	
Story2	42	93	From Area	
Story2	43	94	From Area	
Story2	44	95	From Area	
Story2	45	96	From Area	
Story1	1	2	From Area	
Story1	2	5	From Area	
Story1	3	8	From Area	
Story1	4	13	From Area	
Story1	5	15	From Area	
Story1	6	17	From Area	
Story1	7	22	From Area	
Story1	9	26	From Area	
Story1	10	31	From Area	
Story1	12	35	From Area	
Story1	13	40	From Area	
Story1	15	44	From Area	
Story1	16	47	From Area	
Story1	17	50	From Area	
Story1	8	25	From Area	
Story1	18	53	From Area	
Story1	11	29	From Area	
Story1	20	55	From Area	
Story1	21	56	From Area	
Story1	22	57	From Area	
Story1	23	58	From Area	
Story1	24	59	From Area	
Story1	25	60	From Area	
Story1	26	61	From Area	
Story1	27	62	From Area	
Story1	28	63	From Area	
Story1	29	64	From Area	

Story	Label	Unique Name	Diaphragm	Restraints
Story1	30	65	From Area	
Story1	31	66	From Area	
Story1	32	67	From Area	
Story1	33	68	From Area	
Story1	34	69	From Area	
Story1	35	70	From Area	
Story1	44	38	From Area	
Story1	45	98	From Area	
Base	1	1	From Area	UX; UY; UZ
Base	3	7	From Area	UX; UY; UZ
Base	4	10	From Area	UX; UY; UZ
Base	5	11	From Area	UX; UY; UZ
Base	6	12	From Area	UX; UY; UZ
Base	7	19	From Area	UX; UY; UZ
Base	9	21	From Area	UX; UY; UZ
Base	10	28	From Area	UX; UY; UZ
Base	12	30	From Area	UX; UY; UZ
Base	13	37	From Area	UX; UY; UZ
Base	15	39	From Area	UX; UY; UZ
Base	16	46	From Area	UX; UY; UZ
Base	17	49	From Area	UX; UY; UZ
Base	8	20	From Area	UX; UY; UZ
Base	18	24	From Area	UX; UY; UZ
Base	22	97	From Area	UX; UY; UZ
Base	23	42	From Area	UX; UY; UZ
Base	44	100	From Area	UX; UY; UZ
Base	45	107	From Area	UX; UY; UZ

b) Frame Assignments

Frame Assignments - Summary

Story	Label	Unique Name	Design Type	Length mm	Analysis Section	Design Section	Max Station Spacing mm	Min Number Stations
Story2	C1	2	Column	5000	Column	Column		3
Story2	C3	6	Column	5000	Column	Column		3
Story2	C4	8	Column	5000	Column	Column		3
Story2	C5	10	Column	5000	Column	Column		3
Story2	C6	12	Column	5000	Column	Column		3
Story2	C7	14	Column	5000	Column	Column		3
Story2	C9	18	Column	5000	Column	Column		3
Story2	C10	20	Column	5000	Column	Column		3
Story2	C12	24	Column	5000	Column	Column		3
Story2	C13	26	Column	5000	Column	Column		3
Story2	C15	30	Column	5000	Column	Column		3
Story2	C16	32	Column	5000	Column	Column		3
Story2	C17	34	Column	5000	Column	Column		3
Story2	C8	16	Column	5000	Column	Column		3
Story2	C18	36	Column	5000	Column	Column		3
Story2	C11	117	Column	5000	Column	Column		3
Story2	C21	129	Column	5000	Column	Column		3
Story2	C14	40	Column	5000	Column	Column		3
Story2	C19	119	Column	5000	Column	Column		3
Story1	C1	1	Column	7000	Column	Column		3
Story1	C3	5	Column	7000	Column	Column		3
Story1	C4	7	Column	7000	Column	Column		3
Story1	C5	9	Column	7000	Column	Column		3
Story1	C6	11	Column	7000	Column	Column		3
Story1	C7	13	Column	7000	Column	Column		3
Story1	C9	17	Column	7000	Column	Column		3
Story1	C10	19	Column	7000	Column	Column		3
Story1	C12	23	Column	7000	Column	Column		3
Story1	C13	25	Column	7000	Column	Column		3
Story1	C15	29	Column	7000	Column	Column		3
Story1	C16	31	Column	7000	Column	Column		3
Story1	C17	33	Column	7000	Column	Column		3
Story1	C8	15	Column	7000	Column	Column		3

Story	Label	Unique Name	Design Type	Length mm	Analysis Section	Design Section	Max Station Spacing mm	Min Number Stations
Story1	C18	35	Column	7000	Column	Column		3
Story1	C11	116	Column	7000	Column	Column		3
Story1	C21	128	Column	7000	Column	Column		3
Story1	C14	39	Column	7000	Column	Column		3
Story1	C19	118	Column	7000	Column	Column		3
Story2	B1	54	Beam	6000	Girder	Girder	500	
Story2	B2	55	Beam	6000	Girder	Girder	500	
Story2	B3	56	Beam	6000	Girder	Girder	500	
Story2	B4	57	Beam	6000	Girder	Girder	500	
Story2	B7	60	Beam	6000	Girder	Girder	500	
Story2	B8	61	Beam	6000	Girder	Girder	500	
Story2	B9	62	Beam	6000	Girder	Girder	500	
Story2	B10	63	Beam	6000	Girder	Girder	500	
Story2	B13	66	Beam	6000	Girder	Girder	500	
Story2	B14	67	Beam	12000	Girder	Girder	500	
Story2	B15	68	Beam	12000	Girder	Girder	500	
Story2	B16	69	Beam	9000	Girder	Girder	500	
Story2	B17	70	Beam	6000	Girder	Girder	500	
Story2	B18	71	Beam	9000	Girder	Girder	500	
Story2	B19	72	Beam	6000	Girder	Girder	500	
Story2	B20	73	Beam	9000	Girder	Girder	500	
Story2	B21	74	Beam	6000	Girder	Girder	500	
Story2	B22	75	Beam	9000	Girder	Girder	500	
Story2	B23	76	Beam	6000	Girder	Girder	500	
Story2	B24	77	Beam	6000	Girder	Girder	500	
Story2	B25	78	Beam	6000	Girder	Girder	500	
Story2	B42	45	Beam	6000	Sub-beam	Sub-beam	500	
Story2	B43	46	Beam	6000	Sub-beam	Sub-beam	500	
Story2	B44	48	Beam	6000	Sub-beam	Sub-beam	500	
Story2	B45	49	Beam	6000	Sub-beam	Sub-beam	500	
Story2	B46	80	Beam	6000	Sub-beam	Sub-beam	500	

Story	Label	Unique Name	Design Type	Length mm	Analysis Section	Design Section	Max Station Spacing mm	Min Number Stations
Story2	B47	81	Beam	6000	Sub-beam	Sub-beam	500	
Story2	B48	82	Beam	6000	Sub-beam	Sub-beam	500	
Story2	B49	84	Beam	6000	Sub-beam	Sub-beam	500	
Story2	B50	85	Beam	6000	Sub-beam	Sub-beam	500	
Story2	B51	86	Beam	6000	Sub-beam	Sub-beam	500	
Story2	B52	88	Beam	6000	Sub-beam	Sub-beam	500	
Story2	B53	89	Beam	6000	Sub-beam	Sub-beam	500	
Story2	B26	90	Beam	6000	Sub-beam	Sub-beam	500	
Story2	B27	92	Beam	6000	Sub-beam	Sub-beam	500	
Story2	B28	93	Beam	6000	Sub-beam	Sub-beam	500	
Story2	B29	94	Beam	6000	Sub-beam	Sub-beam	500	
Story2	B30	107	Beam	6000	Sub-beam	Sub-beam	500	
Story2	B31	108	Beam	6000	Sub-beam	Sub-beam	500	
Story2	B32	109	Beam	6000	Sub-beam	Sub-beam	500	
Story2	B33	110	Beam	6000	Sub-beam	Sub-beam	500	
Story2	B34	111	Beam	6000	Sub-beam	Sub-beam	500	
Story2	B35	112	Beam	6000	Sub-beam	Sub-beam	500	
Story2	B36	114	Beam	9000	Girder	Girder	500	
Story2	B37	59	Beam	3000	Girder	Girder	500	
Story2	B39	58	Beam	3000	Girder	Girder	500	

Story	Label	Unique Name	Design Type	Length mm	Analysis Section	Design Section	Max Station Spacing mm	Min Number Stations
Story2	B40	115	Beam	9000	Girder	Girder	500	
Story2	B60	120	Beam	9000	Girder	Girder	500	
Story2	B62	125	Beam	9000	Girder	Girder	500	
Story2	B63	123	Beam	6000	Girder	Girder	500	
Story1	B1	21	Beam	6000	Girder	Girder	500	
Story1	B2	22	Beam	6000	Girder	Girder	500	
Story1	B3	37	Beam	6000	Girder	Girder	500	
Story1	B4	38	Beam	6000	Girder	Girder	500	
Story1	B7	41	Beam	6000	Girder	Girder	500	
Story1	B8	42	Beam	6000	Girder	Girder	500	
Story1	B9	43	Beam	6000	Girder	Girder	500	
Story1	B10	44	Beam	6000	Girder	Girder	500	
Story1	B13	47	Beam	6000	Girder	Girder	500	
Story1	B14	87	Beam	12000	Girder	Girder	500	
Story1	B15	91	Beam	12000	Girder	Girder	500	
Story1	B16	50	Beam	9000	Girder	Girder	500	
Story1	B17	51	Beam	6000	Girder	Girder	500	
Story1	B18	52	Beam	9000	Girder	Girder	500	
Story1	B19	53	Beam	6000	Girder	Girder	500	
Story1	B42	95	Beam	6000	Sub-beam	Sub-beam	500	
Story1	B43	96	Beam	6000	Sub-beam	Sub-beam	500	
Story1	B44	97	Beam	6000	Sub-beam	Sub-beam	500	
Story1	B45	98	Beam	6000	Sub-beam	Sub-beam	500	
Story1	B46	99	Beam	6000	Sub-beam	Sub-beam	500	
Story1	B47	100	Beam	6000	Sub-beam	Sub-beam	500	
Story1	B48	101	Beam	6000	Sub-beam	Sub-beam	500	
Story1	B49	102	Beam	6000	Sub-beam	Sub-beam	500	
Story1	B50	103	Beam	6000	Sub-beam	Sub-beam	500	

Story	Label	Unique Name	Design Type	Length mm	Analysis Section	Design Section	Max Station Spacing mm	Min Number Stations
Story1	B51	104	Beam	6000	Sub-beam	Sub-beam	500	
Story1	B52	105	Beam	6000	Sub-beam	Sub-beam	500	
Story1	B53	106	Beam	6000	Sub-beam	Sub-beam	500	
Story1	B36	27	Beam	9000	Girder	Girder	500	
Story1	B40	113	Beam	9000	Girder	Girder	500	
Story1	B5	28	Beam	6000	Girder	Girder	500	
Story1	B60	130	Beam	9000	Girder	Girder	500	
Story1	B62	135	Beam	9000	Girder	Girder	500	
Story1	B63	133	Beam	6000	Girder	Girder	500	

2.6.4 Loads

This chapter provides loading information as applied to the model.

a) Load Patterns

Load Patterns

Name	Type	Self-Weight Multiplier
Dead	Dead	1
Live	Live	0

b) Applied Loads

Frame Loads - Point

Story	Label	Unique Name	Design Type	Load Pattern	Load Type	Direction	Relative Distance	Absolute Distance mm	Force kN
Story2	B17	70	Beam	Dead	Force	Gravity	0.5	3000	61.5
Story2	B21	74	Beam	Dead	Force	Gravity	0.5	3000	61.5
Story2	B24	77	Beam	Dead	Force	Gravity	0.5	3000	61.5
Story2	B25	78	Beam	Dead	Force	Gravity	0.5	3000	61.5

Frame Loads - Distributed

Story	Label	Unique Name	Design Type	Load Pattern	Load Type	Direction	Relative Distance Start	Relative Distance End	Absolute Distance Start mm	Absolute Distance End mm	Force at Start kN/m	Force at End kN/m
Story2	B1	54	Beam	Dead	Force	Gravity	0	1	0	6000	9.197	9.197
Story2	B2	55	Beam	Dead	Force	Gravity	0	1	0	6000	9.197	9.197
Story2	B3	56	Beam	Dead	Force	Gravity	0	1	0	6000	9.197	9.197
Story2	B4	57	Beam	Dead	Force	Gravity	0	1	0	6000	9.197	9.197
Story2	B7	60	Beam	Dead	Force	Gravity	0	1	0	6000	9.197	9.197
Story2	B8	61	Beam	Dead	Force	Gravity	0	1	0	6000	9.197	9.197
Story2	B9	62	Beam	Dead	Force	Gravity	0	1	0	6000	9.197	9.197
Story2	B10	63	Beam	Dead	Force	Gravity	0	1	0	6000	9.197	9.197
Story2	B13	66	Beam	Dead	Force	Gravity	0	1	0	6000	18.394	18.394
Story2	B19	72	Beam	Dead	Force	Gravity	0	1	0	6000	18.394	18.394
Story2	B23	76	Beam	Dead	Force	Gravity	0	1	0	6000	18.394	18.394
Story2	B24	77	Beam	Dead	Force	Gravity	0	1	0	6000	9.197	9.197
Story2	B25	78	Beam	Dead	Force	Gravity	0	1	0	6000	9.197	9.197

Story	Label	Unique Name	Design Type	Load Pattern	Load Type	Direction	Relative Distance Start	Relative Distance End	Absolute Distance Start mm	Absolute Distance End mm	Force at Start kN/m	Force at End kN/m
Story2	B42	45	Beam	Dead	Force	Gravity	0	1	0	6000	18.394	18.394
Story2	B43	46	Beam	Dead	Force	Gravity	0	1	0	6000	18.394	18.394
Story2	B44	48	Beam	Dead	Force	Gravity	0	1	0	6000	18.394	18.394
Story2	B45	49	Beam	Dead	Force	Gravity	0	1	0	6000	18.394	18.394
Story2	B46	80	Beam	Dead	Force	Gravity	0	1	0	6000	18.394	18.394
Story2	B47	81	Beam	Dead	Force	Gravity	0	1	0	6000	18.394	18.394
Story2	B48	82	Beam	Dead	Force	Gravity	0	1	0	6000	18.394	18.394
Story2	B49	84	Beam	Dead	Force	Gravity	0	1	0	6000	18.394	18.394
Story2	B50	85	Beam	Dead	Force	Gravity	0	1	0	6000	18.394	18.394
Story2	B51	86	Beam	Dead	Force	Gravity	0	1	0	6000	18.394	18.394
Story2	B52	88	Beam	Dead	Force	Gravity	0	1	0	6000	18.394	18.394
Story2	B53	89	Beam	Dead	Force	Gravity	0	1	0	6000	18.394	18.394
Story2	B26	90	Beam	Dead	Force	Gravity	0	1	0	6000	18.394	18.394
Story2	B27	92	Beam	Dead	Force	Gravity	0	1	0	6000	18.394	18.394
Story2	B28	93	Beam	Dead	Force	Gravity	0	1	0	6000	18.394	18.394
Story2	B29	94	Beam	Dead	Force	Gravity	0	1	0	6000	18.394	18.394
Story2	B30	107	Beam	Dead	Force	Gravity	0	1	0	6000	18.394	18.394
Story2	B31	108	Beam	Dead	Force	Gravity	0	1	0	6000	18.394	18.394
Story2	B32	109	Beam	Dead	Force	Gravity	0	1	0	6000	18.394	18.394
Story2	B33	110	Beam	Dead	Force	Gravity	0	1	0	6000	18.394	18.394
Story2	B34	111	Beam	Dead	Force	Gravity	0	1	0	6000	18.394	18.394
Story2	B35	112	Beam	Dead	Force	Gravity	0	1	0	6000	18.394	18.394
Story1	B1	21	Beam	Dead	Force	Gravity	0	1	0	6000	11.004	11.004
Story1	B2	22	Beam	Dead	Force	Gravity	0	1	0	6000	11.004	11.004
Story1	B3	37	Beam	Dead	Force	Gravity	0	1	0	6000	0.5	0.5
Story1	B4	38	Beam	Dead	Force	Gravity	0	1	0	6000	0.5	0.5
Story1	B7	41	Beam	Dead	Force	Gravity	0	1	0	6000	0.5	0.5
Story1	B8	42	Beam	Dead	Force	Gravity	0	1	0	6000	0.5	0.5
Story1	B9	43	Beam	Dead	Force	Gravity	0	1	0	6000	11.004	11.004
Story1	B10	44	Beam	Dead	Force	Gravity	0	1	0	6000	11.004	11.004
Story1	B13	47	Beam	Dead	Force	Gravity	0	1	0	6000	20.509	20.509
Story1	B16	50	Beam	Dead	Force	Gravity	0	1	0	9000	0.5	0.5
Story1	B17	51	Beam	Dead	Force	Gravity	0	1	0	6000	0.5	0.5
Story1	B18	52	Beam	Dead	Force	Gravity	0	1	0	9000	0.5	0.5
Story1	B19	53	Beam	Dead	Force	Gravity	0	1	0	6000	20.509	20.509
Story1	B42	95	Beam	Dead	Force	Gravity	0	1	0	6000	20.509	20.509
Story1	B43	96	Beam	Dead	Force	Gravity	0	1	0	6000	20.509	20.509
Story1	B44	97	Beam	Dead	Force	Gravity	0	1	0	6000	20.509	20.509
Story1	B45	98	Beam	Dead	Force	Gravity	0	1	0	6000	20.509	20.509

Story	Label	Unique Name	Design Type	Load Pattern	Load Type	Direction	Relative Distance Start	Relative Distance End	Absolute Distance Start mm	Absolute Distance End mm	Force at Start kN/m	Force at End kN/m
Story1	B46	99	Beam	Dead	Force	Gravity	0	1	0	6000	20.509	20.509
Story1	B47	100	Beam	Dead	Force	Gravity	0	1	0	6000	20.509	20.509
Story1	B48	101	Beam	Dead	Force	Gravity	0	1	0	6000	20.509	20.509
Story1	B49	102	Beam	Dead	Force	Gravity	0	1	0	6000	20.509	20.509
Story1	B50	103	Beam	Dead	Force	Gravity	0	1	0	6000	20.509	20.509
Story1	B51	104	Beam	Dead	Force	Gravity	0	1	0	6000	20.509	20.509
Story1	B52	105	Beam	Dead	Force	Gravity	0	1	0	6000	20.509	20.509
Story1	B53	106	Beam	Dead	Force	Gravity	0	1	0	6000	20.509	20.509
Story1	B60	130	Beam	Dead	Force	Gravity	0	0.333333	0	3000	0.5	0.5
Story1	B60	130	Beam	Dead	Force	Gravity	0.333333	0.666667	3000	6000	0.5	0.5
Story1	B60	130	Beam	Dead	Force	Gravity	0.666667	1	6000	9000	0.5	0.5
Story1	B62	135	Beam	Dead	Force	Gravity	0	0.333333	0	3000	0.5	0.5
Story1	B62	135	Beam	Dead	Force	Gravity	0.333333	0.666667	3000	6000	0.5	0.5
Story1	B62	135	Beam	Dead	Force	Gravity	0.666667	1	6000	9000	0.5	0.5
Story1	B63	133	Beam	Dead	Force	Gravity	0	0.5	0	3000	0.5	0.5
Story1	B63	133	Beam	Dead	Force	Gravity	0.5	1	3000	6000	0.5	0.5
Story2	B1	54	Beam	Live	Force	Gravity	0	1	0	6000	3.75	3.75
Story2	B2	55	Beam	Live	Force	Gravity	0	1	0	6000	3.75	3.75
Story2	B3	56	Beam	Live	Force	Gravity	0	1	0	6000	3.75	3.75
Story2	B4	57	Beam	Live	Force	Gravity	0	1	0	6000	3.75	3.75
Story2	B7	60	Beam	Live	Force	Gravity	0	1	0	6000	3.75	3.75
Story2	B8	61	Beam	Live	Force	Gravity	0	1	0	6000	3.75	3.75
Story2	B9	62	Beam	Live	Force	Gravity	0	1	0	6000	3.75	3.75
Story2	B10	63	Beam	Live	Force	Gravity	0	1	0	6000	3.75	3.75
Story2	B13	66	Beam	Live	Force	Gravity	0	1	0	6000	7.5	7.5
Story2	B17	70	Beam	Live	Force	Gravity	0	1	0	6000	7.5	7.5
Story2	B19	72	Beam	Live	Force	Gravity	0	1	0	6000	7.5	7.5
Story2	B21	74	Beam	Live	Force	Gravity	0	1	0	6000	7.5	7.5
Story2	B23	76	Beam	Live	Force	Gravity	0	1	0	6000	7.5	7.5
Story2	B24	77	Beam	Live	Force	Gravity	0	1	0	6000	3.75	3.75
Story2	B25	78	Beam	Live	Force	Gravity	0	1	0	6000	3.75	3.75
Story2	B42	45	Beam	Live	Force	Gravity	0	1	0	6000	7.5	7.5
Story2	B43	46	Beam	Live	Force	Gravity	0	1	0	6000	7.5	7.5

Story	Label	Unique Name	Design Type	Load Pattern	Load Type	Direction	Relative Distance Start	Relative Distance End	Absolute Distance Start mm	Absolute Distance End mm	Force at Start kN/m	Force at End kN/m
Story2	B44	48	Beam	Live	Force	Gravity	0	1	0	6000	7.5	7.5
Story2	B45	49	Beam	Live	Force	Gravity	0	1	0	6000	7.5	7.5
Story2	B46	80	Beam	Live	Force	Gravity	0	1	0	6000	7.5	7.5
Story2	B47	81	Beam	Live	Force	Gravity	0	1	0	6000	7.5	7.5
Story2	B48	82	Beam	Live	Force	Gravity	0	1	0	6000	7.5	7.5
Story2	B49	84	Beam	Live	Force	Gravity	0	1	0	6000	7.5	7.5
Story2	B50	85	Beam	Live	Force	Gravity	0	1	0	6000	7.5	7.5
Story2	B51	86	Beam	Live	Force	Gravity	0	1	0	6000	7.5	7.5
Story2	B52	88	Beam	Live	Force	Gravity	0	1	0	6000	7.5	7.5
Story2	B53	89	Beam	Live	Force	Gravity	0	1	0	6000	7.5	7.5
Story2	B26	90	Beam	Live	Force	Gravity	0	1	0	6000	7.5	7.5
Story2	B27	92	Beam	Live	Force	Gravity	0	1	0	6000	7.5	7.5
Story2	B28	93	Beam	Live	Force	Gravity	0	1	0	6000	7.5	7.5
Story2	B29	94	Beam	Live	Force	Gravity	0	1	0	6000	7.5	7.5
Story2	B30	107	Beam	Live	Force	Gravity	0	1	0	6000	7.5	7.5
Story2	B31	108	Beam	Live	Force	Gravity	0	1	0	6000	7.5	7.5
Story2	B32	109	Beam	Live	Force	Gravity	0	1	0	6000	7.5	7.5
Story2	B33	110	Beam	Live	Force	Gravity	0	1	0	6000	7.5	7.5
Story2	B34	111	Beam	Live	Force	Gravity	0	1	0	6000	7.5	7.5
Story2	B35	112	Beam	Live	Force	Gravity	0	1	0	6000	7.5	7.5
Story1	B1	21	Beam	Live	Force	Gravity	0	1	0	6000	7.5	7.5
Story1	B2	22	Beam	Live	Force	Gravity	0	1	0	6000	7.5	7.5
Story1	B9	43	Beam	Live	Force	Gravity	0	1	0	6000	7.5	7.5
Story1	B10	44	Beam	Live	Force	Gravity	0	1	0	6000	7.5	7.5
Story1	B13	47	Beam	Live	Force	Gravity	0	1	0	6000	15	15
Story1	B19	53	Beam	Live	Force	Gravity	0	1	0	6000	15	15
Story1	B42	95	Beam	Live	Force	Gravity	0	1	0	6000	15	15
Story1	B43	96	Beam	Live	Force	Gravity	0	1	0	6000	15	15
Story1	B44	97	Beam	Live	Force	Gravity	0	1	0	6000	15	15
Story1	B45	98	Beam	Live	Force	Gravity	0	1	0	6000	15	15
Story1	B46	99	Beam	Live	Force	Gravity	0	1	0	6000	15	15
Story1	B47	100	Beam	Live	Force	Gravity	0	1	0	6000	15	15
Story1	B48	101	Beam	Live	Force	Gravity	0	1	0	6000	15	15
Story1	B49	102	Beam	Live	Force	Gravity	0	1	0	6000	15	15
Story1	B50	103	Beam	Live	Force	Gravity	0	1	0	6000	15	15
Story1	B51	104	Beam	Live	Force	Gravity	0	1	0	6000	15	15
Story1	B52	105	Beam	Live	Force	Gravity	0	1	0	6000	15	15
Story1	B53	106	Beam	Live	Force	Gravity	0	1	0	6000	15	15

c) Load Cases

Load Cases - Summary

Name	Type
Dead	Linear Static
Live	Linear Static

d) Load Combinations

Load Combinations

Name	Load Case/Comb	Scale Factor	Type	Auto
dead+live 2015	Dead	1.2	Linear Add	No
dead+live 2015	Live	1.6		No
DCon1	Dead	1.4	Linear Add	Yes
DCon2	Dead	1.2	Linear Add	Yes
DCon2	Live	1.6		No

Appendix B: Steel design and modeling using ETABS 2015

LIVE LOADS

**TABLE 4-1:
MINIMUM UNIFORMLY DISTRIBUTED LIVE LOADS, L_u ,
AND MINIMUM CONCENTRATED LIVE LOADS**

Occupancy or Use	Uniform kN/m ²	Conc. kN
Apartments (see residential)		
Access floor systems		
Office use	2.5	9
Computer use	5	9
Armories and drill rooms	7.5	
Assembly areas and theaters		
• Fixed seats (fastened to floor)	3	
• Lobbies	5	
• Movable seats	5	
• Platforms (assembly)	5	
• Stage floors	7.5	
Balconies (exterior)	5	
On one- and two-family residences only, and not exceeding 10 m ²	3	
Bowling alleys, poolrooms, and similar recreational areas	4	
Catwalks for maintenance access	2	1.5
Corridors		
First floor	5	
Other floors, same as occupancy served except as indicated		
Mosques	5	
Decks (patio and roof)		
Same as area served, or for the type of occupancy accommodated		
Dining rooms and restaurants	5	
Dwellings (see residential)		
Elevator machine room grating (on area of 2500 mm ²)		1.5
Finish light floor plate construction (on area of 650 mm ²)		1
Fire escapes	5	
Fixed ladders	See Section 4.4	
Garages (passenger vehicles only)	2	Note (1)
Trucks and buses	Note (2)	Note (2)
Grandstands (see stadium and arena bleachers)		
Gymnasiums, main floors, and balconies	5 Note (4)	
Handrails, guardrails, and grab bars	See Section 4.4	
Hospitals		
• Operating rooms, laboratories	3	4.5
• Private rooms	2	4.5
• Wards	2	4.5
• Corridors above first floor	4	4.5
Hotels (see residential)		
Libraries		
• Reading rooms	3	4.5
• Stack rooms	7.5 Note (3)	4.5
• Corridors above first floor	4	4.5
Manufacturing		
• Light	6	9
• Heavy	12	13.5
Marquees and canopies	4	
Office buildings		
• File and computer rooms shall be designed for heavier loads based on anticipated occupancy:		
• Lobbies and first floor corridors	5	9
• Offices	2.5	9
• Corridors above first floor	4.0	9
Penal institutions		
Cell blocks	2	
Corridors	5	

Table 3-23 (continued)
Shears, Moments, and Deflections

15. BEAM FIXED AT BOTH ENDS — UNIFORMLY DISTRIBUTED LOADS

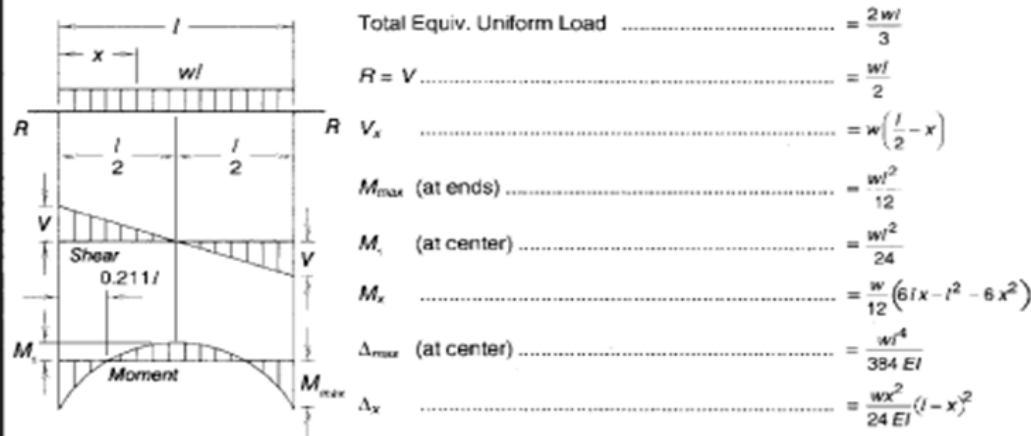

16. BEAM FIXED AT BOTH ENDS — CONCENTRATED LOAD AT CENTER

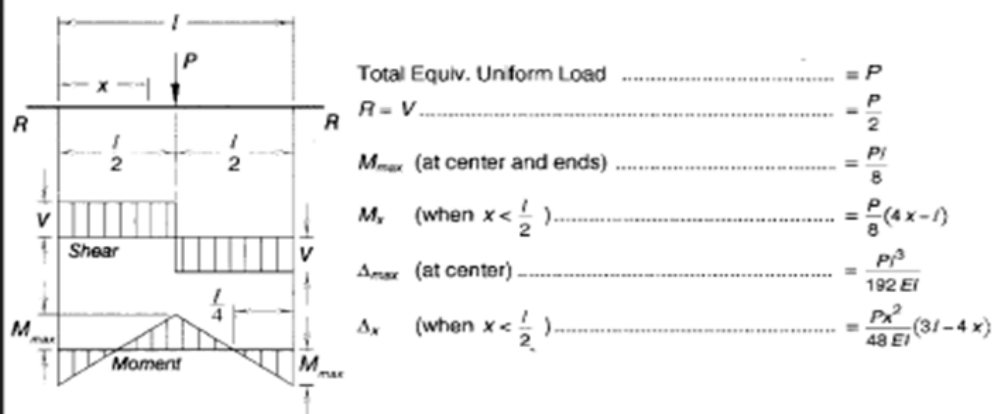

17. BEAM FIXED AT BOTH ENDS — CONCENTRATED LOAD AT ANY POINT

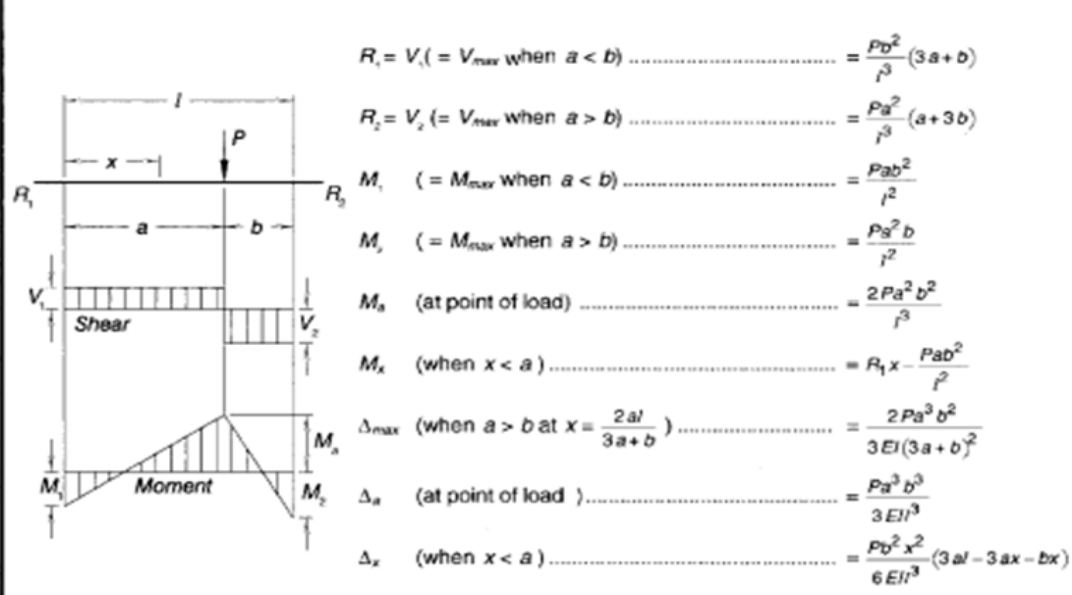

Material Property Design Data

Material Name and Type

Material Name: A992Fy50

Material Type: Steel, Isotropic

Design Properties for Steel Materials

Minimum Yield Stress, Fy	35153.48	tonf/m ²
Minimum Tensile Strength, Fu	45699.53	tonf/m ²
Effective Yield Stress, Fye	38668.83	tonf/m ²
Effective Tensile Strength, Fue	50269.48	tonf/m ²

Material Property Data

General Data

Material Name: A992Fy50

Material Type: Steel

Directional Symmetry Type: Isotropic

Material Display Color: Change...

Material Notes: Modify/Show Notes...

Material Weight and Mass

Specify Weight Density Specify Mass Density

Weight per Unit Volume: 7.849 tonf/m³

Mass per Unit Volume: 0.80038 tonf-s²/m⁴

Mechanical Property Data

Modulus of Elasticity, E	20389019.16	tonf/m ²
Poisson's Ratio, U	0.3	
Coefficient of Thermal Expansion, A	0.0000117	1/C
Shear Modulus, G	7841930.45	tonf/m ²

Property Name

Section Name

Base Material

Properties

Item	Value
Area, m2	0.0239
AS2, m2	0.0073
AS3, m2	0.014
I33, m4	0.001072
I22, m4	0.000126
S33Pos, m3	0.004288
S33Neg, m3	0.004288
S22Pos, m3	0.000841
S22Neg, m3	0.000841
R33, m	0.21179
R22, m	0.07267
Z33, m3	0.004815
Z22, m3	0.001292
J, m4	0.000005
Cw, m6	7.018E-06
Fillet Radius, m	0.027
CG Offset 3 Dir, m	0
CG Offset 2 Dir, m	0
PNA Offset 3 Dir, m	0
PNA Offset 2 Dir, m	0

OK

Cancel

EUROPEAN SPECIFICATION BEAMS WITH
PARALLEL FLANGES IN ACCORDANCE
WITH EURONORM 19-57



Designation	G	h	b	t _w	t _f	r	A	h ₁	d
	kg/m	mm	mm	mm	mm	mm	cm ²	mm	mm
IPE 270 A	30.7	267	135	5.5	8.7	15	39.1	249.6	219.6
IPE 270	36.1	270	135	6.6	10.2	15	45.9	249.6	219.6
IPE 270 O	42.3	274	136	7.5	12.2	15	53.8	249.6	219.6
IPE 270 R	44.0	276	133	7.7	13.1	15	56.0	249.8	219.8
IPE 300 A	36.5	297	150	6.1	9.2	15	46.5	278.6	248.6
IPE 300	42.2	300	150	7.1	10.7	15	53.8	278.6	248.6
IPE 300 O	49.3	304	152	8.0	12.7	15	62.8	278.6	248.6
IPE 300 R	51.7	306	147	8.5	13.7	15	65.9	278.6	248.6
IPE 330 A	43.0	327	160	6.5	10.0	18	54.7	307.0	271.0
IPE 330	49.1	330	160	7.5	11.5	18	62.6	307.0	271.0
IPE 330 O	57.0	334	162	8.5	13.5	18	72.6	307.0	271.0
IPE 330 R	60.3	336	158	9.2	14.5	18	76.8	307.0	271.0
IPE 360 A	50.2	357.6	170	6.6	11.5	18	64.0	334.6	298.6
IPE 360	57.1	360	170	8.0	12.7	18	72.7	334.6	298.6
IPE 360 O	66.0	364	172	9.2	14.7	18	84.1	334.6	298.6
IPE 360 R	70.3	366	168	9.9	16.0	18	89.6	334.0	298.0
IPE 400 A	57.4	397	180	7.0	12.0	21	73.1	373.0	331.0
IPE 400	66.3	400	180	8.6	13.5	21	84.5	373.0	331.0
IPE 400 O	75.7	404	182	9.7	15.5	21	96.4	373.0	331.0
IPE 400 R	81.5	407	178	10.6	17.0	21	104	373.0	331.0
IPE 400 V	84.0	408	182	10.6	17.5	21	107	373.0	331.0
IPE 450 A	67.2	447	190	7.6	13.1	21	85.5	420.8	378.8
IPE 450	77.6	450	190	9.4	14.6	21	98.8	420.8	378.8
IPE 450 O	92.4	456	192	11.0	17.6	21	118	420.8	378.8
IPE 450 R	95.2	458	188	11.3	18.6	21	121	420.8	378.8
IPE 450 V	104	460	194	12.4	19.6	21	132	420.8	378.8

EUROPEAN SPECIFICATION BEAMS WITH
PARALLEL FLANGES IN ACCORDANCE
WITH EURONORM 19-57



l _y	l _z	i _y	i _z	W _y	W _z	W _{ply}	W _{plz}	I _w	IT
cm ⁴	cm ⁴	cm	cm	cm ³	cm ³	cm ³	cm ³	dm ⁴	cm ⁴
4917	358	11.2	3.02	368	53.0	412	82.3	0.060	10.4
5790	420	11.2	3.02	429	62.2	484	97.0	0.071	15.9
6947	513	11.4	3.09	507	75.5	575	118	0.088	25.0
7312	516	11.4	3.03	530	77.6	602	121	0.089	29.1
7173	519	12.4	3.34	483	69.2	542	107	0.107	13.3
8356	604	12.5	3.35	557	80.5	628	125	0.126	19.9
9994	746	12.6	3.45	658	98.1	744	153	0.158	31.0
10500	728	12.6	3.32	686	99.0	780	155	0.155	37.0
10230	685	13.7	3.54	626	85.6	702	133	0.172	19.6
11770	788	13.7	3.55	713	98.5	804	154	0.200	28.1
13910	960	13.8	3.64	833	119	943	185	0.247	42.2
14690	958	13.8	3.53	874	121	995	190	0.247	50.6
14520	944	15.1	3.84	812	111	907	172	0.283	27.4
16270	1043	15.0	3.79	904	123	1019	191	0.315	37.4
19050	1251	15.0	3.86	1047	145	1186	227	0.382	55.7
20290	1270	15.0	3.76	1109	151	1262	236	0.389	68.7
20290	1171	16.7	4.00	1022	130	1144	202	0.434	36.2
23130	1318	16.5	3.95	1156	146	1307	229	0.492	51.3
26750	1564	16.7	4.03	1324	172	1502	269	0.590	73.3
28860	1606	16.7	3.93	1418	180	1618	284	0.611	92.5
30140	1766	16.8	4.06	1477	194	1681	304	0.673	99.6
29760	1502	18.7	4.19	1331	158	1494	246	0.707	47.1
33740	1676	18.5	4.12	1500	176	1702	276	0.794	66.7
40920	2085	18.6	4.21	1795	217	2046	341	1.00	109
42400	2070	18.7	4.13	1851	220	2115	346	0.999	123
46200	2397	18.7	4.26	2009	247	2301	389	1.16	149

**EUROPEAN SPECIFICATION BEAMS WITH
PARALLEL FLANGES IN ACCORDANCE
WITH EURONORM 53-62**



Designation	G	h	b	t _w	t _f	r	A	h ₁	d
	kg/m	mm	mm	mm	mm	mm	cm ²	mm	mm
HE 280 AA	61.2	264	280	7.0	10.0	24	78	244	196
HE 280 A	76.4	270	280	8.0	13.0	24	97.3	244	196
HE 280 B	103	280	280	10.5	18.0	24	131	244	196
HE 280 M	189	310	288	18.5	33.0	24	240	244	196
HE 300 AA	69.8	283	300	7.5	10.5	27	88.9	262	208
HE 300 A	88.3	290	300	8.5	14.0	27	113	262	208
HE 300 B	117	300	300	11.0	19.0	27	149	262	208
HE 300 C	177	320	305	16.0	29.0	27	225	262	208
HE 300 M	238	340	310	21.0	39.0	27	303	262	208
HE 320 AA	74.2	301	300	8.0	11.0	27	94.6	279	225
HE 320 A	97.6	310	300	9.0	15.5	27	124	279	225
HE 320 B	127	320	300	11.5	20.5	27	161	279	225
HE 320 M	245	359	309	21.0	40.0	27	312	279	225
HE 340 AA	78.9	320	300	8.5	11.5	27	101	297	243
HE 340 A	105	330	300	9.5	16.5	27	133	297	243
HE 340 B	134	340	300	12.0	21.5	27	171	297	243
HE 340 M	248	377	309	21.0	40.0	27	316	297	243
HE 360 AA	83.7	339	300	9.0	12.0	27	107	315	261
HE 360 A	112	350	300	10.0	17.5	27	143	315	261
HE 360 B	142	360	300	12.5	22.5	27	181	315	261
HE 360 M	250	395	308	21.0	40.0	27	319	315	261
HE 400 AA	92.4	378	300	9.5	13.0	27	118	352	298
HE 400 x 107	107	384	297	10.0	16.0	27	136	352	298
HE 400 A	125	390	300	11.0	19.0	27	159	352	298
HE 400 B	155	400	300	13.5	24.0	27	198	352	298
HE 400 M	256	432	307	21.0	40.0	27	326	352	298
HE 450 AA	100	425	300	10.0	13.5	27	127	398	344
HE 450 x 123	123	435	300	10.2	18.5	27	158	398	344
HE 450 A	140	440	300	11.5	21.0	27	178	398	344
HE 450 B	171	450	300	14.0	26.0	27	218	398	344
HE 450 M	263	478	307	21.0	40.0	27	335	398	344
HE 500 AA	107	472	300	10.5	14.0	27	137	444	390
HE 500 A	155	490	300	12.0	23.0	27	198	444	390
HE 500 B	187	500	300	14.5	28.0	27	239	444	390
HE 500 M	270	524	306	21.0	40.0	27	344	444	390

**EUROPEAN SPECIFICATION BEAMS WITH
PARALLEL FLANGES IN ACCORDANCE
WITH EURONORM 53-62**



l _y	l _z	I _y	I _z	W _y	W _z	W _{pl,y}	W _{pl,z}	I _w	I _r
cm ⁴	cm ⁴	cm ⁴	cm ⁴	cm ³	cm ³	cm ³	cm ³	dm ⁶	cm ⁴
10560	3664	11.6	6.85	800	262	873	399	0.591	35.5
13670	4763	11.9	7.00	1013	340	1112	518	0.786	63.5
19270	6595	12.1	7.09	1376	471	1534	718	1.13	146
39550	13160	12.8	7.40	2551	914	2966	1397	2.52	807
13800	4734	12.5	7.30	976	316	1065	482	0.879	47.8
18260	6310	12.7	7.49	1260	421	1383	641	1.20	87.8
25170	8563	13.0	7.58	1678	571	1869	870	1.69	189
40950	13740	13.5	7.80	2559	901	2927	1374	2.91	604
59200	19400	14.0	8.00	3482	1252	4078	1913	4.39	1411
16450	4959	13.2	7.24	1093	331	1196	506	1.04	53.6
22930	6985	13.6	7.49	1479	466	1628	710	1.51	112
30820	9239	13.8	7.57	1926	616	2149	939	2.07	230
68130	19710	14.8	7.95	3796	1276	4435	1951	5.01	1506
19550	5185	13.9	7.18	1222	346	1341	529	1.23	60.0
27690	7436	14.4	7.46	1678	496	1850	756	1.83	131
36660	9690	14.6	7.53	2156	646	2408	986	2.46	263
76370	19710	15.6	7.90	4052	1276	4718	1953	5.60	1512
23040	5410	14.7	7.12	1359	361	1495	553	1.45	67.1
33090	7887	15.2	7.43	1891	526	2088	802	2.18	153
43190	10140	15.5	7.49	2400	676	2683	1032	2.89	298
84870	19520	16.3	7.83	4297	1268	4989	1942	6.15	1513
31250	5861	16.3	7.06	1654	391	1824	600	1.95	81.3
37640	6998	16.6	7.20	1960	471	2165	721	2.37	126
45070	8564	16.8	7.34	2311	571	2562	873	2.95	193
57680	10820	17.1	7.40	2884	721	3232	1104	3.82	361
104100	19340	17.9	7.70	4820	1260	5571	1934	7.43	1520
41890	6088	18.2	6.92	1971	406	2183	624	2.58	91.4
55860	8338	18.8	7.27	2568	556	2836	850	3.62	178
63720	9465	18.9	7.29	2896	631	3216	966	4.15	250
79890	11720	19.1	7.33	3551	781	3982	1198	5.27	448
131500	19340	19.8	7.59	5501	1260	6331	1939	9.28	1534
54640	6314	20.0	6.79	2315	421	2576	649	3.31	103
86970	10370	21.0	7.24	3550	691	3949	1059	5.65	318
107200	12620	21.2	7.27	4287	842	4815	1292	7.03	548
161900	19150	21.7	7.46	6180	1252	7094	1932	11.2	1544

C_b is permitted to be conservatively taken as 1.0 for all cases. For cantilevers or overhangs where the free end is unbraced, $C_b = 1.0$.

User Note: For doubly symmetric members with no transverse loading between brace points, Equation F1-1 reduces to 2.27 for the case of equal end moments of opposite sign and to 1.67 when one end moment equals zero.

F2. DOUBLY SYMMETRIC COMPACT I-SHAPED MEMBERS AND CHANNELS BENT ABOUT THEIR MAJOR AXIS

This section applies to doubly symmetric I-shaped members and channels bent about their major axis, having compact webs and compact flanges as defined in Section B4.

User Note: All current ASTM A6 W, S, M, C and MC shapes except W21×48, W14×99, W14×90, W12×65, W10×12, W8×31, W8×10, W6×15, W6×9, W6×8.5, and M4×6 have compact flanges for $F_y = 50$ ksi (345 MPa); all current ASTM A6 W, S, M, HP, C and MC shapes have compact webs at $F_y \leq 65$ ksi (450 MPa).

The *nominal flexural strength*, M_n , shall be the lower value obtained according to the *limit states* of yielding (*plastic moment*) and *lateral-torsional buckling*.

1. Yielding

$$M_n = M_p = F_y Z_x \quad (\text{F2-1})$$

where

F_y = specified minimum yield stress of the type of steel being used, ksi (MPa)
 Z_x = plastic section modulus about the x-axis, in.³ (mm³)

2. Lateral-Torsional Buckling

(a) When $L_b \leq L_p$, the limit state of lateral-torsional buckling does not apply.

(b) When $L_p < L_b \leq L_r$

$$M_n = C_b \left[M_p - (M_p - 0.7F_y S_x) \left(\frac{L_b - L_p}{L_r - L_p} \right) \right] \leq M_p \quad (\text{F2-2})$$

(c) When $L_b > L_r$

$$M_n = F_{cr} S_x \leq M_p \quad (\text{F2-3})$$

where

L_b = length between points that are either braced against lateral displacement of compression flange or braced against twist of the cross section, in. (mm)

$$F_{cr} = \frac{C_b \pi^2 E}{\left(\frac{L_b}{r_{ts}} \right)^2} \sqrt{1 + 0.078 \frac{J_C}{S_x h_o} \left(\frac{L_b}{r_{ts}} \right)^2} \quad (\text{F2-4})$$

Specification for Structural Steel Buildings, March 9, 2005
 AMERICAN INSTITUTE OF STEEL CONSTRUCTION, INC.

and where

E = modulus of elasticity of steel = 29,000 ksi (200 000 MPa)

J = torsional constant, in.⁴ (mm⁴)

S_x = elastic section modulus taken about the x-axis, in.³ (mm³)

User Note: The square root term in Equation F2-4 may be conservatively taken equal to 1.0.

The limiting lengths L_p and L_r are determined as follows:

$$L_p = 1.76r_y \sqrt{\frac{E}{F_y}} \quad (\text{F2-5})$$

$$L_r = 1.95r_{ts} \frac{E}{0.7F_y} \sqrt{\frac{Jc}{S_x h_o}} \sqrt{1 + \sqrt{1 + 6.76 \left(\frac{0.7F_y}{E} \frac{S_x h_o}{Jc} \right)^2}} \quad (\text{F2-6})$$

where

$$r_{ts}^2 = \frac{\sqrt{I_y C_w}}{S_x} \quad (\text{F2-7})$$

and

$$\text{For a doubly symmetric I-shape: } c = 1 \quad (\text{F2-8a})$$

$$\text{For a channel: } c = \frac{h_o}{2} \sqrt{\frac{I_y}{C_w}} \quad (\text{F2-8b})$$

where

h_o = distance between the flange centroids, in. (mm)

User Note: If the square root term in Equation F2-4 is conservatively taken equal to 1, Equation F2-6 becomes

$$L_r = \pi r_{ts} \sqrt{\frac{E}{0.7F_y}}$$

Note that this approximation can be extremely conservative.

For doubly symmetric I-shapes with rectangular flanges, $C_w = \frac{I_y h_o^2}{4}$ and thus Equation F2-7 becomes

$$r_{ts}^2 = \frac{I_y h_o}{2S_x}$$

r_{ts} may be approximated accurately and conservatively as the radius of gyration of the compression flange plus one-sixth of the web:

$$r_{ts} = \frac{b_f}{\sqrt{12 \left(1 + \frac{1}{6} \frac{h t_w}{b_f t_f} \right)}}$$

CHAPTER G

DESIGN OF MEMBERS FOR SHEAR

This chapter addresses webs of singly or doubly symmetric members subject to shear in the plane of the web, single angles and *HSS* sections, and shear in the weak direction of singly or doubly symmetric shapes.

The chapter is organized as follows:

- G1. General Provisions
- G2. Members with Unstiffened or Stiffened Webs
- G3. Tension Field Action
- G4. Single Angles
- G5. Rectangular *HSS* and Box Members
- G6. Round *HSS*
- G7. Weak Axis Shear in Singly and Doubly Symmetric Shapes
- G8. Beams and Girders with Web Openings

User Note: For applications not included in this chapter, the following sections apply:

- H3.3 Unsymmetric sections.
- J4.2 Shear strength of connecting elements.
- J10.6 Web panel zone shear.

G1. GENERAL PROVISIONS

Two methods of calculating shear strength are presented below. The method presented in Section G2 does not utilize the post *buckling strength* of the member (*tension field action*). The method presented in Section G3 utilizes tension field action.

The *design shear strength*, $\phi_v V_n$, and the *allowable shear strength*, V_n/Ω_v , shall be determined as follows.

For all provisions in this chapter except Section G2.1a:

$$\phi_v = 0.90 \text{ (LRFD)} \quad \Omega_v = 1.67 \text{ (ASD)}$$

G2. MEMBERS WITH UNSTIFFENED OR STIFFENED WEBS

1. Nominal Shear Strength

This section applies to webs of singly or doubly symmetric members and channels subject to shear in the plane of the web.

Specification for Structural Steel Buildings, March 9, 2005
AMERICAN INSTITUTE OF STEEL CONSTRUCTION, INC.

The *nominal shear strength*, V_n , of unstiffened or stiffened webs, according to the *limit states of shear yielding and shear buckling*, is

$$V_n = 0.6F_y A_w C_v \quad (\text{G2-1})$$

(a) For webs of rolled I-shaped members with $h/t_w \leq 2.24\sqrt{E/F_y}$:

$$\phi_v = 1.00 \text{ (LRFD)} \quad \Omega_v = 1.50 \text{ (ASD)}$$

and

$$C_v = 1.0 \quad (\text{G2-2})$$

User Note: All current ASTM A6 W, S and HP shapes except W44×230, W40×149, W36×135, W33×118, W30×90, W24×55, W16×26 and W12×14 meet the criteria stated in Section G2.1(a) for $F_y = 50$ ksi (345 MPa).

(b) For webs of all other doubly symmetric shapes and singly symmetric shapes and channels, except round *HSS*, the web shear coefficient, C_v , is determined as follows:

(i) For $h/t_w \leq 1.10\sqrt{k_v E/F_y}$

$$C_v = 1.0 \quad (\text{G2-3})$$

(ii) For $1.10\sqrt{k_v E/F_y} < h/t_w \leq 1.37\sqrt{k_v E/F_y}$

$$C_v = \frac{1.10\sqrt{k_v E/F_y}}{h/t_w} \quad (\text{G2-4})$$

(iii) For $h/t_w > 1.37\sqrt{k_v E/F_y}$

$$C_v = \frac{1.51 E k_v}{(h/t_w)^2 F_y} \quad (\text{G2-5})$$

where

A_w = the overall depth times the web thickness, dt_w , in.² (mm²)

The web plate buckling coefficient, k_v , is determined as follows:

(i) For unstiffened webs with $h/t_w < 260$, $k_v = 5$ except for the stem of tee shapes where $k_v = 1.2$.

(ii) For stiffened webs,

$$\begin{aligned} k_v &= 5 + \frac{5}{(a/h)^2} \\ &= 5 \text{ when } a/h > 3.0 \text{ or } a/h > \left[\frac{260}{(h/t_w)} \right]^2 \end{aligned}$$

where

a = clear distance between transverse *stiffeners*, in. (mm)

h = for rolled shapes, the clear distance between flanges less the fillet or corner radii, in. (mm)

axes, respectively, considering the member loaded in bending only as prescribed in Clause 2.6.5.

In addition, the compressive bending stress alone shall be checked against the lateral torsional buckling stress.

2.6.8 Equivalent Stress f_e

Whenever the material is subjected to axial and shear stresses, the equivalent stress (f_e) must not exceed the permitted stresses given in this code plus 10%, and the equivalent stress shall be calculated as follows:

$$f_e = \sqrt{f^2 + 3q^2} \leq 1.1 F_{all} \dots\dots\dots 2.39$$

2.7 EFFECTIVE AREAS

2.7.1 Effective Net Area

The effective net sectional-area of a tension member shall be used. This area is the sum of the products of the thickness and net width of each element as measured normal to the axis of the member. For a chain of holes extending across a part in any diagonal or zigzag line, the net width of the parts shall be obtained by deducting from the gross width the sum of the diameters of all holes in the chain and adding, for each gauge space in the chain, the quantity ($s^2/4g$).

Where:

s = The staggered pitch, i.e., the distance, measured parallel to the direction of stress in the member, centre to centre of holes in consecutive lines.

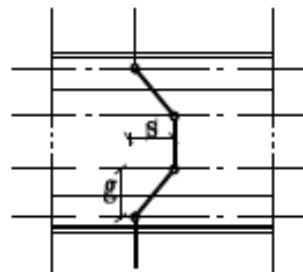

t = The thickness of the material.

g = The gauge, i.e., the distance, measured at right angles to the direction of stress in the member, centre to centre of holes in consecutive lines.

6.5.2.6 Design Strength in Connections Subjected to Combined Shear and Bending Moment

In moment connections of the type shown in Fig. 6.6, the loss of clamping forces in region “A” is always coupled with a corresponding increase in contact pressure in region “B”. The clamping force remains unchanged and there is no decrease of the frictional resistance as given by the following :-

$$P_s = \mu T / \gamma \quad \dots\dots\dots 6.14$$

The induced maximum tensile force $T_{(ext,b,M)}$ due to the applied moment (M) in addition to the prying force P that may occur, must not exceed the pretension force as follows:-

$$T_{(ext,b,M)} + P \leq 0.8T \quad \dots\dots\dots 6.15$$

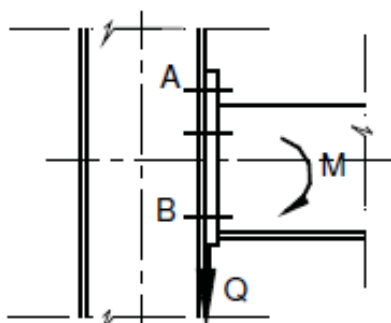

Figure (6.6) Connections Subjected to Combined Shear and Bending Moment

6.5.2.7 Design Strength in Connections Subjected to Combined Shear, Tension, and Bending Moment

When the connection is subjected to shearing force (Q), a tension force (T_{ext}) and a bending moment (M), the design strength per bolt is to be according to the following formulae:-

6.9.2 Determination of The Prying Force P

In order to determine the prying force P, the connection is to be transformed to an equivalent Tee stub connection as shown in Fig. 6.11. The prying force P can be determined using the following relation :-

$$P = \left[\frac{\frac{1}{2} - \frac{wt_p^4}{30ab^2 A_s}}{\left(\frac{3a}{4}\right)\left(\frac{a}{4b} + 1\right) + \frac{wt_p^4}{30ab^2 A_s}} \right] \cdot T_{\text{ext,b,M}} \text{ OR } T_{\text{ext,b}} \dots \quad 6.24$$

Where :

- a,b = Bolt outer overhanging and inner bolt dimension with respect to the stem Tee stub respectively in cm.
- w = Flange Tee stub breadth with respect to one column of bolts.
- A_s = Bolt stress area.
- $T_{\text{ext,b}}$, $T_{\text{ext,b,M}}$ = Applied external tension force on one bolt column due to either an applied external tension force T_{ext} (Fig. 6.10a) or due to the replacement of the applied moment (M) by two equal external and opposite forces $T_b = C_b = \frac{M}{d_b}$ (Fig. 6.10b) or due to an exact analysis of an end plate moment connection (Fig. 6.10c)

Where $T_{\text{ext,b}} = \frac{T_{\text{ext}}}{4}$ (Fig. 6.10a)

$$T_{\text{ext,b,M}} = \frac{T_b}{4} \quad (\text{Fig. 6.10b})$$

Where

\bar{w} = Half breadth of end plate = half breadth of Tee-stub flange.

w = \bar{w} for case of two columns of bolts .

$$T_{ext,b,M} + P \leq 0.8 T \quad \dots\dots\dots 6.28$$

6.9.4 Safety Requirements for Beam to Column Connections

i. Column web at the vicinity of the compression beam flange “ crippling of the column web ” :

Crippling of the column web is prevented if :

$$t_{wc} \geq \frac{b_b t_b}{t_b + 2t_p + 5k} \quad \dots\dots\dots 6.29$$

If Equation 6.29 is not satisfied, use a pair of horizontal stiffeners fulfilling the following condition :

$$2b_{st} t_{st} \geq b_b t_b - (t_b + 2t_p + 5k)t_{wc} \quad \dots\dots\dots 6.30$$

In order to prevent the local buckling of these stiffeners:

$$b_{st} / t_{st} \leq 25 / \sqrt{F_y} \quad \dots\dots\dots 6.31$$

ii. Column flange at the location of the tension beam flange “ bending of the column flange ”:

Bending of the column flange is prevented if:

$$\dots\dots\dots 6.32$$

If Equation 6.32 is not satisfied, use a pair of horizontal stiffeners fulfilling the condition of Equation 6.30:

Table (6.3) Properties and Strength of High Strength Bolts (Grade 10.9*)

Bolt Diameter (d) mm	Bolt Area (A) cm ²	Stress Area (A _s) cm ²	Pretension Force (T) tons	Required Torque (M _b) kg.m	Permissible Friction Load of One Bolt Per One Friction Surface (P _s) tons									
					Ordinary Steel Work				Bridges and Cranes					
					St. 37&42-44 (μ=0.4)		St. 50-55 (μ=0.5)		St. 37&42-44 (μ=0.4)		St. 50-55 (μ=0.5)			
					Cases of Loading				Cases of Loading					
					I	II	I	II	I	II	I	II	I	II
M12	1.13	0.84	5.29	12	1.69	2.01	2.11	2.52	1.32	1.56	1.65	1.95	1.95	1.95
M16	2.01	1.57	9.89	31	3.16	3.37	3.95	4.71	2.47	2.92	3.09	3.66	3.66	3.66
M20	3.14	2.45	15.43	62	4.93	5.90	6.17	7.36	3.85	4.56	4.82	5.71	5.71	5.71
M22	3.80	3.03	19.08	84	6.10	7.27	7.63	9.10	4.77	5.65	5.96	7.06	7.06	7.06
M24	4.52	3.53	22.23	107	7.11	8.45	8.89	10.60	5.55	6.58	6.94	8.22	8.22	8.22
M27	5.73	4.59	28.91	157	9.25	11.03	11.56	13.78	7.22	8.55	9.03	10.70	10.70	10.70
M30	7.06	5.61	35.34	213	11.30	13.48	14.13	16.86	8.83	10.46	11.04	13.07	13.07	13.07
M36	10.18	8.17	51.47	372	16.47	19.64	20.58	24.55	12.86	15.24	16.08	19.05	19.05	19.05

$$T = (0.7) F_{yb} \cdot A_s \quad M_b = 0.2 \text{ d.T.} \quad P_s = \mu T / \gamma$$

* For HSB grade 8.8, the above values shall be reduced by 30%

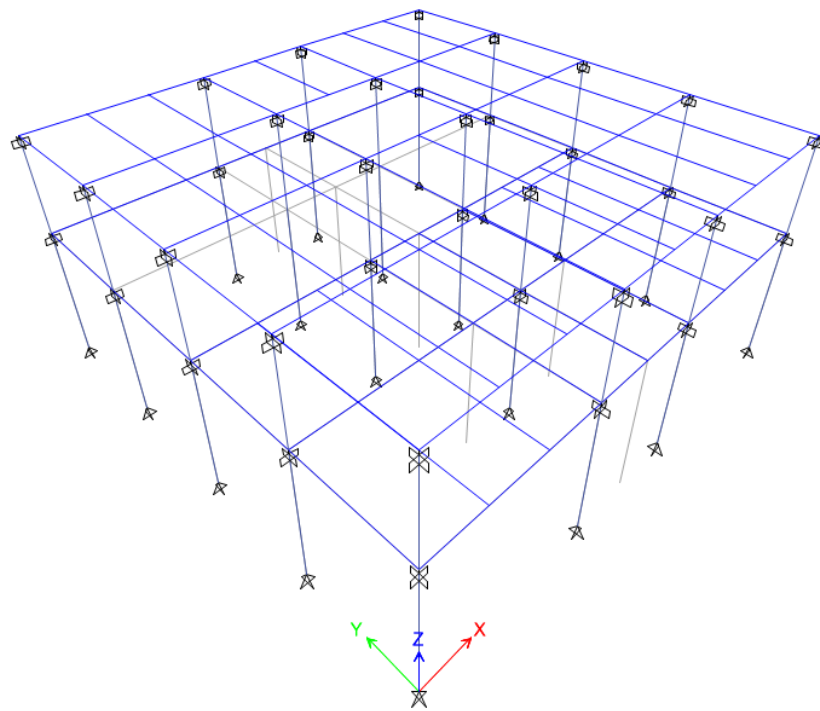

1 Structure Data

This chapter provides model geometry information, including items such as story levels, point coordinates, and element connectivity.

1.1 Story Data

Story Data

Name	Height m	Elevation m	Master Story	Similar To	Splice Story
Roof	5	12	No	None	No
Mezzanine	7	7	No	None	No
Base	0	0	No	None	No

1.2 Grid Data

Grid Systems

Name	Type	Story Range	X Origin m	Y Origin m	Rotatio n deg	Bubble Size m	Color
G1	Cartesia n	Default	0	0	0	1.25	ffa0a0a0

Grid Lines

Grid System	Grid Directio n	Grid ID	Visible	Bubble Locatio n	Ordinat e m
G1	X	A	Yes	End	0
G1	X	B	Yes	End	9
G1	X	C	Yes	End	12
G1	X	D	Yes	End	15
G1	X	E	Yes	End	24
G1	Y	1	Yes	Start	0
G1	Y	2	Yes	Start	6
G1	Y	3	Yes	Start	12
G1	Y	4	Yes	Start	18
G1	Y	5	Yes	Start	24

1.3 Point Coordinates

Joint Coordinates Data

Label	X m	Y m	ΔZ Below m
1	24	18	0
2	24	12	0
5	0	6	0
6	0	12	0
7	0	18	0
8	0	24	0
9	0	0	0
10	24	6	0
11	24	24	0
12	24	0	0
13	12	6	0
14	12	12	0
16	12	24	0
17	12	0	0
23	15	12	0
24	18	12	0
25	21	12	0
26	3	0	0
27	6	0	0
28	9	0	0
29	15	0	0
30	18	0	0
31	21	0	0
32	3	6	0
33	6	6	0
34	9	6	0
35	15	6	0
36	18	6	0
37	21	6	0
38	3	12	0
39	6	12	0
40	9	12	0
4	15	18	0
18	9	18	0
15	12	18	0
19	9	24	0
20	6	18	0
21	6	24	0

Label	X m	Y m	ΔZ Below m
22	3	18	0
41	3	24	0
42	21	18	0
43	21	24	0
44	18	18	0
45	18	24	0
46	15	24	0
47	0	6	1
48	0	12	1
49	0	18	1
50	0	24	1
51	12	0	1
52	12	6	1
53	12	12	1
54	12	24	1
56	24	6	1
57	24	12	1
58	24	18	1
59	24	24	1
61	9	18	1
62	15	12	1
63	9	12	1

1.4 Line Connectivity

Column Connectivity Data

Column	I-End Point	J-End Point	I-End Story
C16	9	9	Below
C23	5	5	Below
C24	6	6	Below
C25	7	7	Below
C26	8	8	Below
C28	13	13	Below
C32	12	12	Below
C33	10	10	Below
C34	2	2	Below
C35	1	1	Below
C36	11	11	Below
C2	4	4	Below
C3	18	18	Below

Column	I-End Point	J-End Point	I-End Story
C4	23	23	Below
C5	40	40	Below
C1	29	29	Below
C6	28	28	Below
C7	19	19	Below
C8	46	46	Below

Beam Connectivity Data

Beam	I-End Point	J-End Point	Curve Type
B1	31	37	None
B2	30	36	None
B3	29	35	None
B4	12	10	None
B5	17	13	None
B6	28	34	None
B7	27	33	None
B8	26	32	None
B9	9	5	None
B10	37	25	None
B39	36	24	None
B40	35	23	None
B41	10	2	None
B42	13	14	None
B43	34	40	None
B44	33	39	None
B45	32	38	None
B46	5	6	None
B52	5	13	None
B60	13	10	None
B15	6	7	None
B17	2	1	None
B18	7	8	None
B20	1	11	None
B11	23	2	None
B12	4	1	None
B16	18	4	None
B19	7	18	None
B21	6	40	None
B22	40	23	None
B23	23	4	None
B24	40	18	None

Beam	I-End Point	J-End Point	Curve Type
B25	15	16	None
B26	18	19	None
B27	20	21	None
B28	22	41	None
B29	42	43	None
B30	44	45	None
B31	4	46	None
B32	25	42	None
B33	24	44	None
B34	39	20	None
B35	38	22	None
B49	29	12	None
B51	9	28	None
B53	28	29	None
B57	8	19	None
B59	46	11	None
B61	19	46	None

1.5 Mass

Mass Source

Name	Include Elements	Include Added Mass	Include Loads	Include Lateral	Include Vertical	Lump at Stories	IsDefault
MsSrc1	Yes	Yes	No	Yes	No	Yes	Yes

Mass Summary by Story

Story	UX tonf-s ² /m	UY tonf-s ² /m	UZ tonf-s ² /m
Roof	3.52277	3.52277	0
Mezzanine	4.17327	4.17327	0
Base	1.05386	1.05386	0

1.6 Groups

Group Definitions

Name	Color
All	Yellow

2 Properties

This chapter provides property information for materials, frame sections, shell sections, and links.

2.1 Materials

Material Properties - Summary

Name	Type	E tonf/m ²	ν	Unit Weight tonf/m ³	Design Strengths
A615Gr60	Rebar	20389019.16	0.3	7.849	Fy=42184.18 tonf/m ² , Fu=63276.27 tonf/m ²
A992Fy50	Steel	20389019.16	0.3	7.849	Fy=35153.48 tonf/m ² , Fu=45699.53 tonf/m ²

2.2 Frame Sections

Frame Sections - Summary

Name	Material	Shape
HE400A	A992Fy50	Steel I/Wide Flange
HE400B	A992Fy50	Steel I/Wide Flange
HE450A	A992Fy50	Steel I/Wide Flange
HE500B	A992Fy50	Steel I/Wide Flange
IPE360	A992Fy50	Steel I/Wide Flange
IPE450	A992Fy50	Steel I/Wide Flange

2.3 Reinforcement Sizes

Reinforcing Bar Sizes

Name	Diameter m	Area m ²
10	0.01	7.9E-05
20	0.02	0.000314

3 Assignments

This chapter provides a listing of the assignments applied to the model.

3.1 Joint Assignments

Joint Assignments - Summary

Story	Label	Unique Name	Diaphragm	Restraints
Roof	1	109	From Area	UX; UY; UZ; RX; RY; RZ
Roof	2	105	From Area	UX; UY; UZ; RX; RY; RZ
Roof	5	61	From Area	UX; UY; UZ; RX; RY; RZ
Roof	6	65	From Area	UX; UY; UZ; RX; RY; RZ
Roof	7	69	From Area	UX; UY; UZ; RX; RY; RZ
Roof	8	73	From Area	UX; UY; UZ; RX; RY; RZ
Roof	9	57	From Area	UX; UY; UZ; RX; RY; RZ
Roof	10	101	From Area	UX; UY; UZ; RX; RY; RZ
Roof	11	113	From Area	UX; UY; UZ; RX; RY; RZ
Roof	12	97	From Area	UX; UY; UZ; RX; RY; RZ
Roof	13	81	From Area	UX; UY; UZ; RX; RY; RZ
Roof	14	85	From Area	
Roof	16	93	From Area	
Roof	17	77	From Area	
Roof	23	12	From Area	UX; UY; UZ; RX; RY; RZ
Roof	24	30	From Area	
Roof	25	29	From Area	
Roof	26	27	From Area	
Roof	27	25	From Area	
Roof	28	23	From Area	UX; UY; UZ; RX; RY; RZ
Roof	29	21	From Area	UX; UY; UZ; RX; RY; RZ
Roof	30	19	From Area	
Roof	31	17	From Area	
Roof	32	28	From Area	
Roof	33	26	From Area	
Roof	34	22	From Area	
Roof	35	16	From Area	
Roof	36	20	From Area	
Roof	37	18	From Area	
Roof	38	32	From Area	
Roof	39	31	From Area	
Roof	40	15	From Area	UX; UY; UZ; RX; RY; RZ
Roof	4	5	From Area	UX; UY; UZ; RX; RY; RZ
Roof	18	9	From Area	UX; UY; UZ; RX; RY; RZ
Roof	15	24	From Area	
Roof	19	33	From Area	UX; UY; UZ; RX; RY; RZ

Story	Label	Unique Name	Diaphragm	Restraints
Roof	20	34	From Area	
Roof	21	35	From Area	
Roof	22	36	From Area	
Roof	41	37	From Area	
Roof	42	38	From Area	
Roof	43	39	From Area	
Roof	44	40	From Area	
Roof	45	41	From Area	
Roof	46	42	From Area	UX; UY; UZ; RX; RY; RZ
Mezzanine	1	108	From Area	UX; UY; UZ; RX; RY; RZ
Mezzanine	2	104	From Area	UX; UY; UZ; RX; RY; RZ
Mezzanine	5	60	From Area	UX; UY; UZ; RX; RY; RZ
Mezzanine	6	64	From Area	UX; UY; UZ; RX; RY; RZ
Mezzanine	7	68	From Area	UX; UY; UZ; RX; RY; RZ
Mezzanine	8	72	From Area	UX; UY; UZ; RX; RY; RZ
Mezzanine	9	56	From Area	UX; UY; UZ; RX; RY; RZ
Mezzanine	10	100	From Area	UX; UY; UZ; RX; RY; RZ
Mezzanine	11	112	From Area	UX; UY; UZ; RX; RY; RZ
Mezzanine	12	96	From Area	UX; UY; UZ; RX; RY; RZ
Mezzanine	13	80	From Area	UX; UY; UZ; RX; RY; RZ
Mezzanine	14	84	From Area	
Mezzanine	16	92	From Area	
Mezzanine	17	76	From Area	
Mezzanine	23	134	From Area	UX; UY; UZ; RX; RY; RZ
Mezzanine	24	135	From Area	
Mezzanine	25	136	From Area	
Mezzanine	26	119	From Area	
Mezzanine	27	120	From Area	
Mezzanine	28	121	From Area	UX; UY; UZ; RX; RY; RZ
Mezzanine	29	122	From Area	UX; UY; UZ; RX; RY; RZ
Mezzanine	30	123	From Area	
Mezzanine	31	124	From Area	
Mezzanine	32	125	From Area	
Mezzanine	33	126	From Area	
Mezzanine	34	53	From Area	
Mezzanine	35	52	From Area	
Mezzanine	36	129	From Area	
Mezzanine	37	130	From Area	
Mezzanine	38	131	From Area	
Mezzanine	39	132	From Area	
Mezzanine	40	133	From Area	UX; UY; UZ; RX; RY; RZ
Mezzanine	4	4	From Area	

Story	Label	Unique Name	Diaphragm	Restraints
Mezzanine	18	8	From Area	
Mezzanine	19	48	From Area	UX; UY; UZ; RX; RY; RZ
Mezzanine	46	51	From Area	UX; UY; UZ; RX; RY; RZ
Mezzanine	47	59	From Area	
Mezzanine	48	63	From Area	
Mezzanine	49	67	From Area	
Mezzanine	50	71	From Area	
Mezzanine	51	75	From Area	
Mezzanine	52	79	From Area	
Mezzanine	53	83	From Area	
Mezzanine	54	91	From Area	
Mezzanine	56	99	From Area	
Mezzanine	57	103	From Area	
Mezzanine	58	107	From Area	
Mezzanine	59	111	From Area	
Mezzanine	61	7	From Area	
Mezzanine	62	11	From Area	
Mezzanine	63	14	From Area	
Base	1	106	From Area	UX; UY; UZ
Base	2	102	From Area	UX; UY; UZ
Base	5	58	From Area	UX; UY; UZ
Base	6	62	From Area	UX; UY; UZ
Base	7	66	From Area	UX; UY; UZ
Base	8	70	From Area	UX; UY; UZ
Base	9	54	From Area	UX; UY; UZ
Base	10	98	From Area	UX; UY; UZ
Base	11	110	From Area	UX; UY; UZ
Base	12	94	From Area	UX; UY; UZ
Base	13	78	From Area	UX; UY; UZ
Base	23	10	From Area	UX; UY; UZ
Base	28	44	From Area	UX; UY; UZ
Base	29	1	From Area	UX; UY; UZ
Base	40	13	From Area	UX; UY; UZ
Base	4	2	From Area	UX; UY; UZ
Base	18	6	From Area	UX; UY; UZ
Base	19	46	From Area	UX; UY; UZ
Base	46	49	From Area	UX; UY; UZ

3.2 Frame Assignments

Table 3.2 - Frame Assignments - Summary

Story	Label	Unique Name	Design Type	Length m	Analysis Section	Design Section	Max Station Spacing m	Min Number Stations	Releases
Roof	C16	36	Column	5	HE400B	HE400B		3	No
Roof	C23	39	Column	5	HE400B	HE400B		3	No
Roof	C24	42	Column	5	HE400B	HE400B		3	No
Roof	C25	45	Column	5	HE400B	HE400B		3	No
Roof	C26	48	Column	5	HE400B	HE400B		3	No
Roof	C28	54	Column	5	HE400B	HE400B		3	No
Roof	C32	66	Column	5	HE400B	HE400B		3	No
Roof	C33	69	Column	5	HE400B	HE400B		3	No
Roof	C34	72	Column	5	HE400B	HE400B		3	No
Roof	C35	75	Column	5	HE400B	HE400B		3	No
Roof	C36	78	Column	5	HE400B	HE400B		3	No
Roof	C2	33	Column	5	HE400B	HE400B		3	No
Roof	C3	59	Column	5	HE400B	HE400B		3	No
Roof	C4	80	Column	5	HE400B	HE400B		3	No
Roof	C5	83	Column	5	HE400B	HE400B		3	No
Roof	C1	132	Column	5	HE400B	HE400B		3	No
Roof	C6	135	Column	5	HE400B	HE400B		3	No
Roof	C7	50	Column	5	HE400B	HE400B		3	No
Roof	C8	94	Column	5	HE400B	HE400B		3	No
Mezzanine	C16	34	Column	7	HE400B	HE400B		3	No
Mezzanine	C23	37	Column	7	HE400B	HE400B		3	No
Mezzanine	C24	40	Column	7	HE400B	HE400B		3	No
Mezzanine	C25	43	Column	7	HE400B	HE400B		3	No
Mezzanine	C26	46	Column	7	HE400B	HE400B		3	No
Mezzanine	C28	52	Column	7	HE400B	HE400B		3	No
Mezzanine	C32	64	Column	7	HE400B	HE400B		3	No
Mezzanine	C33	67	Column	7	HE400B	HE400B		3	No
Mezzanine	C34	70	Column	7	HE400B	HE400B		3	No
Mezzanine	C35	73	Column	7	HE400B	HE400B		3	No
Mezzanine	C36	76	Column	7	HE400B	HE400B		3	No
Mezzanine	C2	31	Column	7	HE400B	HE400B		3	No
Mezzanine	C3	57	Column	7	HE400B	HE400B		3	No
Mezzanine	C4	60	Column	7	HE400B	HE400B		3	No
Mezzanine	C5	81	Column	7	HE400B	HE400B		3	No
Mezzanine	C1	2	Column	7	HE400B	HE400B		3	No
Mezzanine	C6	133	Column	7	HE400B	HE400B		3	No

Story	Label	Unique Name	Design Type	Length m	Analysis Section	Design Section	Max Station Spacing m	Min Number Stations	Releases
Mezzanine	C7	22	Column	7	HE400B	HE400B		3	No
Mezzanine	C8	51	Column	7	HE400B	HE400B		3	No
Roof	B1	109	Beam	6	IPE360	IPE360	0.5		No
Roof	B2	110	Beam	6	IPE360	IPE360	0.5		No
Roof	B3	61	Beam	6	IPE360	IPE360	0.5		No
Roof	B4	25	Beam	6	IPE360	IPE360	0.5		No
Roof	B5	95	Beam	6	IPE360	IPE360	0.5		No
Roof	B6	63	Beam	6	IPE360	IPE360	0.5		No
Roof	B7	113	Beam	6	IPE360	IPE360	0.5		No
Roof	B8	114	Beam	6	IPE360	IPE360	0.5		No
Roof	B9	92	Beam	6	IPE360	IPE360	0.5		No
Roof	B10	115	Beam	6	IPE360	IPE360	0.5		No
Roof	B39	116	Beam	6	IPE360	IPE360	0.5		No
Roof	B40	62	Beam	6	IPE360	IPE360	0.5		No
Roof	B41	28	Beam	6	IPE360	IPE360	0.5		No
Roof	B42	104	Beam	6	IPE360	IPE360	0.5		No
Roof	B43	85	Beam	6	IPE360	IPE360	0.5		No
Roof	B44	119	Beam	6	IPE360	IPE360	0.5		No
Roof	B45	120	Beam	6	IPE360	IPE360	0.5		No
Roof	B46	91	Beam	6	IPE360	IPE360	0.5		No
Roof	B52	107	Beam	12	HE500B	HE500B	0.5		No
Roof	B60	108	Beam	12	HE500B	HE500B	0.5		No
Roof	B15	88	Beam	6	IPE360	IPE360	0.5		No
Roof	B17	30	Beam	6	IPE360	IPE360	0.5		No
Roof	B18	87	Beam	6	IPE360	IPE360	0.5		No
Roof	B20	84	Beam	6	IPE360	IPE360	0.5		No
Roof	B11	96	Beam	9	HE400 A	HE400 A	0.5		No
Roof	B12	97	Beam	9	HE400 A	HE400 A	0.5		No
Roof	B16	98	Beam	6	IPE450	IPE450	0.5		No
Roof	B19	99	Beam	9	HE400 A	HE400 A	0.5		No
Roof	B21	100	Beam	9	HE400 A	HE400 A	0.5		No
Roof	B22	101	Beam	6	IPE450	IPE450	0.5		No
Roof	B23	102	Beam	6	IPE450	IPE450	0.5		No
Roof	B24	103	Beam	6	IPE450	IPE450	0.5		No
Roof	B25	86	Beam	6	IPE360	IPE360	0.5		No
Roof	B26	121	Beam	6	IPE360	IPE360	0.5		No

Story	Label	Unique Name	Design Type	Length m	Analysis Section	Design Section	Max Station Spacing m	Min Number Stations	Releases
Roof	B27	122	Beam	6	IPE360	IPE360	0.5		No
Roof	B28	123	Beam	6	IPE360	IPE360	0.5		No
Roof	B29	124	Beam	6	IPE360	IPE360	0.5		No
Roof	B30	125	Beam	6	IPE360	IPE360	0.5		No
Roof	B31	126	Beam	6	IPE360	IPE360	0.5		No
Roof	B32	127	Beam	6	IPE360	IPE360	0.5		No
Roof	B33	128	Beam	6	IPE360	IPE360	0.5		No
Roof	B34	129	Beam	6	IPE360	IPE360	0.5		No
Roof	B35	130	Beam	6	IPE360	IPE360	0.5		No
Roof	B49	143	Beam	9	HE400 A	HE400 A	0.5		No
Roof	B51	138	Beam	9	HE400 A	HE400 A	0.5		No
Roof	B53	141	Beam	6	HE400 A	HE400 A	0.5		No
Roof	B57	153	Beam	9	HE400 A	HE400 A	0.5		No
Roof	B59	150	Beam	9	HE400 A	HE400 A	0.5		No
Roof	B61	149	Beam	6	HE400 A	HE400 A	0.5		No
Mezzanine	B1	1	Beam	6	IPE450	IPE450	0.5		Yes
Mezzanine	B2	3	Beam	6	IPE450	IPE450	0.5		Yes
Mezzanine	B3	89	Beam	6	IPE450	IPE450	0.5		No
Mezzanine	B4	5	Beam	6	IPE450	IPE450	0.5		Yes
Mezzanine	B5	6	Beam	6	IPE450	IPE450	0.5		Yes
Mezzanine	B6	105	Beam	6	IPE450	IPE450	0.5		No
Mezzanine	B7	8	Beam	6	IPE450	IPE450	0.5		Yes
Mezzanine	B8	9	Beam	6	IPE450	IPE450	0.5		Yes
Mezzanine	B9	10	Beam	6	IPE450	IPE450	0.5		Yes
Mezzanine	B10	11	Beam	6	IPE450	IPE450	0.5		Yes
Mezzanine	B39	12	Beam	6	IPE450	IPE450	0.5		Yes
Mezzanine	B40	90	Beam	6	IPE450	IPE450	0.5		No
Mezzanine	B41	14	Beam	6	IPE450	IPE450	0.5		Yes
Mezzanine	B42	15	Beam	6	IPE450	IPE450	0.5		Yes
Mezzanine	B43	111	Beam	6	IPE450	IPE450	0.5		No
Mezzanine	B44	17	Beam	6	IPE450	IPE450	0.5		Yes
Mezzanine	B45	18	Beam	6	IPE450	IPE450	0.5		Yes
Mezzanine	B46	19	Beam	6	IPE450	IPE450	0.5		Yes
Mezzanine	B52	20	Beam	12	HE500B	HE500B	0.5		No

Story	Label	Unique Name	Design Type	Length m	Analysis Section	Design Section	Max Station Spacing m	Min Number Stations	Releases
Mezzanine	B60	21	Beam	12	HE500B	HE500B	0.5		No
Mezzanine	B15	24	Beam	6	IPE450	IPE450	0.5		Yes
Mezzanine	B17	26	Beam	6	IPE450	IPE450	0.5		Yes
Mezzanine	B18	27	Beam	6	IPE450	IPE450	0.5		Yes
Mezzanine	B20	29	Beam	6	IPE450	IPE450	0.5		Yes
Mezzanine	B11	106	Beam	9	HE450 A	HE450 A	0.5		No
Mezzanine	B21	55	Beam	9	HE450 A	HE450 A	0.5		No
Mezzanine	B22	56	Beam	6	HE450 A	HE450 A	0.5		No
Mezzanine	B49	137	Beam	9	HE400 A	HE400 A	0.5		No
Mezzanine	B51	23	Beam	9	HE400 A	HE400 A	0.5		No
Mezzanine	B53	136	Beam	6	HE400 A	HE400 A	0.5		No
Mezzanine	B57	139	Beam	9	HE400 A	HE400 A	0.5		No
Mezzanine	B59	146	Beam	9	HE400 A	HE400 A	0.5		No
Mezzanine	B61	144	Beam	6	HE400 A	HE400 A	0.5		No

4 Loads

This chapter provides loading information as applied to the model.

4.1 Load Patterns

Load Patterns

Name	Type	Self-Weight Multiplier
Dead	Dead	0
Live	Live	0

4.2 Applied Loads

4.2.1 Line Loads

Frame Loads - Point

Story	Label	Unique Name	Design Type	Load Pattern	Load Type	Direction	Relative Distance	Absolute Distance	Force tonf
Roof	B16	98	Beam	Dead	Force	Gravity	0.5	3	17.1
Roof	B22	101	Beam	Dead	Force	Gravity	0.5	3	17.1
Roof	B23	102	Beam	Dead	Force	Gravity	0.5	3	17.1
Roof	B24	103	Beam	Dead	Force	Gravity	0.5	3	17.1

Frame Loads - Distributed

Story	Label	Unique Name	Design Type	Load Pattern	Load Type	Direction	Relative Distance Start	Relative Distance End	Absolute Distance Start	Absolute Distance End	Force at Start tonf/m	Force at End tonf/m
Roof	B1	109	Beam	Dead	Force	Gravity	0	1	0	6	2.1	2.1
Roof	B2	110	Beam	Dead	Force	Gravity	0	1	0	6	2.1	2.1
Roof	B4	25	Beam	Dead	Force	Gravity	0	1	0	6	1.05	1.05
Roof	B5	95	Beam	Dead	Force	Gravity	0	1	0	6	2.1	2.1
Roof	B7	113	Beam	Dead	Force	Gravity	0	1	0	6	2.1	2.1

Story	Label	Unique Name	Design Type	Load Pattern	Load Type	Direction	Relative Distance Start	Relative Distance End	Absolute Distance Start m	Absolute Distance End m	Force at Start tonf/m	Force at End tonf/m
Roof	B8	114	Beam	Dead	Force	Gravity	0	1	0	6	2.1	2.1
Roof	B9	92	Beam	Dead	Force	Gravity	0	1	0	6	1.05	1.05
Roof	B10	115	Beam	Dead	Force	Gravity	0	1	0	6	2.1	2.1
Roof	B39	116	Beam	Dead	Force	Gravity	0	1	0	6	2.1	2.1
Roof	B41	28	Beam	Dead	Force	Gravity	0	1	0	6	1.05	1.05
Roof	B42	104	Beam	Dead	Force	Gravity	0	1	0	6	2.1	2.1
Roof	B44	119	Beam	Dead	Force	Gravity	0	1	0	6	2.1	2.1
Roof	B45	120	Beam	Dead	Force	Gravity	0	1	0	6	2.1	2.1
Roof	B46	91	Beam	Dead	Force	Gravity	0	1	0	6	1.05	1.05
Roof	B52	107	Beam	Dead	Force	Gravity	0	1	0	12	0.19	0.19
Roof	B60	108	Beam	Dead	Force	Gravity	0	1	0	12	0.19	0.19
Roof	B15	88	Beam	Dead	Force	Gravity	0	1	0	6	1.05	1.05
Roof	B17	30	Beam	Dead	Force	Gravity	0	1	0	6	1.05	1.05
Roof	B18	87	Beam	Dead	Force	Gravity	0	1	0	6	1.05	1.05
Roof	B20	84	Beam	Dead	Force	Gravity	0	1	0	6	1.05	1.05
Roof	B11	96	Beam	Dead	Force	Gravity	0	1	0	9	0.13	0.13
Roof	B12	97	Beam	Dead	Force	Gravity	0	1	0	9	0.13	0.13
Roof	B16	98	Beam	Dead	Force	Gravity	0	1	0	6	1.02	1.02
Roof	B19	99	Beam	Dead	Force	Gravity	0	1	0	9	0.13	0.13

Story	Label	Unique Name	Design Type	Load Pattern	Load Type	Direction	Relative Distance Start	Relative Distance End	Absolute Distance Start m	Absolute Distance End m	Force at Start tonf/m	Force at End tonf/m
Roof	B21	100	Beam	Dead	Force	Gravity	0	1	0	9	0.13	0.13
Roof	B22	101	Beam	Dead	Force	Gravity	0	1	0	6	1.02	1.02
Roof	B23	102	Beam	Dead	Force	Gravity	0	1	0	6	1.02	1.02
Roof	B24	103	Beam	Dead	Force	Gravity	0	1	0	6	1.02	1.02
Roof	B26	121	Beam	Dead	Force	Gravity	0	1	0	6	2.1	2.1
Roof	B27	122	Beam	Dead	Force	Gravity	0	1	0	6	2.1	2.1
Roof	B28	123	Beam	Dead	Force	Gravity	0	1	0	6	2.1	2.1
Roof	B29	124	Beam	Dead	Force	Gravity	0	1	0	6	2.1	2.1
Roof	B30	125	Beam	Dead	Force	Gravity	0	1	0	6	2.1	2.1
Roof	B31	126	Beam	Dead	Force	Gravity	0	1	0	6	2.1	2.1
Roof	B32	127	Beam	Dead	Force	Gravity	0	1	0	6	2.1	2.1
Roof	B33	128	Beam	Dead	Force	Gravity	0	1	0	6	2.1	2.1
Roof	B34	129	Beam	Dead	Force	Gravity	0	1	0	6	2.1	2.1
Roof	B35	130	Beam	Dead	Force	Gravity	0	1	0	6	2.1	2.1
Roof	B49	143	Beam	Dead	Force	Gravity	0	0.3333	0	3	0.19	0.19
Roof	B49	143	Beam	Dead	Force	Gravity	0.3333	0.6666	3	6	0.19	0.19
Roof	B49	143	Beam	Dead	Force	Gravity	0.6666	1	6	9	0.19	0.19
Roof	B51	138	Beam	Dead	Force	Gravity	0	0.3333	0	3	0.19	0.19
Roof	B51	138	Beam	Dead	Force	Gravity	0.3333	0.6666	3	6	0.19	0.19

Story	Label	Unique Name	Design Type	Load Pattern	Load Type	Direction	Relative Distance Start	Relative Distance End	Absolute Distance Start m	Absolute Distance End m	Force at Start tonf/m	Force at End tonf/m
Roof	B51	138	Beam	Dead	Force	Gravity	0.666667	1	6	9	0.19	0.19
Roof	B53	141	Beam	Dead	Force	Gravity	0	0.5	0	3	0.19	0.19
Roof	B53	141	Beam	Dead	Force	Gravity	0.5	1	3	6	0.19	0.19
Roof	B57	153	Beam	Dead	Force	Gravity	0	0.333333	0	3	0.13	0.13
Roof	B57	153	Beam	Dead	Force	Gravity	0.333333	0.666667	3	6	0.13	0.13
Roof	B57	153	Beam	Dead	Force	Gravity	0.666667	1	6	9	0.13	0.13
Roof	B59	150	Beam	Dead	Force	Gravity	0	0.333333	0	3	0.13	0.13
Roof	B59	150	Beam	Dead	Force	Gravity	0.333333	0.666667	3	6	0.13	0.13
Roof	B59	150	Beam	Dead	Force	Gravity	0.666667	1	6	9	0.13	0.13
Roof	B61	149	Beam	Dead	Force	Gravity	0.5	1	3	6	0.13	0.13
Roof	B61	149	Beam	Dead	Force	Gravity	0	0.5	0	3	0.13	0.13
Mezzanine	B1	1	Beam	Dead	Force	Gravity	0	1	0	6	2.11	2.11
Mezzanine	B2	3	Beam	Dead	Force	Gravity	0	1	0	6	2.11	2.11
Mezzanine	B4	5	Beam	Dead	Force	Gravity	0	1	0	6	1.55	1.55
Mezzanine	B5	6	Beam	Dead	Force	Gravity	0	1	0	6	2.11	2.11
Mezzanine	B7	8	Beam	Dead	Force	Gravity	0	1	0	6	2.11	2.11
Mezzanine	B8	9	Beam	Dead	Force	Gravity	0	1	0	6	2.11	2.11
Mezzanine	B9	10	Beam	Dead	Force	Gravity	0	1	0	6	1.55	1.55
Mezzanine	B10	11	Beam	Dead	Force	Gravity	0	1	0	6	2.11	2.11

Story	Label	Unique Name	Design Type	Load Pattern	Load Type	Direction	Relative Distance Start	Relative Distance End	Absolute Distance Start m	Absolute Distance End m	Force at Start tonf/m	Force at End tonf/m
Mezzanine	B39	12	Beam	Dead	Force	Gravity	0	1	0	6	2.11	2.11
Mezzanine	B41	14	Beam	Dead	Force	Gravity	0	1	0	6	1.55	1.55
Mezzanine	B42	15	Beam	Dead	Force	Gravity	0	1	0	6	2.11	2.11
Mezzanine	B44	17	Beam	Dead	Force	Gravity	0	1	0	6	2.11	2.11
Mezzanine	B45	18	Beam	Dead	Force	Gravity	0	1	0	6	2.11	2.11
Mezzanine	B46	19	Beam	Dead	Force	Gravity	0	1	0	6	1.55	1.55
Mezzanine	B52	20	Beam	Dead	Force	Gravity	0	1	0	12	0.19	0.19
Mezzanine	B60	21	Beam	Dead	Force	Gravity	0	1	0	12	0.19	0.19
Mezzanine	B15	24	Beam	Dead	Force	Gravity	0	1	0	6	0.58	0.58
Mezzanine	B17	26	Beam	Dead	Force	Gravity	0	1	0	6	0.58	0.58
Mezzanine	B18	27	Beam	Dead	Force	Gravity	0	1	0	6	0.58	0.58
Mezzanine	B20	29	Beam	Dead	Force	Gravity	0	1	0	6	0.58	0.58
Mezzanine	B11	106	Beam	Dead	Force	Gravity	0	1	0	9	1.58	1.58
Mezzanine	B21	55	Beam	Dead	Force	Gravity	0	1	0	9	1.58	1.58
Mezzanine	B22	56	Beam	Dead	Force	Gravity	0	1	0	6	1.58	1.58
Mezzanine	B49	137	Beam	Dead	Force	Gravity	0	0.3333	0	3	1.69	1.69
Mezzanine	B49	137	Beam	Dead	Force	Gravity	0.3333	0.6666	3	6	1.69	1.69
Mezzanine	B49	137	Beam	Dead	Force	Gravity	0.6666	1	6	9	1.69	1.69
Mezzanine	B51	23	Beam	Dead	Force	Gravity	0	0.3333	0	3	1.69	1.69

Story	Label	Unique Name	Design Type	Load Pattern	Load Type	Direction	Relative Distance Start	Relative Distance End	Absolute Distance Start m	Absolute Distance End m	Force at Start tonf/m	Force at End tonf/m
Mezzanine	B51	23	Beam	Dead	Force	Gravity	0.3333	0.6666	3	6	1.69	1.69
Mezzanine	B51	23	Beam	Dead	Force	Gravity	0.6666	1	6	9	1.69	1.69
Mezzanine	B53	136	Beam	Dead	Force	Gravity	0.5	1	3	6	1.69	1.69
Mezzanine	B53	136	Beam	Dead	Force	Gravity	0	0.5	0	3	1.69	1.69
Mezzanine	B57	139	Beam	Dead	Force	Gravity	0	0.3333	0	3	0.58	0.58
Mezzanine	B57	139	Beam	Dead	Force	Gravity	0.3333	0.6666	3	6	0.58	0.58
Mezzanine	B57	139	Beam	Dead	Force	Gravity	0.6666	1	6	9	0.58	0.58
Mezzanine	B59	146	Beam	Dead	Force	Gravity	0	0.3333	0	3	0.58	0.58
Mezzanine	B59	146	Beam	Dead	Force	Gravity	0.3333	0.6666	3	6	0.58	0.58
Mezzanine	B59	146	Beam	Dead	Force	Gravity	0.6666	1	6	9	0.58	0.58
Mezzanine	B61	144	Beam	Dead	Force	Gravity	0	0.5	0	3	0.58	0.58
Mezzanine	B61	144	Beam	Dead	Force	Gravity	0.5	1	3	6	0.58	0.58
Roof	B1	109	Beam	Live	Force	Gravity	0	1	0	6	0.75	0.75
Roof	B2	110	Beam	Live	Force	Gravity	0	1	0	6	0.75	0.75
Roof	B4	25	Beam	Live	Force	Gravity	0	1	0	6	0.38	0.38
Roof	B5	95	Beam	Live	Force	Gravity	0	1	0	6	0.75	0.75
Roof	B7	113	Beam	Live	Force	Gravity	0	1	0	6	0.75	0.75
Roof	B8	114	Beam	Live	Force	Gravity	0	1	0	6	0.75	0.75
Roof	B9	92	Beam	Live	Force	Gravity	0	1	0	6	0.38	0.38

Story	Label	Unique Name	Design Type	Load Pattern	Load Type	Direction	Relative Distance Start	Relative Distance End	Absolute Distance Start m	Absolute Distance End m	Force at Start tonf/m	Force at End tonf/m
Roof	B10	115	Beam	Live	Force	Gravity	0	1	0	6	0.75	0.75
Roof	B39	116	Beam	Live	Force	Gravity	0	1	0	6	0.75	0.75
Roof	B41	28	Beam	Live	Force	Gravity	0	1	0	6	0.38	0.38
Roof	B42	104	Beam	Live	Force	Gravity	0	1	0	6	0.75	0.75
Roof	B44	119	Beam	Live	Force	Gravity	0	1	0	6	0.75	0.75
Roof	B45	120	Beam	Live	Force	Gravity	0	1	0	6	0.75	0.75
Roof	B46	91	Beam	Live	Force	Gravity	0	1	0	6	0.38	0.38
Roof	B15	88	Beam	Live	Force	Gravity	0	1	0	6	0.38	0.38
Roof	B17	30	Beam	Live	Force	Gravity	0	1	0	6	0.38	0.38
Roof	B18	87	Beam	Live	Force	Gravity	0	1	0	6	0.38	0.38
Roof	B20	84	Beam	Live	Force	Gravity	0	1	0	6	0.38	0.38
Roof	B16	98	Beam	Live	Force	Gravity	0	1	0	6	1.5	1.5
Roof	B22	101	Beam	Live	Force	Gravity	0	1	0	6	1.5	1.5
Roof	B23	102	Beam	Live	Force	Gravity	0	1	0	6	1.13	1.13
Roof	B24	103	Beam	Live	Force	Gravity	0	1	0	6	1.13	1.13
Roof	B26	121	Beam	Live	Force	Gravity	0	1	0	6	0.75	0.75
Roof	B27	122	Beam	Live	Force	Gravity	0	1	0	6	0.75	0.75
Roof	B28	123	Beam	Live	Force	Gravity	0	1	0	6	0.75	0.75
Roof	B29	124	Beam	Live	Force	Gravity	0	1	0	6	0.75	0.75

Story	Label	Unique Name	Design Type	Load Pattern	Load Type	Direction	Relative Distance Start	Relative Distance End	Absolute Distance Start m	Absolute Distance End m	Force at Start tonf/m	Force at End tonf/m
Roof	B30	125	Beam	Live	Force	Gravity	0	1	0	6	0.75	0.75
Roof	B31	126	Beam	Live	Force	Gravity	0	1	0	6	0.75	0.75
Roof	B32	127	Beam	Live	Force	Gravity	0	1	0	6	0.75	0.75
Roof	B33	128	Beam	Live	Force	Gravity	0	1	0	6	0.75	0.75
Roof	B34	129	Beam	Live	Force	Gravity	0	1	0	6	0.75	0.75
Roof	B35	130	Beam	Live	Force	Gravity	0	1	0	6	0.75	0.75
Mezzanine	B1	1	Beam	Live	Force	Gravity	0	1	0	6	1.5	1.5
Mezzanine	B2	3	Beam	Live	Force	Gravity	0	1	0	6	1.5	1.5
Mezzanine	B4	5	Beam	Live	Force	Gravity	0	1	0	6	0.75	0.75
Mezzanine	B5	6	Beam	Live	Force	Gravity	0	1	0	6	1.5	1.5
Mezzanine	B7	8	Beam	Live	Force	Gravity	0	1	0	6	1.5	1.5
Mezzanine	B8	9	Beam	Live	Force	Gravity	0	1	0	6	1.5	1.5
Mezzanine	B9	10	Beam	Live	Force	Gravity	0	1	0	6	0.75	0.75
Mezzanine	B10	11	Beam	Live	Force	Gravity	0	1	0	6	1.5	1.5
Mezzanine	B39	12	Beam	Live	Force	Gravity	0	1	0	6	1.5	1.5
Mezzanine	B41	14	Beam	Live	Force	Gravity	0	1	0	6	0.75	0.75
Mezzanine	B42	15	Beam	Live	Force	Gravity	0	1	0	6	1.5	1.5
Mezzanine	B44	17	Beam	Live	Force	Gravity	0	1	0	6	1.5	1.5
Mezzanine	B45	18	Beam	Live	Force	Gravity	0	1	0	6	1.5	1.5

Story	Label	Unique Name	Design Type	Load Pattern	Load Type	Direction	Relative Distance Start	Relative Distance End	Absolute Distance Start m	Absolute Distance End m	Force at Start tonf/m	Force at End tonf/m
Mezzanine	B46	19	Beam	Live	Force	Gravity	0	1	0	6	0.75	0.75

4.3 Load Cases

Load Cases - Summary

Name	Type
Dead	Linear Static
Live	Linear Static

4.4 Load Combinations

Load Combinations

Name	Load Case/Combo	Scale Factor	Type	Auto
D	Dead	1.4	Linear Add	No
D+L	Dead	1.2	Linear Add	No
D+L	Live	1.6		No
DStlS1	Dead	1.4	Linear Add	Yes
DStlS2	Dead	1.2	Linear Add	Yes
DStlS2	Live	1.6		No
DStlD1	Dead	1	Linear Add	Yes
DStlD2	Dead	1	Linear Add	Yes
DStlD2	Live	1		No
DCon1	Dead	1.4	Linear Add	Yes
DCon2	Dead	1.2	Linear Add	Yes
DCon2	Live	1.6		No

5 Analysis Results

This chapter provides analysis results.

5.1 Structure Results

Base Reactions

Load Case/Combo	FX tonf	FY tonf	FZ tonf	MX tonf-m	MY tonf-m	MZ tonf-m	X m	Y m	Z m
Dead	0	0	685.72	7305.7	- 8228.59	0	0	0	0
Live	0	0	247.5	2443.5	-2970	0	0	0	0
D	0	0	960	10227.9 7	11520.0 3	0	0	0	0
D+L	0	0	1218.86	12676.4 4	- 14626.3 1	0	0	0	0
DStlS1	0	0	960	10227.9 7	11520.0 3	0	0	0	0
DStlS2	0	0	1218.86	12676.4 4	- 14626.3 1	0	0	0	0
DStlD1	0	0	685.72	7305.7	- 8228.59	0	0	0	0
DStlD2	0	0	933.22	9749.2	- 11198.5 9	0	0	0	0
DCon1	0	0	960	10227.9 7	11520.0 3	0	0	0	0
DCon2	0	0	1218.86	12676.4 4	- 14626.3 1	0	0	0	0

5.2 Story Results

Story Drifts

Story	Load Case/Combo	Label	Item	Drift	X m	Y m	Z m
Roof	Dead	46	Max Drift X	0	15	24	12
Roof	Dead	46	Max Drift Y	0	15	24	12
Roof	Live	46	Max Drift X	0	15	24	12
Roof	Live	46	Max Drift Y	0	15	24	12
Roof	D	46	Max Drift X	0	15	24	12
Roof	D	46	Max Drift Y	0	15	24	12
Roof	D+L	46	Max Drift X	0	15	24	12
Roof	D+L	46	Max Drift Y	0	15	24	12
Roof	DStlS1	46	Max Drift X	0	15	24	12
Roof	DStlS1	46	Max Drift Y	0	15	24	12
Roof	DStlS2	46	Max Drift X	0	15	24	12
Roof	DStlS2	46	Max Drift Y	0	15	24	12
Roof	DStlD1	46	Max Drift X	0	15	24	12
Roof	DStlD1	46	Max Drift Y	0	15	24	12
Roof	DStlD2	46	Max Drift X	0	15	24	12
Roof	DStlD2	46	Max Drift Y	0	15	24	12
Roof	DCon1	46	Max Drift X	0	15	24	12
Roof	DCon1	46	Max Drift Y	0	15	24	12
Roof	DCon2	46	Max Drift X	0	15	24	12
Roof	DCon2	46	Max Drift Y	0	15	24	12
Mezzanine	Dead	46	Max Drift X	0	15	24	7
Mezzanine	Dead	46	Max Drift Y	0	15	24	7
Mezzanine	Live	46	Max Drift X	0	15	24	7
Mezzanine	Live	46	Max Drift Y	0	15	24	7
Mezzanine	D	46	Max Drift X	0	15	24	7
Mezzanine	D	46	Max Drift Y	0	15	24	7
Mezzanine	D+L	46	Max Drift X	0	15	24	7
Mezzanine	D+L	46	Max Drift Y	0	15	24	7
Mezzanine	DStlS1	46	Max Drift X	0	15	24	7
Mezzanine	DStlS1	46	Max Drift Y	0	15	24	7
Mezzanine	DStlS2	46	Max Drift X	0	15	24	7
Mezzanine	DStlS2	46	Max Drift Y	0	15	24	7
Mezzanine	DStlD1	46	Max Drift X	0	15	24	7
Mezzanine	DStlD1	46	Max Drift Y	0	15	24	7
Mezzanine	DStlD2	46	Max Drift X	0	15	24	7
Mezzanine	DStlD2	46	Max Drift Y	0	15	24	7
Mezzanine	DCon1	46	Max Drift X	0	15	24	7
Mezzanine	DCon1	46	Max Drift Y	0	15	24	7
Mezzanine	DCon2	46	Max Drift X	0	15	24	7

Story	Load Case/Combo	Label	Item	Drift	X m	Y m	Z m
Mezzanine	DCon2	46	Max Drift Y	0	15	24	7

Story Forces

Story	Load Case/Combo	Location	P tonf	VX tonf	VY tonf	T tonf-m	MX tonf-m	MY tonf-m
Roof	Dead	Top	0	0	0	0	0	0
Roof	Dead	Bottom	0	0	0	0	0	0
Roof	Live	Top	0	0	0	0	0	0
Roof	Live	Bottom	0	0	0	0	0	0
Roof	D	Top	0	0	0	0	0	0
Roof	D	Bottom	0	0	0	0	0	0
Roof	D+L	Top	0	0	0	0	0	0
Roof	D+L	Bottom	0	0	0	0	0	0
Roof	DStlS1	Top	0	0	0	0	0	0
Roof	DStlS1	Bottom	0	0	0	0	0	0
Roof	DStlS2	Top	0	0	0	0	0	0
Roof	DStlS2	Bottom	0	0	0	0	0	0
Roof	DStlD1	Top	0	0	0	0	0	0
Roof	DStlD1	Bottom	0	0	0	0	0	0
Roof	DStlD2	Top	0	0	0	0	0	0
Roof	DStlD2	Bottom	0	0	0	0	0	0
Roof	DCon1	Top	0	0	0	0	0	0
Roof	DCon1	Bottom	0	0	0	0	0	0
Roof	DCon2	Top	0	0	0	0	0	0
Roof	DCon2	Bottom	0	0	0	0	0	0
Mezzanine	Dead	Top	0	0	0	0	0	0
Mezzanine	Dead	Bottom	0	0	0	0	0	0
Mezzanine	Live	Top	0	0	0	0	0	0
Mezzanine	Live	Bottom	0	0	0	0	0	0
Mezzanine	D	Top	0	0	0	0	0	0
Mezzanine	D	Bottom	0	0	0	0	0	0
Mezzanine	D+L	Top	0	0	0	0	0	0
Mezzanine	D+L	Bottom	0	0	0	0	0	0
Mezzanine	DStlS1	Top	0	0	0	0	0	0
Mezzanine	DStlS1	Bottom	0	0	0	0	0	0
Mezzanine	DStlS2	Top	0	0	0	0	0	0
Mezzanine	DStlS2	Bottom	0	0	0	0	0	0
Mezzanine	DStlD1	Top	0	0	0	0	0	0
Mezzanine	DStlD1	Bottom	0	0	0	0	0	0
Mezzanine	DStlD2	Top	0	0	0	0	0	0
Mezzanine	DStlD2	Bottom	0	0	0	0	0	0
Mezzanine	DCon1	Top	0	0	0	0	0	0

Story	Load Case/Combo	Location	P tonf	VX tonf	VY tonf	T tonf-m	MX tonf-m	MY tonf-m
Mezzanine	DCon1	Bottom	0	0	0	0	0	0
Mezzanine	DCon2	Top	0	0	0	0	0	0
Mezzanine	DCon2	Bottom	0	0	0	0	0	0

5.3 Point Results

Joint Reactions

Story	Joint Label	Unique Name	Load Case/Combo	FX tonf	FY tonf	FZ tonf	MX tonf-m	MY tonf-m	MZ tonf-m
Roof	1	109	Dead	0	0	20.8	0.00325	28.71	0
Roof	1	109	Live	0	0	7.24	0.001161	9.97	0
Roof	1	109	D	0	0	29.12	0.00455	40.19	0
Roof	1	109	D+L	0	0	36.55	0.01	50.4	0
Roof	1	109	DStlS1	0	0	29.12	0.00455	40.19	0
Roof	1	109	DStlS2	0	0	36.55	0.01	50.4	0
Roof	1	109	DStlD1	0	0	20.8	0.00325	28.71	0
Roof	1	109	DStlD2	0	0	28.04	0.004411	38.68	0
Roof	1	109	DCon1	0	0	29.12	0.00455	40.19	0
Roof	1	109	DCon2	0	0	36.55	0.01	50.4	0
Roof	2	105	Dead	0	0	19.02	0.001438	25.24	0
Roof	2	105	Live	0	0	6.6	0.0005294	8.72	0
Roof	2	105	D	0	0	26.63	0.002013	35.34	0
Roof	2	105	D+L	0	0	33.38	0.002572	44.24	0
Roof	2	105	DStlS1	0	0	26.63	0.002013	35.34	0
Roof	2	105	DStlS2	0	0	33.38	0.002572	44.24	0
Roof	2	105	DStlD1	0	0	19.02	0.001438	25.24	0
Roof	2	105	DStlD2	0	0	25.62	0.001967	33.96	0
Roof	2	105	DCon1	0	0	26.63	0.002013	35.34	0

Story	Joint Label	Unique Name	Load Case/Combo	FX tonf	FY tonf	FZ tonf	MX tonf-m	MY tonf-m	MZ tonf-m
Roof	2	105	DCon2	0	0	33.38	0.00257 2	44.24	0
Roof	5	61	Dead	0	0	25.92	-0.01	-45.56	0
Roof	5	61	Live	0	0	8.88	-	0.00328 2	-15.53
Roof	5	61	D	0	0	36.29	-0.01	-63.78	0
Roof	5	61	D+L	0	0	45.32	-0.02	-79.52	0
Roof	5	61	DStlS1	0	0	36.29	-0.01	-63.78	0
Roof	5	61	DStlS2	0	0	45.32	-0.02	-79.52	0
Roof	5	61	DStlD1	0	0	25.92	-0.01	-45.56	0
Roof	5	61	DStlD2	0	0	34.81	-0.01	-61.09	0
Roof	5	61	DCon1	0	0	36.29	-0.01	-63.78	0
Roof	5	61	DCon2	0	0	45.32	-0.02	-79.52	0
Roof	6	65	Dead	0	0	19.02	0.00143 8	-25.24	0
Roof	6	65	Live	0	0	6.6	0.00052 94	-8.72	0
Roof	6	65	D	0	0	26.63	0.00201 3	-35.34	0
Roof	6	65	D+L	0	0	33.38	0.00257 2	-44.24	0
Roof	6	65	DStlS1	0	0	26.63	0.00201 3	-35.34	0
Roof	6	65	DStlS2	0	0	33.38	0.00257 2	-44.24	0
Roof	6	65	DStlD1	0	0	19.02	0.00143 8	-25.24	0
Roof	6	65	DStlD2	0	0	25.62	0.00196 7	-33.96	0
Roof	6	65	DCon1	0	0	26.63	0.00201 3	-35.34	0
Roof	6	65	DCon2	0	0	33.38	0.00257 2	-44.24	0
Roof	7	69	Dead	0	0	20.8	0.00325	-28.71	0
Roof	7	69	Live	0	0	7.24	0.00116 1	-9.97	0
Roof	7	69	D	0	0	29.12	0.00455	-40.19	0
Roof	7	69	D+L	0	0	36.55	0.01	-50.4	0
Roof	7	69	DStlS1	0	0	29.12	0.00455	-40.19	0
Roof	7	69	DStlS2	0	0	36.55	0.01	-50.4	0

Story	Joint Label	Unique Name	Load Case/Combo	FX tonf	FY tonf	FZ tonf	MX tonf-m	MY tonf-m	MZ tonf-m
Roof	7	69	DStlD1	0	0	20.8	0.00325	-28.71	0
Roof	7	69	DStlD2	0	0	28.04	0.00441 1	-38.68	0
Roof	7	69	DCon1	0	0	29.12	0.00455	-40.19	0
Roof	7	69	DCon2	0	0	36.55	0.01	-50.4	0
Roof	8	73	Dead	0	0	8.82	-3.17	-11.08	0
Roof	8	73	Live	0	0	2.95	-1.13	-3.66	0
Roof	8	73	D	0	0	12.35	-4.44	-15.51	0
Roof	8	73	D+L	0	0	15.31	-5.63	-19.15	0
Roof	8	73	DStlS1	0	0	12.35	-4.44	-15.51	0
Roof	8	73	DStlS2	0	0	15.31	-5.63	-19.15	0
Roof	8	73	DStlD1	0	0	8.82	-3.17	-11.08	0
Roof	8	73	DStlD2	0	0	11.78	-4.31	-14.74	0
Roof	8	73	DCon1	0	0	12.35	-4.44	-15.51	0
Roof	8	73	DCon2	0	0	15.31	-5.63	-19.15	0
Roof	9	57	Dead	0	0	9.06	3.17	-11.43	0
Roof	9	57	Live	0	0	2.94	1.13	-3.63	0
Roof	9	57	D	0	0	12.68	4.44	-16	0
Roof	9	57	D+L	0	0	15.56	5.62	-19.52	0
Roof	9	57	DStlS1	0	0	12.68	4.44	-16	0
Roof	9	57	DStlS2	0	0	15.56	5.62	-19.52	0
Roof	9	57	DStlD1	0	0	9.06	3.17	-11.43	0
Roof	9	57	DStlD2	0	0	11.99	4.31	-15.06	0
Roof	9	57	DCon1	0	0	12.68	4.44	-16	0
Roof	9	57	DCon2	0	0	15.56	5.62	-19.52	0
Roof	10	101	Dead	0	0	25.92	-0.01	45.56	0
Roof	10	101	Live	0	0	8.88	-0.0032	15.53	0
Roof	10	101	D	0	0	36.29	-0.01	63.78	0
Roof	10	101	D+L	0	0	45.32	-0.02	79.52	0
Roof	10	101	DStlS1	0	0	36.29	-0.01	63.78	0
Roof	10	101	DStlS2	0	0	45.32	-0.02	79.52	0
Roof	10	101	DStlD1	0	0	25.92	-0.01	45.56	0
Roof	10	101	DStlD2	0	0	34.81	-0.01	61.09	0
Roof	10	101	DCon1	0	0	36.29	-0.01	63.78	0
Roof	10	101	DCon2	0	0	45.32	-0.02	79.52	0
Roof	11	113	Dead	0	0	8.82	-3.17	11.08	0
Roof	11	113	Live	0	0	2.95	-1.13	3.66	0
Roof	11	113	D	0	0	12.35	-4.44	15.51	0
Roof	11	113	D+L	0	0	15.31	-5.63	19.15	0
Roof	11	113	DStlS1	0	0	12.35	-4.44	15.51	0
Roof	11	113	DStlS2	0	0	15.31	-5.63	19.15	0

Story	Joint Label	Unique Name	Load Case/Combo	FX tonf	FY tonf	FZ tonf	MX tonf-m	MY tonf-m	MZ tonf-m
Roof	11	113	DStlD1	0	0	8.82	-3.17	11.08	0
Roof	11	113	DStlD2	0	0	11.78	-4.31	14.74	0
Roof	11	113	DCon1	0	0	12.35	-4.44	15.51	0
Roof	11	113	DCon2	0	0	15.31	-5.63	19.15	0
Roof	12	97	Dead	0	0	9.06	3.17	11.43	0
Roof	12	97	Live	0	0	2.94	1.13	3.63	0
Roof	12	97	D	0	0	12.68	4.44	16	0
Roof	12	97	D+L	0	0	15.56	5.62	19.52	0
Roof	12	97	DStlS1	0	0	12.68	4.44	16	0
Roof	12	97	DStlS2	0	0	15.56	5.62	19.52	0
Roof	12	97	DStlD1	0	0	9.06	3.17	11.43	0
Roof	12	97	DStlD2	0	0	11.99	4.31	15.06	0
Roof	12	97	DCon1	0	0	12.68	4.44	16	0
Roof	12	97	DCon2	0	0	15.56	5.62	19.52	0
Roof	13	81	Dead	0	0	33.74	1.13	0	0
Roof	13	81	Live	0	0	11.31	0.27	0	0
Roof	13	81	D	0	0	47.23	1.59	0	0
Roof	13	81	D+L	0	0	58.57	1.79	0	0
Roof	13	81	DStlS1	0	0	47.23	1.59	0	0
Roof	13	81	DStlS2	0	0	58.57	1.79	0	0
Roof	13	81	DStlD1	0	0	33.74	1.13	0	0
Roof	13	81	DStlD2	0	0	45.04	1.4	0	0
Roof	13	81	DCon1	0	0	47.23	1.59	0	0
Roof	13	81	DCon2	0	0	58.57	1.79	0	0
Roof	23	12	Dead	0	0	39.2	13.55	-6.28	0
Roof	23	12	Live	0	0	13.38	2.59	-3.09	0
Roof	23	12	D	0	0	54.88	18.97	-8.79	0
Roof	23	12	D+L	0	0	68.44	20.4	-12.48	0
Roof	23	12	DStlS1	0	0	54.88	18.97	-8.79	0
Roof	23	12	DStlS2	0	0	68.44	20.4	-12.48	0
Roof	23	12	DStlD1	0	0	39.2	13.55	-6.28	0
Roof	23	12	DStlD2	0	0	52.58	16.14	-9.37	0
Roof	23	12	DCon1	0	0	54.88	18.97	-8.79	0
Roof	23	12	DCon2	0	0	68.44	20.4	-12.48	0
Roof	28	23	Dead	0	0	9.69	2.39	7.46	0
Roof	28	23	Live	0	0	2.95	0.8	2.41	0
Roof	28	23	D	0	0	13.57	3.34	10.44	0
Roof	28	23	D+L	0	0	16.34	4.15	12.81	0
Roof	28	23	DStlS1	0	0	13.57	3.34	10.44	0
Roof	28	23	DStlS2	0	0	16.34	4.15	12.81	0
Roof	28	23	DStlD1	0	0	9.69	2.39	7.46	0

Story	Joint Label	Unique Name	Load Case/Combo	FX tonf	FY tonf	FZ tonf	MX tonf-m	MY tonf-m	MZ tonf-m
Roof	28	23	DStlD2	0	0	12.64	3.19	9.87	0
Roof	28	23	DCon1	0	0	13.57	3.34	10.44	0
Roof	28	23	DCon2	0	0	16.34	4.15	12.81	0
Roof	29	21	Dead	0	0	9.69	2.39	-7.46	0
Roof	29	21	Live	0	0	2.95	0.8	-2.41	0
Roof	29	21	D	0	0	13.57	3.34	-10.44	0
Roof	29	21	D+L	0	0	16.34	4.15	-12.81	0
Roof	29	21	DStlS1	0	0	13.57	3.34	-10.44	0
Roof	29	21	DStlS2	0	0	16.34	4.15	-12.81	0
Roof	29	21	DStlD1	0	0	9.69	2.39	-7.46	0
Roof	29	21	DStlD2	0	0	12.64	3.19	-9.87	0
Roof	29	21	DCon1	0	0	13.57	3.34	-10.44	0
Roof	29	21	DCon2	0	0	16.34	4.15	-12.81	0
Roof	40	15	Dead	0	0	39.2	13.55	6.28	0
Roof	40	15	Live	0	0	13.38	2.59	3.09	0
Roof	40	15	D	0	0	54.88	18.97	8.79	0
Roof	40	15	D+L	0	0	68.44	20.4	12.48	0
Roof	40	15	DStlS1	0	0	54.88	18.97	8.79	0
Roof	40	15	DStlS2	0	0	68.44	20.4	12.48	0
Roof	40	15	DStlD1	0	0	39.2	13.55	6.28	0
Roof	40	15	DStlD2	0	0	52.58	16.14	9.37	0
Roof	40	15	DCon1	0	0	54.88	18.97	8.79	0
Roof	40	15	DCon2	0	0	68.44	20.4	12.48	0
Roof	4	5	Dead	0	0	43.93	-9.59	-12.71	0
Roof	4	5	Live	0	0	15.08	-1.12	-5.43	0
Roof	4	5	D	0	0	61.5	-13.43	-17.79	0
Roof	4	5	D+L	0	0	76.85	-13.31	-23.93	0
Roof	4	5	DStlS1	0	0	61.5	-13.43	-17.79	0
Roof	4	5	DStlS2	0	0	76.85	-13.31	-23.93	0
Roof	4	5	DStlD1	0	0	43.93	-9.59	-12.71	0
Roof	4	5	DStlD2	0	0	59.02	-10.72	-18.13	0
Roof	4	5	DCon1	0	0	61.5	-13.43	-17.79	0
Roof	4	5	DCon2	0	0	76.85	-13.31	-23.93	0
Roof	18	9	Dead	0	0	43.93	-9.59	12.71	0
Roof	18	9	Live	0	0	15.08	-1.12	5.43	0
Roof	18	9	D	0	0	61.5	-13.43	17.79	0
Roof	18	9	D+L	0	0	76.85	-13.31	23.93	0
Roof	18	9	DStlS1	0	0	61.5	-13.43	17.79	0
Roof	18	9	DStlS2	0	0	76.85	-13.31	23.93	0
Roof	18	9	DStlD1	0	0	43.93	-9.59	12.71	0
Roof	18	9	DStlD2	0	0	59.02	-10.72	18.13	0

Story	Joint Label	Unique Name	Load Case/Combo	FX tonf	FY tonf	FZ tonf	MX tonf-m	MY tonf-m	MZ tonf-m
Roof	18	9	DCon1	0	0	61.5	-13.43	17.79	0
Roof	18	9	DCon2	0	0	76.85	-13.31	23.93	0
Roof	19	33	Dead	0	0	12.36	-6.32	10.72	0
Roof	19	33	Live	0	0	4.08	-2.26	3.67	0
Roof	19	33	D	0	0	17.3	-8.85	15.01	0
Roof	19	33	D+L	0	0	21.36	-11.21	18.73	0
Roof	19	33	DStlS1	0	0	17.3	-8.85	15.01	0
Roof	19	33	DStlS2	0	0	21.36	-11.21	18.73	0
Roof	19	33	DStlD1	0	0	12.36	-6.32	10.72	0
Roof	19	33	DStlD2	0	0	16.44	-8.58	14.38	0
Roof	19	33	DCon1	0	0	17.3	-8.85	15.01	0
Roof	19	33	DCon2	0	0	21.36	-11.21	18.73	0
Roof	46	42	Dead	0	0	12.36	-6.32	-10.72	0
Roof	46	42	Live	0	0	4.08	-2.26	-3.67	0
Roof	46	42	D	0	0	17.3	-8.85	-15.01	0
Roof	46	42	D+L	0	0	21.36	-11.21	-18.73	0
Roof	46	42	DStlS1	0	0	17.3	-8.85	-15.01	0
Roof	46	42	DStlS2	0	0	21.36	-11.21	-18.73	0
Roof	46	42	DStlD1	0	0	12.36	-6.32	-10.72	0
Roof	46	42	DStlD2	0	0	16.44	-8.58	-14.38	0
Roof	46	42	DCon1	0	0	17.3	-8.85	-15.01	0
Roof	46	42	DCon2	0	0	21.36	-11.21	-18.73	0
Mezzanine	1	108	Dead	0	0	3.47	0	0	0
Mezzanine	1	108	Live	0	0	0	0	0	0
Mezzanine	1	108	D	0	0	4.86	0	0	0
Mezzanine	1	108	D+L	0	0	4.16	0	0	0
Mezzanine	1	108	DStlS1	0	0	4.86	0	0	0
Mezzanine	1	108	DStlS2	0	0	4.16	0	0	0
Mezzanine	1	108	DStlD1	0	0	3.47	0	0	0
Mezzanine	1	108	DStlD2	0	0	3.47	0	0	0
Mezzanine	1	108	DCon1	0	0	4.86	0	0	0
Mezzanine	1	108	DCon2	0	0	4.16	0	0	0
Mezzanine	2	104	Dead	0	0	19.82	-0.43	23.3	0
Mezzanine	2	104	Live	0	0	6.75	-0.33	9	0
Mezzanine	2	104	D	0	0	27.75	-0.6	32.62	0
Mezzanine	2	104	D+L	0	0	34.58	-1.04	42.36	0
Mezzanine	2	104	DStlS1	0	0	27.75	-0.6	32.62	0
Mezzanine	2	104	DStlS2	0	0	34.58	-1.04	42.36	0
Mezzanine	2	104	DStlD1	0	0	19.82	-0.43	23.3	0
Mezzanine	2	104	DStlD2	0	0	26.57	-0.76	32.3	0
Mezzanine	2	104	DCon1	0	0	27.75	-0.6	32.62	0

Story	Joint Label	Unique Name	Load Case/Combo	FX tonf	FY tonf	FZ tonf	MX tonf-m	MY tonf-m	MZ tonf-m
Mezzanine	2	104	DCon2	0	0	34.58	-1.04	42.36	0
Mezzanine	5	60	Dead	0	0	26.98	0	-40.8	0
Mezzanine	5	60	Live	0	0	16.29	0	-27.51	0
Mezzanine	5	60	D	0	0	37.77	0	-57.13	0
Mezzanine	5	60	D+L	0	0	58.43	0	-92.99	0
Mezzanine	5	60	DStlS1	0	0	37.77	0	-57.13	0
Mezzanine	5	60	DStlS2	0	0	58.43	0	-92.99	0
Mezzanine	5	60	DStlD1	0	0	26.98	0	-40.8	0
Mezzanine	5	60	DStlD2	0	0	43.26	0	-68.32	0
Mezzanine	5	60	DCon1	0	0	37.77	0	-57.13	0
Mezzanine	5	60	DCon2	0	0	58.43	0	-92.99	0
Mezzanine	6	64	Dead	0	0	19.82	-0.43	-23.3	0
Mezzanine	6	64	Live	0	0	6.75	-0.33	-9	0
Mezzanine	6	64	D	0	0	27.75	-0.6	-32.62	0
Mezzanine	6	64	D+L	0	0	34.58	-1.04	-42.36	0
Mezzanine	6	64	DStlS1	0	0	27.75	-0.6	-32.62	0
Mezzanine	6	64	DStlS2	0	0	34.58	-1.04	-42.36	0
Mezzanine	6	64	DStlD1	0	0	19.82	-0.43	-23.3	0
Mezzanine	6	64	DStlD2	0	0	26.57	-0.76	-32.3	0
Mezzanine	6	64	DCon1	0	0	27.75	-0.6	-32.62	0
Mezzanine	6	64	DCon2	0	0	34.58	-1.04	-42.36	0
Mezzanine	7	68	Dead	0	0	3.47	0	0	0
Mezzanine	7	68	Live	0	0	0	0	0	0
Mezzanine	7	68	D	0	0	4.86	0	0	0
Mezzanine	7	68	D+L	0	0	4.16	0	0	0
Mezzanine	7	68	DStlS1	0	0	4.86	0	0	0
Mezzanine	7	68	DStlS2	0	0	4.16	0	0	0
Mezzanine	7	68	DStlD1	0	0	3.47	0	0	0
Mezzanine	7	68	DStlD2	0	0	3.47	0	0	0
Mezzanine	7	68	DCon1	0	0	4.86	0	0	0
Mezzanine	7	68	DCon2	0	0	4.16	0	0	0
Mezzanine	8	72	Dead	0	0	4.33	-0.25	-3.9	0
Mezzanine	8	72	Live	0	0	0	0	0	0
Mezzanine	8	72	D	0	0	6.07	-0.36	-5.46	0
Mezzanine	8	72	D+L	0	0	5.2	-0.3	-4.68	0
Mezzanine	8	72	DStlS1	0	0	6.07	-0.36	-5.46	0
Mezzanine	8	72	DStlS2	0	0	5.2	-0.3	-4.68	0
Mezzanine	8	72	DStlD1	0	0	4.33	-0.25	-3.9	0
Mezzanine	8	72	DStlD2	0	0	4.33	-0.25	-3.9	0
Mezzanine	8	72	DCon1	0	0	6.07	-0.36	-5.46	0
Mezzanine	8	72	DCon2	0	0	5.2	-0.3	-4.68	0

Story	Joint Label	Unique Name	Load Case/Combo	FX tonf	FY tonf	FZ tonf	MX tonf-m	MY tonf-m	MZ tonf-m
Mezzanine	9	56	Dead	0	0	18.58	0.68	-24.03	0
Mezzanine	9	56	Live	0	0	6.75	0.33	-9	0
Mezzanine	9	56	D	0	0	26.01	0.95	-33.65	0
Mezzanine	9	56	D+L	0	0	33.09	1.34	-43.24	0
Mezzanine	9	56	DStlS1	0	0	26.01	0.95	-33.65	0
Mezzanine	9	56	DStlS2	0	0	33.09	1.34	-43.24	0
Mezzanine	9	56	DStlD1	0	0	18.58	0.68	-24.03	0
Mezzanine	9	56	DStlD2	0	0	25.33	1.01	-33.03	0
Mezzanine	9	56	DCon1	0	0	26.01	0.95	-33.65	0
Mezzanine	9	56	DCon2	0	0	33.09	1.34	-43.24	0
Mezzanine	10	100	Dead	0	0	26.98	0	40.8	0
Mezzanine	10	100	Live	0	0	16.29	0	27.51	0
Mezzanine	10	100	D	0	0	37.77	0	57.13	0
Mezzanine	10	100	D+L	0	0	58.43	0	92.99	0
Mezzanine	10	100	DStlS1	0	0	37.77	0	57.13	0
Mezzanine	10	100	DStlS2	0	0	58.43	0	92.99	0
Mezzanine	10	100	DStlD1	0	0	26.98	0	40.8	0
Mezzanine	10	100	DStlD2	0	0	43.26	0	68.32	0
Mezzanine	10	100	DCon1	0	0	37.77	0	57.13	0
Mezzanine	10	100	DCon2	0	0	58.43	0	92.99	0
Mezzanine	11	112	Dead	0	0	4.34	-0.25	3.9	0
Mezzanine	11	112	Live	0	0	0	0	0	0
Mezzanine	11	112	D	0	0	6.07	-0.36	5.46	0
Mezzanine	11	112	D+L	0	0	5.2	-0.3	4.68	0
Mezzanine	11	112	DStlS1	0	0	6.07	-0.36	5.46	0
Mezzanine	11	112	DStlS2	0	0	5.2	-0.3	4.68	0
Mezzanine	11	112	DStlD1	0	0	4.34	-0.25	3.9	0
Mezzanine	11	112	DStlD2	0	0	4.34	-0.25	3.9	0
Mezzanine	11	112	DCon1	0	0	6.07	-0.36	5.46	0
Mezzanine	11	112	DCon2	0	0	5.2	-0.3	4.68	0
Mezzanine	12	96	Dead	0	0	18.58	0.68	24.03	0
Mezzanine	12	96	Live	0	0	6.75	0.33	9	0
Mezzanine	12	96	D	0	0	26.01	0.95	33.65	0
Mezzanine	12	96	D+L	0	0	33.09	1.34	43.24	0
Mezzanine	12	96	DStlS1	0	0	26.01	0.95	33.65	0
Mezzanine	12	96	DStlS2	0	0	33.09	1.34	43.24	0
Mezzanine	12	96	DStlD1	0	0	18.58	0.68	24.03	0
Mezzanine	12	96	DStlD2	0	0	25.33	1.01	33.03	0
Mezzanine	12	96	DCon1	0	0	26.01	0.95	33.65	0
Mezzanine	12	96	DCon2	0	0	33.09	1.34	43.24	0
Mezzanine	13	80	Dead	0	0	27.27	0	0	0

Story	Joint Label	Unique Name	Load Case/Combo	FX tonf	FY tonf	FZ tonf	MX tonf-m	MY tonf-m	MZ tonf-m
Mezzanine	13	80	Live	0	0	18.03	0	0	0
Mezzanine	13	80	D	0	0	38.18	0	0	0
Mezzanine	13	80	D+L	0	0	61.57	0	0	0
Mezzanine	13	80	DStlS1	0	0	38.18	0	0	0
Mezzanine	13	80	DStlS2	0	0	61.57	0	0	0
Mezzanine	13	80	DStlD1	0	0	27.27	0	0	0
Mezzanine	13	80	DStlD2	0	0	45.3	0	0	0
Mezzanine	13	80	DCon1	0	0	38.18	0	0	0
Mezzanine	13	80	DCon2	0	0	61.57	0	0	0
Mezzanine	23	134	Dead	0	0	22.61	-4.1	-13.94	0
Mezzanine	23	134	Live	0	0	7.6	-2.72	-5.71	0
Mezzanine	23	134	D	0	0	31.65	-5.74	-19.52	0
Mezzanine	23	134	D+L	0	0	39.29	-9.27	-25.87	0
Mezzanine	23	134	DStlS1	0	0	31.65	-5.74	-19.52	0
Mezzanine	23	134	DStlS2	0	0	39.29	-9.27	-25.87	0
Mezzanine	23	134	DStlD1	0	0	22.61	-4.1	-13.94	0
Mezzanine	23	134	DStlD2	0	0	30.21	-6.82	-19.65	0
Mezzanine	23	134	DCon1	0	0	31.65	-5.74	-19.52	0
Mezzanine	23	134	DCon2	0	0	39.29	-9.27	-25.87	0
Mezzanine	28	121	Dead	0	0	23.43	4.1	14.35	0
Mezzanine	28	121	Live	0	0	7.6	2.72	5.71	0
Mezzanine	28	121	D	0	0	32.8	5.74	20.09	0
Mezzanine	28	121	D+L	0	0	40.27	9.27	26.36	0
Mezzanine	28	121	DStlS1	0	0	32.8	5.74	20.09	0
Mezzanine	28	121	DStlS2	0	0	40.27	9.27	26.36	0
Mezzanine	28	121	DStlD1	0	0	23.43	4.1	14.35	0
Mezzanine	28	121	DStlD2	0	0	31.03	6.82	20.06	0
Mezzanine	28	121	DCon1	0	0	32.8	5.74	20.09	0
Mezzanine	28	121	DCon2	0	0	40.27	9.27	26.36	0
Mezzanine	29	122	Dead	0	0	23.43	4.1	-14.35	0
Mezzanine	29	122	Live	0	0	7.6	2.72	-5.71	0
Mezzanine	29	122	D	0	0	32.8	5.74	-20.09	0
Mezzanine	29	122	D+L	0	0	40.27	9.27	-26.36	0
Mezzanine	29	122	DStlS1	0	0	32.8	5.74	-20.09	0
Mezzanine	29	122	DStlS2	0	0	40.27	9.27	-26.36	0
Mezzanine	29	122	DStlD1	0	0	23.43	4.1	-14.35	0
Mezzanine	29	122	DStlD2	0	0	31.03	6.82	-20.06	0
Mezzanine	29	122	DCon1	0	0	32.8	5.74	-20.09	0
Mezzanine	29	122	DCon2	0	0	40.27	9.27	-26.36	0
Mezzanine	40	133	Dead	0	0	22.61	-4.1	13.94	0
Mezzanine	40	133	Live	0	0	7.6	-2.72	5.71	0

Story	Joint Label	Unique Name	Load Case/Combo	FX tonf	FY tonf	FZ tonf	MX tonf-m	MY tonf-m	MZ tonf-m
Mezzanine	40	133	D	0	0	31.65	-5.74	19.52	0
Mezzanine	40	133	D+L	0	0	39.29	-9.27	25.87	0
Mezzanine	40	133	DStlS1	0	0	31.65	-5.74	19.52	0
Mezzanine	40	133	DStlS2	0	0	39.29	-9.27	25.87	0
Mezzanine	40	133	DStlD1	0	0	22.61	-4.1	13.94	0
Mezzanine	40	133	DStlD2	0	0	30.21	-6.82	19.65	0
Mezzanine	40	133	DCon1	0	0	31.65	-5.74	19.52	0
Mezzanine	40	133	DCon2	0	0	39.29	-9.27	25.87	0
Mezzanine	19	48	Dead	0	0	4.34	0	2.17	0
Mezzanine	19	48	Live	0	0	0	0	0	0
Mezzanine	19	48	D	0	0	6.07	0	3.03	0
Mezzanine	19	48	D+L	0	0	5.2	0	2.6	0
Mezzanine	19	48	DStlS1	0	0	6.07	0	3.03	0
Mezzanine	19	48	DStlS2	0	0	5.2	0	2.6	0
Mezzanine	19	48	DStlD1	0	0	4.34	0	2.17	0
Mezzanine	19	48	DStlD2	0	0	4.34	0	2.17	0
Mezzanine	19	48	DCon1	0	0	6.07	0	3.03	0
Mezzanine	19	48	DCon2	0	0	5.2	0	2.6	0
Mezzanine	46	51	Dead	0	0	4.33	0	-2.17	0
Mezzanine	46	51	Live	0	0	0	0	0	0
Mezzanine	46	51	D	0	0	6.07	0	-3.03	0
Mezzanine	46	51	D+L	0	0	5.2	0	-2.6	0
Mezzanine	46	51	DStlS1	0	0	6.07	0	-3.03	0
Mezzanine	46	51	DStlS2	0	0	5.2	0	-2.6	0
Mezzanine	46	51	DStlD1	0	0	4.33	0	-2.17	0
Mezzanine	46	51	DStlD2	0	0	4.33	0	-2.17	0
Mezzanine	46	51	DCon1	0	0	6.07	0	-3.03	0
Mezzanine	46	51	DCon2	0	0	5.2	0	-2.6	0
Base	1	106	Dead	0	0	0	0	0	0
Base	1	106	Live	0	0	0	0	0	0
Base	1	106	D	0	0	0	0	0	0
Base	1	106	D+L	0	0	0	0	0	0
Base	1	106	DStlS1	0	0	0	0	0	0
Base	1	106	DStlS2	0	0	0	0	0	0
Base	1	106	DStlD1	0	0	0	0	0	0
Base	1	106	DStlD2	0	0	0	0	0	0
Base	1	106	DCon1	0	0	0	0	0	0
Base	1	106	DCon2	0	0	0	0	0	0
Base	2	102	Dead	0	0	0	0	0	0
Base	2	102	Live	0	0	0	0	0	0
Base	2	102	D	0	0	0	0	0	0

Story	Joint Label	Unique Name	Load Case/Combo	FX tonf	FY tonf	FZ tonf	MX tonf-m	MY tonf-m	MZ tonf-m
Base	2	102	D+L	0	0	0	0	0	0
Base	2	102	DStlS1	0	0	0	0	0	0
Base	2	102	DStlS2	0	0	0	0	0	0
Base	2	102	DStlD1	0	0	0	0	0	0
Base	2	102	DStlD2	0	0	0	0	0	0
Base	2	102	DCon1	0	0	0	0	0	0
Base	2	102	DCon2	0	0	0	0	0	0
Base	5	58	Dead	0	0	0	0	0	0
Base	5	58	Live	0	0	0	0	0	0
Base	5	58	D	0	0	0	0	0	0
Base	5	58	D+L	0	0	0	0	0	0
Base	5	58	DStlS1	0	0	0	0	0	0
Base	5	58	DStlS2	0	0	0	0	0	0
Base	5	58	DStlD1	0	0	0	0	0	0
Base	5	58	DStlD2	0	0	0	0	0	0
Base	5	58	DCon1	0	0	0	0	0	0
Base	5	58	DCon2	0	0	0	0	0	0
Base	6	62	Dead	0	0	0	0	0	0
Base	6	62	Live	0	0	0	0	0	0
Base	6	62	D	0	0	0	0	0	0
Base	6	62	D+L	0	0	0	0	0	0
Base	6	62	DStlS1	0	0	0	0	0	0
Base	6	62	DStlS2	0	0	0	0	0	0
Base	6	62	DStlD1	0	0	0	0	0	0
Base	6	62	DStlD2	0	0	0	0	0	0
Base	6	62	DCon1	0	0	0	0	0	0
Base	6	62	DCon2	0	0	0	0	0	0
Base	7	66	Dead	0	0	0	0	0	0
Base	7	66	Live	0	0	0	0	0	0
Base	7	66	D	0	0	0	0	0	0
Base	7	66	D+L	0	0	0	0	0	0
Base	7	66	DStlS1	0	0	0	0	0	0
Base	7	66	DStlS2	0	0	0	0	0	0
Base	7	66	DStlD1	0	0	0	0	0	0
Base	7	66	DStlD2	0	0	0	0	0	0
Base	7	66	DCon1	0	0	0	0	0	0
Base	7	66	DCon2	0	0	0	0	0	0
Base	8	70	Dead	0	0	0	0	0	0
Base	8	70	Live	0	0	0	0	0	0
Base	8	70	D	0	0	0	0	0	0
Base	8	70	D+L	0	0	0	0	0	0

Story	Joint Label	Unique Name	Load Case/Combo	FX tonf	FY tonf	FZ tonf	MX tonf-m	MY tonf-m	MZ tonf-m
Base	8	70	DStlS1	0	0	0	0	0	0
Base	8	70	DStlS2	0	0	0	0	0	0
Base	8	70	DStlD1	0	0	0	0	0	0
Base	8	70	DStlD2	0	0	0	0	0	0
Base	8	70	DCon1	0	0	0	0	0	0
Base	8	70	DCon2	0	0	0	0	0	0
Base	9	54	Dead	0	0	0	0	0	0
Base	9	54	Live	0	0	0	0	0	0
Base	9	54	D	0	0	0	0	0	0
Base	9	54	D+L	0	0	0	0	0	0
Base	9	54	DStlS1	0	0	0	0	0	0
Base	9	54	DStlS2	0	0	0	0	0	0
Base	9	54	DStlD1	0	0	0	0	0	0
Base	9	54	DStlD2	0	0	0	0	0	0
Base	9	54	DCon1	0	0	0	0	0	0
Base	9	54	DCon2	0	0	0	0	0	0
Base	10	98	Dead	0	0	0	0	0	0
Base	10	98	Live	0	0	0	0	0	0
Base	10	98	D	0	0	0	0	0	0
Base	10	98	D+L	0	0	0	0	0	0
Base	10	98	DStlS1	0	0	0	0	0	0
Base	10	98	DStlS2	0	0	0	0	0	0
Base	10	98	DStlD1	0	0	0	0	0	0
Base	10	98	DStlD2	0	0	0	0	0	0
Base	10	98	DCon1	0	0	0	0	0	0
Base	10	98	DCon2	0	0	0	0	0	0
Base	11	110	Dead	0	0	0	0	0	0
Base	11	110	Live	0	0	0	0	0	0
Base	11	110	D	0	0	0	0	0	0
Base	11	110	D+L	0	0	0	0	0	0
Base	11	110	DStlS1	0	0	0	0	0	0
Base	11	110	DStlS2	0	0	0	0	0	0
Base	11	110	DStlD1	0	0	0	0	0	0
Base	11	110	DStlD2	0	0	0	0	0	0
Base	11	110	DCon1	0	0	0	0	0	0
Base	11	110	DCon2	0	0	0	0	0	0
Base	12	94	Dead	0	0	0	0	0	0
Base	12	94	Live	0	0	0	0	0	0
Base	12	94	D	0	0	0	0	0	0
Base	12	94	D+L	0	0	0	0	0	0
Base	12	94	DStlS1	0	0	0	0	0	0

Story	Joint Label	Unique Name	Load Case/Combo	FX tonf	FY tonf	FZ tonf	MX tonf-m	MY tonf-m	MZ tonf-m
Base	12	94	DStlS2	0	0	0	0	0	0
Base	12	94	DStlD1	0	0	0	0	0	0
Base	12	94	DStlD2	0	0	0	0	0	0
Base	12	94	DCon1	0	0	0	0	0	0
Base	12	94	DCon2	0	0	0	0	0	0
Base	13	78	Dead	0	0	0	0	0	0
Base	13	78	Live	0	0	0	0	0	0
Base	13	78	D	0	0	0	0	0	0
Base	13	78	D+L	0	0	0	0	0	0
Base	13	78	DStlS1	0	0	0	0	0	0
Base	13	78	DStlS2	0	0	0	0	0	0
Base	13	78	DStlD1	0	0	0	0	0	0
Base	13	78	DStlD2	0	0	0	0	0	0
Base	13	78	DCon1	0	0	0	0	0	0
Base	13	78	DCon2	0	0	0	0	0	0
Base	23	10	Dead	0	0	0	0	0	0
Base	23	10	Live	0	0	0	0	0	0
Base	23	10	D	0	0	0	0	0	0
Base	23	10	D+L	0	0	0	0	0	0
Base	23	10	DStlS1	0	0	0	0	0	0
Base	23	10	DStlS2	0	0	0	0	0	0
Base	23	10	DStlD1	0	0	0	0	0	0
Base	23	10	DStlD2	0	0	0	0	0	0
Base	23	10	DCon1	0	0	0	0	0	0
Base	23	10	DCon2	0	0	0	0	0	0
Base	28	44	Dead	0	0	0	0	0	0
Base	28	44	Live	0	0	0	0	0	0
Base	28	44	D	0	0	0	0	0	0
Base	28	44	D+L	0	0	0	0	0	0
Base	28	44	DStlS1	0	0	0	0	0	0
Base	28	44	DStlS2	0	0	0	0	0	0
Base	28	44	DStlD1	0	0	0	0	0	0
Base	28	44	DStlD2	0	0	0	0	0	0
Base	28	44	DCon1	0	0	0	0	0	0
Base	28	44	DCon2	0	0	0	0	0	0
Base	29	1	Dead	0	0	0	0	0	0
Base	29	1	Live	0	0	0	0	0	0
Base	29	1	D	0	0	0	0	0	0
Base	29	1	D+L	0	0	0	0	0	0
Base	29	1	DStlS1	0	0	0	0	0	0
Base	29	1	DStlS2	0	0	0	0	0	0

Story	Joint Label	Unique Name	Load Case/Combo	FX tonf	FY tonf	FZ tonf	MX tonf-m	MY tonf-m	MZ tonf-m
Base	29	1	DStlD1	0	0	0	0	0	0
Base	29	1	DStlD2	0	0	0	0	0	0
Base	29	1	DCon1	0	0	0	0	0	0
Base	29	1	DCon2	0	0	0	0	0	0
Base	40	13	Dead	0	0	0	0	0	0
Base	40	13	Live	0	0	0	0	0	0
Base	40	13	D	0	0	0	0	0	0
Base	40	13	D+L	0	0	0	0	0	0
Base	40	13	DStlS1	0	0	0	0	0	0
Base	40	13	DStlS2	0	0	0	0	0	0
Base	40	13	DStlD1	0	0	0	0	0	0
Base	40	13	DStlD2	0	0	0	0	0	0
Base	40	13	DCon1	0	0	0	0	0	0
Base	40	13	DCon2	0	0	0	0	0	0
Base	4	2	Dead	0	0	0	0	0	0
Base	4	2	Live	0	0	0	0	0	0
Base	4	2	D	0	0	0	0	0	0
Base	4	2	D+L	0	0	0	0	0	0
Base	4	2	DStlS1	0	0	0	0	0	0
Base	4	2	DStlS2	0	0	0	0	0	0
Base	4	2	DStlD1	0	0	0	0	0	0
Base	4	2	DStlD2	0	0	0	0	0	0
Base	4	2	DCon1	0	0	0	0	0	0
Base	4	2	DCon2	0	0	0	0	0	0
Base	18	6	Dead	0	0	0	0	0	0
Base	18	6	Live	0	0	0	0	0	0
Base	18	6	D	0	0	0	0	0	0
Base	18	6	D+L	0	0	0	0	0	0
Base	18	6	DStlS1	0	0	0	0	0	0
Base	18	6	DStlS2	0	0	0	0	0	0
Base	18	6	DStlD1	0	0	0	0	0	0
Base	18	6	DStlD2	0	0	0	0	0	0
Base	18	6	DCon1	0	0	0	0	0	0
Base	18	6	DCon2	0	0	0	0	0	0
Base	19	46	Dead	0	0	0	0	0	0
Base	19	46	Live	0	0	0	0	0	0
Base	19	46	D	0	0	0	0	0	0
Base	19	46	D+L	0	0	0	0	0	0
Base	19	46	DStlS1	0	0	0	0	0	0
Base	19	46	DStlS2	0	0	0	0	0	0
Base	19	46	DStlD1	0	0	0	0	0	0

Story	Joint Label	Unique Name	Load Case/Combo	FX tonf	FY tonf	FZ tonf	MX tonf-m	MY tonf-m	MZ tonf-m
Base	19	46	DStlD2	0	0	0	0	0	0
Base	19	46	DCon1	0	0	0	0	0	0
Base	19	46	DCon2	0	0	0	0	0	0
Base	46	49	Dead	0	0	0	0	0	0
Base	46	49	Live	0	0	0	0	0	0
Base	46	49	D	0	0	0	0	0	0
Base	46	49	D+L	0	0	0	0	0	0
Base	46	49	DStlS1	0	0	0	0	0	0
Base	46	49	DStlS2	0	0	0	0	0	0
Base	46	49	DStlD1	0	0	0	0	0	0
Base	46	49	DStlD2	0	0	0	0	0	0
Base	46	49	DCon1	0	0	0	0	0	0
Base	46	49	DCon2	0	0	0	0	0	0

5.4 Modal Results

Modal Periods and Frequencies

Case	Mode	Period sec	Frequency cyc/sec	Circular Frequency rad/sec	Eigenvalue rad ² /sec ²
Modal	1	0.165	6.069	38.133	1454.124
Modal	2	0.165	6.069	38.133	1454.124
Modal	3	0.073	13.652	85.7782	7357.8989
Modal	4	0.073	13.652	85.7782	7357.8989
Modal	5	0.058	17.222	108.2112	11709.6541
Modal	6	0.058	17.222	108.2112	11709.6541
Modal	7	0.057	17.665	110.9925	12319.3297
Modal	8	0.057	17.665	110.9925	12319.3297
Modal	9	0.031	32.324	203.0949	41247.5509

Case	Mode	Period sec	Freque ncy cyc/sec	Circula r Freque ncy rad/sec	Eigenva lue rad ² /sec ²
Modal	10	0.026	38.823	243.931 1	59502.3 82
Modal	11	0.026	38.823	243.931 1	59502.3 82
Modal	12	0.025	39.734	249.657 3	62328.7 548

Modal Participating Mass Ratios (Part 1 of 2)

Case	Mode	Period sec	UX	UY	UZ	Sum UX	Sum UY	Sum UZ
Modal	1	0.165	0	0.0812	0	0	0.0812	0
Modal	2	0.165	0	0.0543	0	0	0.1354	0
Modal	3	0.073	0.0003	0	0	0.0003	0.1354	0
Modal	4	0.073	0.1351	0	0	0.1354	0.1354	0
Modal	5	0.058	0	0.1359	0	0.1354	0.2713	0
Modal	6	0.058	0	0.1356	0	0.1354	0.4069	0
Modal	7	0.057	0	0.1911	0	0.1354	0.598	0
Modal	8	0.057	0	0.2079	0	0.1354	0.8059	0
Modal	9	0.031	0	0.0249	0	0.1354	0.8308	0
Modal	10	0.026	0	2.489E- 05	0	0.1354	0.8308	0
Modal	11	0.026	0	0.0002	0	0.1354	0.831	0
Modal	12	0.025	0	0.0001	0	0.1354	0.8311	0

Modal Participating Mass Ratios (Part 2 of 2)

Case	Mode	RX	RY	RZ	Sum RX	Sum RY	Sum RZ
Modal	1	0.014	0	0.0054	0.014	0	0.0054
Modal	2	0.0093	0	0.008	0.0233	0	0.0134
Modal	3	0	0.0001	0.0002	0.0233	0.0001	0.0136
Modal	4	0	0.0232	0.0678	0.0233	0.0233	0.0814
Modal	5	0.0234	0	0.0826	0.0467	0.0233	0.1639
Modal	6	0.0233	0	0.0827	0.07	0.0233	0.2467
Modal	7	0.3523	0	0.1273	0.4223	0.0233	0.374
Modal	8	0.3832	0	0.117	0.8055	0.0233	0.491
Modal	9	0.0458	0	0	0.8513	0.0233	0.491

Case	Mode	RX	RY	RZ	Sum RX	Sum RY	Sum RZ
Modal	10	4.282E-06	0	0.0077	0.8513	0.0233	0.4987
Modal	11	2.891E-05	0	0.0011	0.8513	0.0233	0.4998
Modal	12	0.0002	0	4.579E-05	0.8516	0.0233	0.4999

Modal Load Participation Ratios

Case	Item Type	Item	Static %	Dynamic %
Modal	Acceleration	UX	98.22	13.54
Modal	Acceleration	UY	99.91	83.11
Modal	Acceleration	UZ	0	0

Modal Direction Factors

Case	Mode	Period sec	UX	UY	UZ	RZ
Modal	1	0.165	0	1	0	0
Modal	2	0.165	0	1	0	0
Modal	3	0.073	1	0	0	0
Modal	4	0.073	1	0	0	0
Modal	5	0.058	0	0.782	0	0.218
Modal	6	0.058	0	0.781	0	0.219
Modal	7	0.057	0	0.742	0	0.258
Modal	8	0.057	0	0.773	0	0.227
Modal	9	0.031	0	1	0	0
Modal	10	0.026	0	0	0	1
Modal	11	0.026	0	0.002	0	0.998
Modal	12	0.025	0	0.025	0	0.975

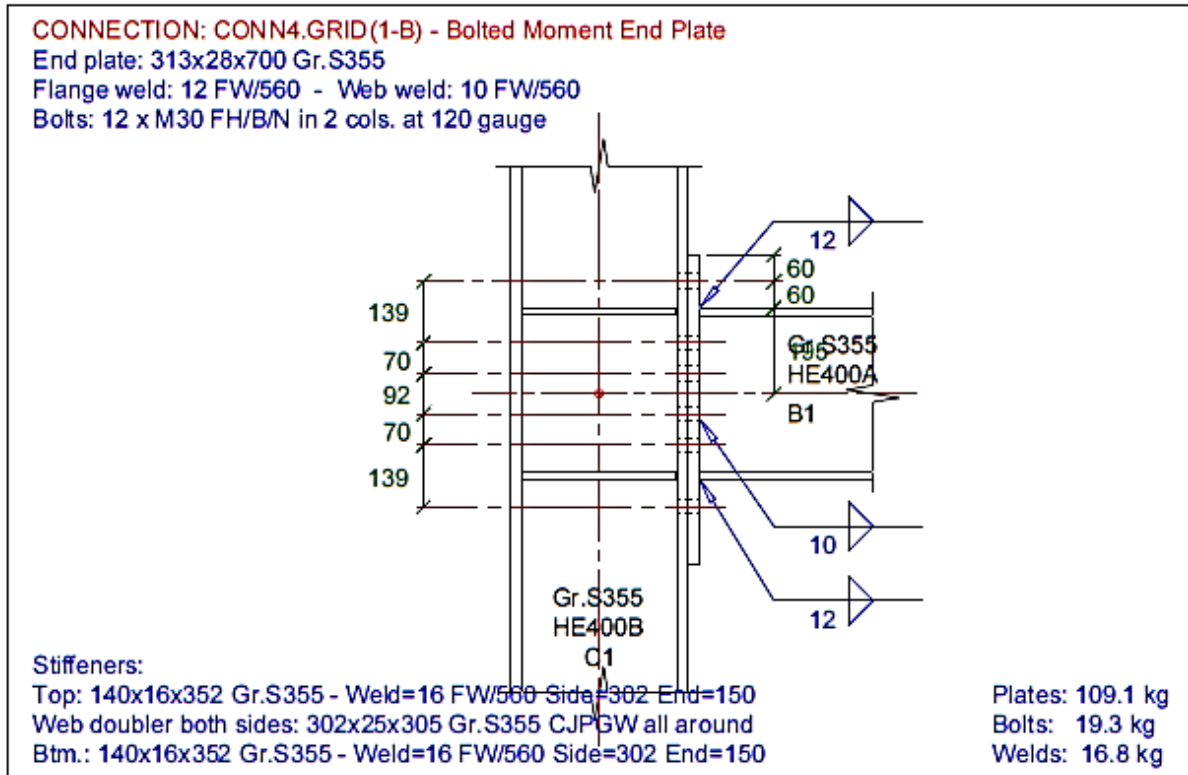

LIMCON V3.63.1.11 (0)

10-DEC-15
16:19:59

Connection: CONN4.GRID(1-B)
 Type: Bolted Moment End Plate
 A - End plate square to beam
 Country: UK
 Units: SI metric
 Design code: ANSI/AISC 360 (ASD)

Beam 1: Mark=B1 Section=HE400A Grade=S355 Angle= 0.00°
 d = 390 mm Root rad. = 27 mm Fyf = 355 N/mm2
 b = 300 mm Area = 1.5900E+04 Fyw = 355 N/mm2
 tf = 19.0 mm Sx = 2311000 Fu = 490 N/mm2
 tw = 11.0 mm Zx = 2562000
 .Section moment strength 544.6 kN.m
 .Section shear strength 608.0 kN
 .Section tension strength 3379.9 kN
 .Section compression strength 3379.9 kN

Note 1
 A360 (G2-1)
 A360-(D2-1)
 A360 E7

Column: Mark=C1 Section=HE400B Grade=S355
 d = 400 mm Root rad. = 27 mm Fyf = 355 N/mm2
 b = 300 mm Area = 1.9800E+04 Fyw = 355 N/mm2
 tf = 24.0 mm Sx = 2884000 Fu = 490 N/mm2
 tw = 13.5 mm Zx = 3232000
 .Section moment strength 687.0 kN.m
 .Section shear strength 765.3 kN
 .Section compression strength 4209.0 kN

Note 1
 A360 (G2-1)
 A360 E7

End plate:
 700x313x28 Gr./Fy/Fu=S355/35/490N/mm2
 Beam to end plate angle 90.00°

End plate welds:
 12 FW/560N/mm2 flanges.
 10 FW/560N/mm2 web.

Bolts:
 6 x M30 FH/B/N top flange, 120 gauge.
 6 x M30 FH/B/N btm. flange, 120 gauge.

Stiffeners: Gr./Fy/Fu=S355/35/490N/mm2 Welds fu=560N/mm2

2/140 x16 top, 16 FW 302 at midpoint and across ends.
2/140 x16 btm., 16 FW 302 at midpoint and across ends.

Web doubler plates:
305x302x25 Gr./Fy/Fu=S355/35/490N/mm2
No. web doubler plates 2
Weld CJPBW/560N/mm2 all around.

BILL OF MATERIALS

Plates:
1 no. - 700x313x28 Grade=S355 48.2 kg
4 no. - 352x140x16 Grade=S355 24.8 kg
2 no. - 305x302x25 Grade=S355 36.2 kg
Total mass of plates 109.1 kg
Bolts:
12 no. - M30 FH/B/N x 110 long 19.3 kg
Welds:
1200 mm - FW 12 fu=560N/mm2 0.7 kg
704 mm - FW 10 fu=560N/mm2 0.3 kg
4816 mm - FW 16 fu=560N/mm2 4.8 kg
1220 mm - CJPBW 25x25x85% fu=560N/mm2 5.1 kg
1208 mm - CJPBW 25x25x100% fu=560N/mm2 5.9 kg
Total mass of welds 16.8 kg

MINIMUM ACTION CHECK

(Minima are based on section capacity, not member capacity.)

Specified minimum design actions:
Bending 50% of Ms/Q (544.6) = 272.3 kN.m
Shear 0% of Vs/Q (609.2) = 0.0 kN
40.0 kN
Tension 0% of Ns/Q (3379.9) = 0.0 kN
Compression 0% of Nc/Q (3379.9) = 0.0 kN

NOTE: Input design actions are not automatically increased if they are less than the specified minimum actions. Minimum actions may be set in any load case. This check warns if any design action is less than the specified minimum for all load cases.

INPUT DESIGN ACTIONS

Beam 1: Moment, M 386.6 kN.m
Shear, V 235.0 kN
Axial, P 0.0 kN
Column: Shear, Vc 0.0 kN
Compression, Fc 0.0 kN

SECTION ANALYSIS RESULT

Simplified analysis:
Beam 1... Pft = 1042.1t Pfc = 1042.1c
Pwt = 0.0 Pwc = 0.0
Mw = 0.00
Vw = 235.0
Elastic analysis:
Beam 1... Pft = 949.7t Pfc = 949.7c
Pwt = 0.0 Pwc = 0.0
Mw = 34.3
Vw = 235.0
Plastic analysis:
Beam 1... Pft = 907.8t Pfc = 907.8c
Pwt = 0.0 Pwc = 0.0
Mw = 49.8
Vw = 235.0

NOTE: Simplified analysis results used.

BOLT ARRANGEMENT

6-Bolt 2/4 Extended End Plate
Connection checked for tension at top flange.

Using AISC/ASI model...

- Ref. 18: Steel Design Guide 16 (SDG16)
Flush and Extended Multiple Row Moment End Plate Connections
T.M. Murray & W.L. Shoemaker - AISC - 2002
- Ref. 19: Steel Design Guide 4 (SDG4)
Extended End Plate Moment Connections - Seismic and Wind Applications
T.M. Murray & E.A. Sumner - AISC - 2004
- Ref. 43: Design Guide 12 - Bolted End Plate to Column Moment Connections (DG12)
T.J. Hogan & N. van der Kreek - ASI - 2009

GEOMETRY CHECKS

CHECK 1 - Detailing Requirements:
Bolt UTS 1000 ≥ 800 Yes

End plate width, b_1	313	\geq	313	Yes
	313	\leq	325	Yes

NOTE: Clearances should be checked in virtual reality view.

ASD STRENGTH CHECKS

Section	Strength ratio Required strength ASD strength	Reference
Section Bending/Axial:		
Flange tension yield strength	1211.7 \geq Pft = 907.8 1.33	Pass Manual p.55
Flange tension rupture strength	1396.5 \geq Pft = 907.8 1.54	Pass
Flange compression strength	1211.7 \geq Pft = 907.8 1.33	Pass
CHECK 2 - Flange Welds:		
Flange width	300 mm	
Total fillet weld length	589 mm	SDG4 p.38
For 12 EW/560N/mm2 both sides...		
NOTE: Using 50% directional strength increase.		
Fillet weld strength	2.138 kN/mm	A360 (J2-5)
Flange fillet weld tension strength	1259.5 \geq Pft = 1042.1 1.21	Pass
Flange fillet weld compression strength	1259.5 \geq Pfc = 1042.1 1.21	Pass
CHECK 3 - Web Welds:		
Web shear force	235.0 kN	
Web axial force	0.0 kN	
Web bending moment	0.00 kN.m	
Length of web weld	352 mm	
NOTE: This check uses method from AISC SDG 16 (Ref. 18).		
Length for shear resistance	176 mm	
For 10 EW/560N/mm2 both sides...		
Web fillet weld shear strength (2 sides)	418.2 \geq V = 235.0 1.78	Pass
End plate design moment, M_{eq}	386.6 kN.m	
Section moment strength	544.6 kN.m	
Beam moment utilization ratio	71%	
Beam web axial strength	2.338 kN/mm	
* Web weld design force	1.660 kN/mm	
NOTE: Using 50% directional strength increase.		
Fillet weld strength	1.782 kN/mm	A360 (J2-5)
Web fillet weld axial strength (2 sides)	3.564 \geq pw = 1.660 2.15	Pass
CHECK 4 - Bolts at Tension Flange:		
Single bolt tension strength	275.7 kN	A360-T:J3.2
No. bolts effective at flange	6	
Sum of bolt lever arms	974 mm	
End plate design moment, M_{eq}	386.6 kN.m	
Tension bolt moment strength, M_{np}/Q	536.8 \geq M_{eq} = 386.6 1.39	Pass
CHECK 5 - Bolts in Shear:		
Total shear resisted by bolts	235.0 kN	
Single bolt shear strength	161.5 kN	A360-T:J3.2
No. bolts effective in shear	6	
Bolt shear strength, R_n/Q	969.2 \geq V_b = 235.0 4.12	Pass SDG4 (3.17)
End plate bolt bearing strength, R_n/Q	2963.5 \geq V_b = 235.0 12.6	Pass SDG4 (3.18)
CHECK 6 - End Plate in Bending:		
End plate design moment, M_{eq}	386.6 kN.m	
Yield line parameter, Y_p	3298 mm	
End plate yield strength, M_{pl}/Q	549.6 \geq M_{eq} = 386.6 1.42	Pass
Bolt moment strength, M_{bt}/Q	536.8 kN.m	
* No prying strength, M_{min}	595.8 kN.m	
* End plate no prying thickness	29 mm	
Is plate strong enough for no prying?	826.0 \geq 893.7	No SDG4 (3.10)
* Bolt prying does occur.		
Single bolt tension strength	275.7 kN	A360-T:J3.2
Specified minimum tension	370.0 kN	
Bolt max. prying force, $Q_{max,i}$	99.4 kN	SDG16 p.31
Bolt max. prying force, $Q_{max,o}$	122.4 kN	SDG16 p.31
Bolt rupture strength (prying)	410.9 \geq M_{eq} = 386.6 1.06	Pass
Prying factor	0.42	Informative
Bolt efficiency	77%	Informative
CHECK 7 - End Plate in Shear:		
Horiz. shear	347.4 kN	
Horiz. shear yield strength, R_n/Q	1244.5 \geq V_h = 347.4 3.58	Pass SDG4 (3.12)
Horiz. shear rupture strength, R_n/Q	1000.2 \geq V_h = 347.4 2.88	Pass SDG4 (3.13)
CHECK 8 - End Plate Stiffener:		
No stiffener.		
CHECK 9 - End Plate Stiffener Welds:		

No stiffener.

COLUMN-SIDE CHECKS...

Ref. 19: Steel Design Guide 4 (SDG4)
Extended End Plate Moment Connections - Seismic and Wind Applications
T.M. Murray & E.A. Sumner - AISC - 2004

CHECK 10/16 - Unstiffened Column Flange Bending at Beam Tension Flange:

NOTE: This capacity is required for checking stiffeners.
Using method from AISC SDG 4 (Ref.19)...

End plate design moment, Meq	386.6 kN.m				
Yield line parameter, Yc	3557 mm				
Col. flange no prying thickness	28 mm				SDG4 (3.20)
Column flange strength	435.6 kN.m				
Equivalent flange force, Rn/Q	1174.0 kN				SDG4 (3.22)
End plate design moment, Meq	386.6 kN.m				
No prying strength, Mmin	594.6 kN.m				
Unstiffened col. flange strength, Mcf/Q	435.6	≥	Meq = 386.6	1.13	Pass Informative

» Tension flange stiffeners may not be required.

CHECK 11 - Unstiffened Column Web Yielding at Beam Tension Flange:

NOTE: This capacity is required for checking stiffeners.
Unstiffened col. web yield strength, Rn/Q 1294.0 ≥ Pft = 1042.1 1.24 Pass Informative
» Tension flange stiffeners may not be required.

CHECK 12 - Unstiffened Column Web Yielding at Beam Compression Flange:

NOTE: This capacity is required for checking stiffeners.
Unstiffened col. web yield strength, Rn/Q 1294.0 ≥ Pfc = 1042.1 1.24 Pass Informative
» Compression flange stiffeners may not be required.

CHECK 13 - Unstiffened Column Web Crippling at Beam Compression Flange:

NOTE: This check not required with compression flange stiffeners.
Column web crippling strength, Rn/Q 1075.4 ≥ Pfc = 1042.1 1.03 Pass Informative
» Compression flange stiffeners may not be required.

CHECK 14 - Unstiffened Column Web Buckling at Beam Compression Flange:

NOTE: This check not required with compression flange stiffeners.
Column web buckling strength, Rn/Q 999.8 ≥ Pfc = 1042.1 0.96 Fail Informative

CHECK 15/21 - Unstiffened Column Web Panel in Shear:

Web doubler thickness	25	≥	14		Yes
Total web doubler thickness	50 mm				
Column nominal axial capacity, Py	14129 kN				Note 4
Ratio Pu/Py	0.00				
Column web panel shear	1042.1 kN				
Column web panel shear strength, Rv/Q	3239.6	≥	Vp = 1042.1	3.11	Pass SDG13 (2.2-1)

CHECK 22 - Transverse Stiffeners at Beam Tension Flange:

Stiffener width	140	≥	143		Yes
	140	≤	143		Yes
Stiffener effective width	125 mm				
Stiffener thickness	16.0	≥	9.5		Yes
Column flange strength, Rft/Q	1174.0 kN				
Column web yield strength, Rwt/Q	1291.4 kN				
» Unstiffened column strength	1174.0 kN				
Flange tension	1042.1 kN				

» Check of stiffeners not required.

CHECK 22A - Stiffened Column Flange Bending at Beam Tension Flange:

Using method from AISC SDG 4 (Ref.19)...

Yield line parameter, Ycs	5113 mm				
Col. flange no prying thickness	23 mm				SDG4 (3.20)
Column flange strength	626.1 kN.m				
End plate design moment, Meq	386.6 kN.m				
Stiffened col. flange strength, Mcts/Q	626.1	≥	Meq = 386.6	1.62	Pass
No prying strength, Mmin	594.6 kN.m				
Is col. flange strong enough for no prying?	941.0	≥	893.7		Yes

» Bolt prying may not occur.

CHECK 23 - Transverse Stiffeners at Beam Compression Flange:

Stiffener width	140	≥	143		Yes
	140	≤	143		Yes
Stiffener thickness	16.0	≥	9.5		Yes
Stiffener side weld	302	≥	302		Yes
Column web yield strength	1291.4 kN				
Column web crippling strength	1073.3 kN				
Column web buckling strength	999.8 kN				
» Unstiffened column strength	999.8 kN				
Flange compression	1042.1 kN				
» Stiffener design compression	42.3 kN				

Stiffener section yield...

Stiffener yield strength, R_{fcs}/Ω	850.3	≥	Pcs	=	42.3	20.1	Pass
Stiffener effective width	125 mm						
Stiffener section strong axis buckling...							
Stiffener buckling strength, R_{fcb}/Ω	895.5	≥	Pcs	=	42.3	21.2	Pass
Side welds...							
Total side weld length	1208 mm						
Stiffener side weld strength, R_{ftw}/Ω	2296.0	≥	Pcs	=	42.3	54.3	Pass

CHECK 24 - Diagonal Shear Stiffeners:
No diagonal shear stiffeners.

NOTES:

1. Flexural yield capacity ignoring section slenderness.
4. Compression yield capacity of section ignoring slenderness.

CRITICAL LIMIT STATE . . . Bolt rupture strength (prying)
UTILIZATION RATIO 94%
STRENGTH RATIO 1.063 Pass

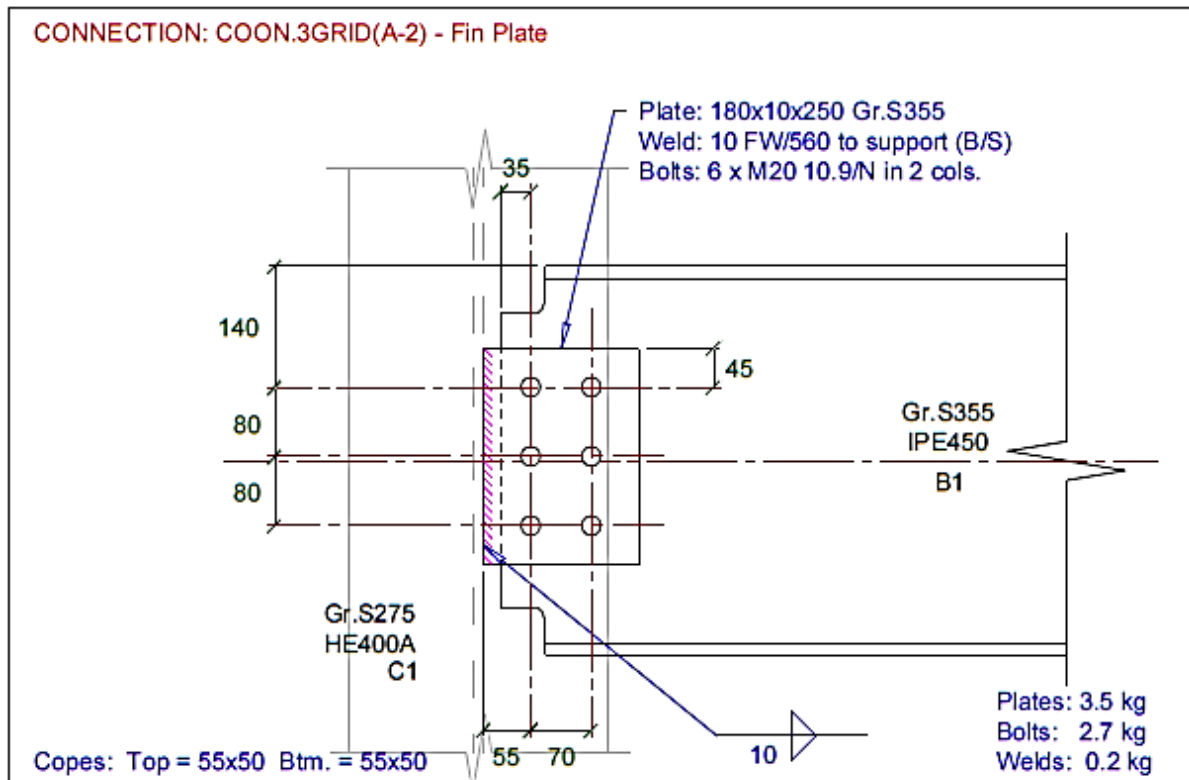

Geometry Check:

*** WARNING -- Cleat top edge distance > 2 x dia.
1 warning.

LIMCON V3.63.1.11 (0)

10-DEC-15
16:16:34

Connection: COON.3GRID(A-2)
Type: Fin Plate
Country: UK
Units: SI metric
Design code: ANSI/AISC 360 (ASD)

Beam: Mark=B1 Section=IPE450 Grade=S355 Span=9.0 m
d = 450 mm Root rad. = 21 mm Fyf = 355 N/mm2
b = 190 mm Area = 9880 Fyw = 355 N/mm2
tf = 14.6 mm Sx = 1500000 Fu = 490 N/mm2
tw = 9.4 mm Zx = 1702000

.Section shear strength 599.5 kN
.Section tension strength 2100.2 kN
.Section compression strength 2027.8 kN
Top cope depth 55 mm
Top cope length 50 mm
Bottom cope depth 55 mm
Bottom cope length 50 mm

A360 (G2-1)
A360-(D2-1)
A360 E7

Plate:
250x180x10 Gr./Fy/Fu=S355/35/490N/mm2

Bolts:
6 x M20 10.9/N in 2 columns.
Bolt pitch, sp 80 mm
Support to 1st bolt column, sgl 55 mm
Bolt gauge, sq2 70 mm

Weld:
10 FW/560N/mm2 to support.

Support: Mark=C1 Section=HE400A Grade=S275
d = 390 mm Root rad. = 27 mm Fyf = 275 N/mm2
b = 300 mm Area = 1.5900E+04 Fyw = 275 N/mm2
tf = 19.0 mm Sx = 2311000 Fu = 430 N/mm2

CHECK 5 - Beam Shear:							
Double-coped web shear yield strength . . .	453.8	≥ V	=	87.3	5.20	Pass	A360 (J4-3)
Double-coped web shear rupture strength . .	370.3	≥ V	=	87.3	4.24	Pass	A360 (J4-4)
CHECK 6 - Beam Web Block Shear:							
Coped web block shear strength	324.7	≥ V	=	87.3	3.72	Pass	A360-(J4-5)
CHECK 7 - Coped Beam Bending:							
Coped section moment strength	57.7	kN.m					
Coped web moment strength	825.0	≥ V	=	87.3	9.45	Pass	
Estimated max. cope length . . .	450	mm					
CHECK 8 - Beam Rotation:							
Rotation for UDL (rad.)	0.009						
Rotation for contact (rad.)	0.087						
Contact rotation strength	869.3	≥ V	=	87.3	9.96	Pass	
Max. bolt shear deformation	0.8	mm					
Max. recommended deformation	4.8	mm					
Strength at bolt deformation limit	545.2	≥ V	=	87.3	6.25	Pass	Informative
CHECK 9 - Coped Beam Buckling:							
NOTE: Coped beam must be restrained against lateral torsional buckling.							
Buckling check to AISC SCM 13th p.9-7 (Cheng, Yura, Johnston)...							
Critical stress, F_{cr}	5229	N/mm ²					
Critical stress, $F_{cr} \leq F_y$	355	N/mm ²					
Coped web elastic modulus	181106	mm ³					
Double-coped web buckling strength	550.0	≥ V	=	87.3	6.30	Pass	
Estimated max. cope length	450	mm					
CHECK 10 - Support Member:							
Depth of shear surface	250	mm					
Column web local shear strength	605.0	≥ V	=	87.3	6.93	Pass	P212 p.167
Max. plate thickness (punching)	13.3	mm					
Plate thickness	10.0		≤	13.3		Yes	
Informative checks for double-sided connection...							
Local shear strength for beam both sides .	605.0	≥ 2V	=	174.6	3.47	Pass	
NOTES:							
1. Flexural yield capacity ignoring section slenderness.							
CRITICAL LIMIT STATE	Bolt group shear strength						
UTILIZATION RATIO	42%						
STRENGTH RATIO	2.409 Pass						

CONNECTION: conn2.grid(3-B) - Bolted Moment End Plate
 End plate: 313x25x700 Gr.S355
 Flange weld: 16 FW/560 - Web weld: 8 FW/560
 Bolts: 12 x M24 FH/B/N in 2 cols. at 120 gauge

Stiffeners:
 Top: 140x16x352 Gr.S355 - Weld=12 FW/560 Side=302 End=150
 Web doubler both sides: 316x16x371 Gr.S355 CJP/GW all around
 Btm.: 140x16x352 Gr.S355 - Weld=12 FW/560 Side=302 End=150

Plates: 97.2 kg
 Bolts: 10.0 kg
 Welds: 9.2 kg

LIMCON V3.63.1.11 (0)

10-DEC-15
16:19:15

Connection: conn2.grid(3-B)
 Type: Bolted Moment End Plate
 A - End plate square to beam
 Country: UK
 Units: SI metric
 Design code: ANSI/AISC 360 (ASD)

Beam 1: Mark=B1 Section=HE450A Grade=S355 Angle= 0.00°
 d = 440 mm Root rad. = 27 mm Fyf = 355 N/mm2
 b = 300 mm Area = 1.7800E+04 Fyw = 355 N/mm2
 tf = 21.0 mm Sx = 2896000 Fu = 490 N/mm2
 tw = 11.5 mm Zx = 3216000
 .Section moment strength 683.6 kN.m
 .Section shear strength 717.1 kN
 .Section tension strength 3783.8 kN
 .Section compression strength . . 3783.8 kN

Note 1
 A360 (G2-1)
 A360-(D2-1)
 A360 E7

Column: Mark=C1 Section=HE400B Grade=S355
 d = 400 mm Root rad. = 27 mm Fyf = 355 N/mm2
 b = 300 mm Area = 1.9800E+04 Fyw = 355 N/mm2
 tf = 24.0 mm Sx = 2884000 Fu = 490 N/mm2
 tw = 13.5 mm Zx = 3232000
 .Section moment strength 687.0 kN.m
 .Section shear strength 765.3 kN
 .Section compression strength . . 4209.0 kN

Note 1
 A360 (G2-1)
 A360 E7

End plate:
 700x313x25 Gr./Fy/Fu=S355/35/490N/mm2
 Beam to end plate angle 90.00°

End plate welds:
 16 FW/560N/mm2 flanges.
 8 FW/560N/mm2 web.

Bolts:
 6 x M24 FH/B/N top flange, 120 gauge.
 6 x M24 FH/B/N btm. flange, 120 gauge.

Stiffeners: Gr./Fy/Fu=S355/35/490N/mm2 Welds fu=560N/mm2

2/140 x16 top, 12 FW 302 at midpoint and across ends.
2/140 x16 btm., 12 FW 302 at midpoint and across ends.

Web doubler plates:
371x316x16 Gr./Fy/Fu=S355/35/490N/mm2
No. web doubler plates 2
Weld CJPGW/560N/mm2 all around.

BILL OF MATERIALS

Plates:
1 no. - 700x313x25 Grade=S355 43.0 kg
4 no. - 352x140x16 Grade=S355 24.8 kg
2 no. - 371x316x16 Grade=S355 29.4 kg
Total mass of plates 97.2 kg
Bolts:
12 no. - M24 FH/B/N x 90 long 10.0 kg
Welds:
1200 mm - FW 16 fu=560N/mm2 1.2 kg
796 mm - FW 8 fu=560N/mm2 0.2 kg
4816 mm - FW 12 fu=560N/mm2 2.7 kg
1484 mm - CJPGW 16x16x85% fu=560N/mm2 2.5 kg
1264 mm - CJPGW 16x16x100% fu=560N/mm2 2.5 kg
Total mass of welds 9.2 kg

MINIMUM ACTION CHECK

{Minima are based on section capacity, not member capacity.}

Specified minimum design actions:
Bending 50% of Ms/Q { 683.6 } = 341.8 kN.m
Shear 0% of Vs/Q { 718.5 } = 0.0 kN
40.0 kN
Tension 0% of Ns/Q { 3783.8 } = 0.0 kN
Compression 0% of Nc/Q { 3783.8 } = 0.0 kN

NOTE: Input design actions are not automatically increased if they are less than the specified minimum actions. Minimum actions may be set in any load case. This check warns if any design action is less than the specified minimum for all load cases.

INPUT DESIGN ACTIONS

Beam 1: Moment, M 387.5 kN.m
Shear, V 229.4 kN
Axial, P 0.0 kN
Column: Shear, Vc 0.0 kN
Compression, Pc 0.0 kN

SECTION ANALYSIS RESULT

Simplified analysis:
Beam 1... Pft = 924.8t Pfc = 924.8c
Pwt = 0.0 Pwc = 0.0
Mw = 0.00
Vw = 229.4
Elastic analysis:
Beam 1... Pft = 837.1t Pfc = 837.1c
Pwt = 0.0 Pwc = 0.0
Mw = 36.7
Vw = 229.4
Plastic analysis:
Beam 1... Pft = 803.3t Pfc = 803.3c
Pwt = 0.0 Pwc = 0.0
Mw = 50.9
Vw = 229.4

NOTE: Simplified analysis results used.

BOLT ARRANGEMENT

6-Bolt 2/4 Extended End Plate
Connection checked for tension at top flange.

Using AISC/ASI model...

- Ref. 18: Steel Design Guide 16 (SDG16)
Flush and Extended Multiple Row Moment End Plate Connections
T.M. Murray & W.L. Shoemaker - AISC - 2002
- Ref. 19: Steel Design Guide 4 (SDG4)
Extended End Plate Moment Connections - Seismic and Wind Applications
T.M. Murray & E.A. Sumner - AISC - 2004
- Ref. 43: Design Guide 12 - Bolted End Plate to Column Moment Connections (DG12)
T.J. Hogan & N. van der Kreek - ASI - 2009

GEOMETRY CHECKS

CHECK 1 - Detailing Requirements:
Bolt UTS 1000 ≥ 800 Yes

CHECK 10/16 - Unstiffened Column Flange Bending at Beam Tension Flange:
 NOTE: This capacity is required for checking stiffeners.
 Using method from AISC SDG 4 (Ref.19)...

End plate design moment, Meq . . .	387.5 kN.m			
Yield line parameter, Yc	4060 mm			
Col. flange no prying thickness . . .	23 mm			SDG4 (3.20)
Column flange strength	497.1 kN.m			
Equivalent flange force, Rn/Q . . .	1186.4 kN			SDG4 (3.22)
End plate design moment, Meq . . .	387.5 kN.m			
No prying strength, Mmin	437.2 kN.m			
Unstiffened col. flange strength, Mcf/Q . .	497.1	≥	Meq = 387.5	1.28 Pass Informative

» Tension flange stiffeners may not be required.

CHECK 11 - Unstiffened Column Web Yielding at Beam Tension Flange:
 NOTE: This capacity is required for checking stiffeners.

Unstiffened col. web yield strength, Rn/Q .	1306.8	≥	Pft = 924.8	1.41 Pass Informative
---	--------	---	-------------	-----------------------

» Tension flange stiffeners may not be required.

CHECK 12 - Unstiffened Column Web Yielding at Beam Compression Flange:
 NOTE: This capacity is required for checking stiffeners.

Unstiffened col. web yield strength, Rn/Q .	1306.8	≥	Pfc = 924.8	1.41 Pass Informative
---	--------	---	-------------	-----------------------

» Compression flange stiffeners may not be required.

CHECK 13 - Unstiffened Column Web Crippling at Beam Compression Flange:
 NOTE: This check not required with compression flange stiffeners.

Column web crippling strength, Rn/Q	1085.8	≥	Pfc = 924.8	1.17 Pass Informative
---	--------	---	-------------	-----------------------

» Compression flange stiffeners may not be required.

CHECK 14 - Unstiffened Column Web Buckling at Beam Compression Flange:
 NOTE: This check not required with compression flange stiffeners.

Column web buckling strength, Rn/Q	999.8	≥	Pfc = 924.8	1.08 Pass Informative
--	-------	---	-------------	-----------------------

» Compression flange stiffeners may not be required.

CHECK 15/21 - Unstiffened Column Web Panel in Shear:

Web doubler thickness	16	≥	14	Yes
Total web doubler thickness	32 mm			
Column nominal axial capacity, Py	11573 kN			Note 4
Ratio Pu/Py	0.00			
Column web panel shear	924.8 kN			
Column web panel shear strength, Rv/Q . . .	2321.3	≥	Vp = 924.8	2.51 Pass SDG13 (2.2-1)

CHECK 22 - Transverse Stiffeners at Beam Tension Flange:

Stiffener width	140	≥	143	Yes
	140	≤	143	Yes
Stiffener effective width	125 mm			
Stiffener thickness	16.0	≥	10.5	Yes
Column flange strength, Rft/Q . . .	1186.4 kN			
Column web yield strength, Rwt/Q	1304.1 kN			
» Unstiffened column strength . . .	1186.4 kN			
Flange tension	924.8 kN			

» Check of stiffeners not required.

CHECK 22A - Stiffened Column Flange Bending at Beam Tension Flange:
 Using method from AISC SDG 4 (Ref.19)...

Yield line parameter, Ycs	6073 mm			
Col. flange no prying thickness	18 mm			SDG4 (3.20)
Column flange strength	743.6 kN.m			
End plate design moment, Meq . . .	387.5 kN.m			
Stiffened col. flange strength, Mcts/Q . . .	743.6	≥	Meq = 387.5	1.92 Pass
No prying strength, Mmin	437.2 kN.m			
Is col. flange strong enough for no prying?	1117.6	≥	657.2	Yes

» Bolt prying may not occur.

CHECK 23 - Transverse Stiffeners at Beam Compression Flange:

Stiffener width	140	≥	143	Yes
	140	≤	143	Yes
Stiffener thickness	16.0	≥	10.5	Yes
Stiffener side weld	302	≥	302	Yes
Column web yield strength	1304.1 kN			
Column web crippling strength . . .	1083.6 kN			
Column web buckling strength . . .	999.8 kN			
» Unstiffened column strength . . .	999.8 kN			
Flange compression	924.8 kN			

» Check of stiffeners not required.

CHECK 24 - Diagonal Shear Stiffeners:
 No diagonal shear stiffeners.

NOTES:
 1. Flexural yield capacity ignoring section slenderness.

4. Compression yield capacity of section ignoring slenderness.

CRITICAL LIMIT STATE . . . Bolt rupture strength (no prying)
UTILIZATION RATIO 98%
STRENGTH RATIO 1.019 Pass

References

Lecture Notes:

Design of Steel Structures, Dr. Andi Asiz, spring 2015

Reinforced Concrete Design, Eng. Danish Ahmed, spring 2015

Intro. To Geotechnical Engineering, Dr. Alaa salman, fall 2015

Books/Articles:

Wang, C., & Salmon, C. (1985). *Reinforced concrete design* (4th ed.). New York: Harper & Row.

Building code requirements for structural concrete (ACI 318-08) and commentary. (2008). Farmington Hills, Mich.: American Concrete Institute.

كود البناء السعودي. (n.d.). Retrieved December 26, 2015, from <http://www.sbc.gov.sa/>

Steel construction manual (13th ed.). (2005). Chicago, Ill.: American Institute of Steel Construction.

Steel construction, a manual for architects, engineers and fabricators of buildings and other steel structures. (5th ed.). (1947). New York, N.Y.: American Institute of Steel Construction.